



LBCA - **12** - **S**

Linear Ball Bushing

- LBCA** - Precision ball bushing (closed - all steel)
- LBOA** - Precision ball bushing (open - all steel)

Nominal Diameter

- 4** - 0.250 inch diameter
- 6** - 0.375 inch diameter
- 8** - 0.500 inch diameter
- 10** - 0.625 inch diameter
- 12** - 0.750 inch diameter
- 16** - 1.000 inch diameter
- 20** - 1.250 inch diameter
- 24** - 1.500 inch diameter
- 32** - 2.000 inch diameter

Bushing Seals

- No seals
- S** - Seals at both ends

Specifications: LBCA & LBOA Linear Precision Ball Bushings

Operating Temperature	0° F to +600° F (without seals)		0° F to +185° F (with seals)		
Maximum Speed	10 ft/second				
Bushing Seals (optional)	Internal Wiper Seals on both ends, Plastic Bearing Retainer				
Matching Shaft	Class S (SS series), hardened & ground shafting (see pages 44 - 45)				
Housing Tolerances C = clearance	LBCA (closed style)			LBOA (open style)	
	Nominal Shaft Diameter (inches)	Recommended Housing Bore		Nominal Shaft Diameter (inches)	Recommended Housing Bore before adjustment (inches)
		Normal Fit (inches)	Press Fit (inches)		
	0.250	.5005 / .5000	.4995 / .4990		
	0.375	.6255 / .6250	.6245 / .6240		
	0.500	.8755 / .8750	.8745 / .8740	0.500	.8760 / .8740
	0.625	1.1255 / 1.1250	1.1245 / 1.1240	0.625	1.1260 / 1.1240
	0.750	1.2505 / 1.2500	1.2495 / 1.2490	0.750	1.2510 / 1.2490
	1.000	1.5630 / 1.5625	1.5620 / 1.5615	1.000	1.5635 / 1.5615
	1.250	2.0010 / 2.0000	1.9993 / 1.9983	1.250	2.0010 / 1.9990
	1.500	2.3760 / 2.3750	2.3743 / 2.3733	1.500	2.3760 / 2.3740
	2.000	3.0010 / 3.0000	2.9992 / 2.9982	2.000	3.0010 / 2.9990

Dimensions & Specifications: LBCA Precision Ball Bushing (closed)

Model Number	Without Seals	With Seals ⁽²⁾	Nominal Shaft Diameter (inches)	Working Bore Diameter (inches)	Dyn. Load Capacity ⁽¹⁾ (lbs)	Dimensions (inches)				Bearing Weight (lbs)
						A	B	C	D	
LBCA-4	-S		0.250	0.2500/0.2495	19	0.750/0.735	0.515/0.499	0.039	0.5000/0.4996	0.02
LBCA-6	-S		0.375	0.3750/0.3745	37	0.875/0.860	0.640/0.624	0.039	0.6250/0.6246	0.06
LBCA-8	-S		0.500	0.5000/0.4995	85	1.250/1.235	0.967/0.951	0.046	0.8750/0.8746	0.08
LBCA-10	-S		0.625	0.6250/0.6245	150	1.500/1.485	1.108/1.092	0.056	1.1250/1.1246	0.16
LBCA-12	-S		0.750	0.7500/0.7495	200	1.625/1.610	1.170/1.154	0.056	1.2500/1.2496	0.21
LBCA-16	-S		1.000	1.0000/0.9995	350	2.250/2.235	1.759/1.741	0.068	1.5625/1.5621	0.38
LBCA-20	-S		1.250	1.2500/1.2494	520	2.625/2.605	2.009/1.991	0.068	2.0000/1.9995	1.10
LBCA-24	-S		1.500	1.5000/1.4994	770	3.000/2.980	2.415/2.397	0.086	2.3750/2.3745	1.43
LBCA-32	-S		2.000	2.0000/1.9992	1,100	4.000/3.980	3.195/3.177	0.103	3.0000/2.9994	2.75

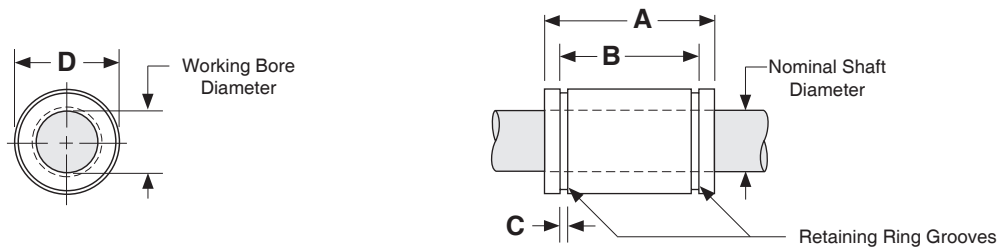

Dimensions & Specifications: LBOA Precision Ball Bushing (open)

Model Number	Without Seals	With Seals ⁽²⁾	Nominal Shaft Diameter (inches)	Working Bore Diameter (inches)	Dyn. Load Capacity ⁽¹⁾ (lbs)	Dimensions (inches)					Bearing Weight (lbs)
						A	B	C	D	E min.	
LBOA-8	-S		0.500	0.5005/0.4995	60	1.250/1.235	0.967/0.951	0.046	0.8760/0.8746	0.31	0.07
LBOA-10	-S		0.625	0.6255/0.6245	105	1.500/1.485	1.108/1.092	0.056	1.1260/1.1240	0.38	0.11
LBOA-12	-S		0.750	0.7505/0.7495	140	1.625/1.610	1.170/1.154	0.056	1.2510/1.2490	0.44	0.17
LBOA-16	-S		1.000	1.0005/0.9995	240	2.250/2.235	1.759/1.741	0.068	1.5635/1.5615	0.56	0.32
LBOA-20	-S		1.250	1.2506/1.2494	400	2.625/2.605	2.009/1.991	0.068	2.0010/1.9990	0.63	0.90
LBOA-24	-S		1.500	1.5006/1.4994	600	3.000/2.980	2.415/2.397	0.086	2.3760/2.3740	0.75	1.12
LBOA-32	-S		2.000	2.0008/1.9992	860	4.000/3.980	3.195/3.177	0.103	3.0010/2.9990	1.00	2.16

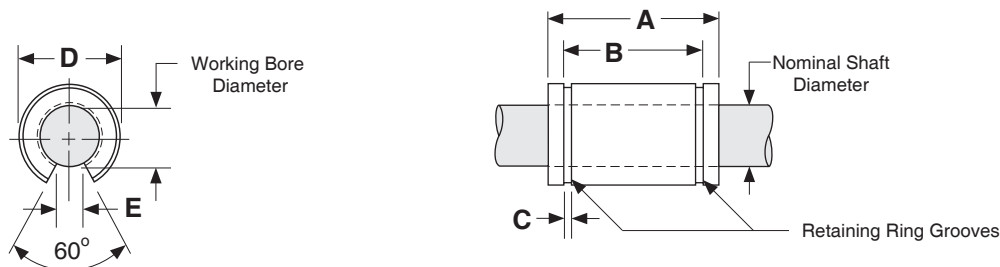

Footnotes:

- (1) Rating based upon 2 million inches of travel with the load forces being applied downward on the linear bearing, while in a horizontal application, and based upon 1060 steel shafting (Rockwell 60C). The actual load rating, and life, is dependent upon factors detailed on pages 6 to 13.
- (2) The bearing retainer is plastic when the internal -S seal option is selected.



LBC - **12** - **S** - **CR**

Linear Bushing Inch Series

- LBC** - Linear Bushing Closed
- LBO** - Linear Bushing Open

Nominal Diameter

- 4** - 0.250 inch diameter
- 6** - 0.375 inch diameter
- 8** - 0.500 inch diameter
- 10** - 0.625 inch diameter
- 12** - 0.750 inch diameter
- 16** - 1.000 inch diameter
- 20** - 1.250 inch diameter
- 24** - 1.500 inch diameter
- 32** - 2.000 inch diameter

Bushing Seals

- No Seals
- S** - Integral Seals at both ends

Bushing Options

- No Corrosion Resistance
- CR** - Corrosion Resistance

Specifications: LBC & LBO Linear Bushings (self-aligning)

Operating Temperature	0° F to + 185° F
Maximum Speed	9.8 ft/sec (3m/sec)
Bushing Seals	Optional Internal Wiper Seals on both ends
Matching Shaft	Class L (SL series), hardened & ground shafting (see pages 44 - 45)
Corrosion Resistance	Electroless nickel plated load plates and stainless steel recirculating balls

Housing and Shaft Diameter Tolerances C = clearance P = preload

Nominal Shaft Diameter (inches)	Shaft Diameter Tolerance g6 (inches)	Recommended Housing Bore		Bushing and Shaft Fit-up (before adjustment)	
		Fixed Housing (inches)	Adjustable Housing (inches)	Fixed Housing (inches)	Adjustable Housing (inches)
0.250	-.0002 / -.0006	.5005 / .5000	.5010 / .5000	.0015C / .0000	.002C / .0000
0.375	-.0002 / -.0006	.6255 / .6250	.6260 / .6250	.0015C / .0000	.002C / .0000
0.500	-.0002 / -.0007	.8755 / .8750	.8760 / .8750	.0015C / .0000	.002C / .0000
0.625	-.0002 / -.0007	1.1255 / 1.1250	1.1260 / 1.1250	.0015C / .0000	.002C / .0000
0.750	-.0003 / -.0008	1.2505 / 1.2500	1.2510 / 1.2500	.0015C / .0000	.002C / .0000
1.000	-.0003 / -.0008	1.5630 / 1.5625	1.5635 / 1.5625	.0015C / .0000	.002C / .0000
1.250	-.0004 / -.0010	2.0008 / 2.0000	2.0010 / 2.0000	.0018C / .0001P	.002C / .0000
1.500	-.0004 / -.0010	2.3760 / 2.3750	2.3760 / 2.3750	.0021C / .0000	.0021C / .0000
2.000	-.0004 / -.0012	3.0010 / 3.0000	3.0010 / 3.0000	.0023C / .0002P	.0023C / .0002P

Dimensions & Specifications: **LBC** Linear Bushing (closed)

Model Number	Without Seals	With Seals	Nominal Shaft Diameter (inches)	Dyn. Load Capacity (lbs)	# of Ball circuits	Working Bore Diameter (inches)	Housing Bore D (inches)	Dimensions (inches)			Bearing Weight (lbs)
								A	B	C	
LBC-4	-S		0.250	60	4	0.2500/0.2495	0.5005/0.5000	0.750/0.735	0.511/0.501	0.039	0.01
LBC-6	-S		0.375	100	4	0.3750/0.3745	0.6255/0.6250	0.875/0.860	0.699/0.689	0.039	0.02
LBC-8	-S		0.500	245	4	0.5000/0.4995	0.8755/0.8750	1.250/1.230	1.032/1.012	0.050	0.04
LBC-10	-S		0.625	430	5	0.6250/0.6245	1.1255/1.1250	1.500/1.480	1.105/1.095	0.056	0.10
LBC-12	-S		0.750	580	6	0.7500/0.7495	1.2505/1.2500	1.625/1.605	1.270/1.250	0.056	0.14
LBC-16	-S		1.000	980	6	1.0000/0.9995	1.5630/1.5625	2.250/2.230	1.884/1.864	0.068	0.25
LBC-20	-S		1.250	1,460	6	1.2500/1.2494	2.0008/2.0000	2.625/2.600	2.004/1.984	0.068	0.45
LBC-24	-S		1.500	1,830	6	1.5000/1.4994	2.3760/2.3750	3.000/2.970	2.410/2.390	0.086	0.85
LBC-32	-S		2.000	2,830	6	2.0000/1.9992	3.0010/3.0000	4.000/3.960	3.206/3.176	0.105	1.45

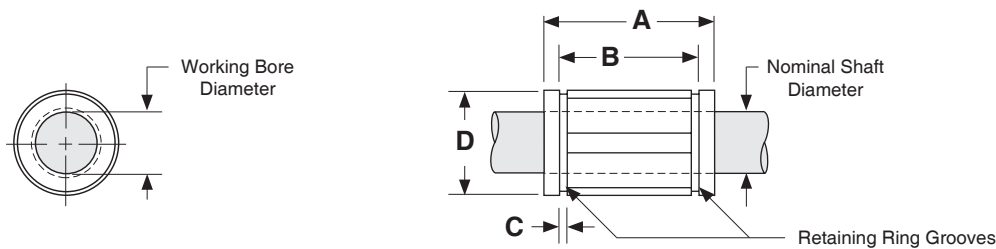

Dimensions & Specifications: **LBO** Linear Bushing (open)

Model Number	Without Seals	With Seals	Nominal Shaft Diameter (inches)	Dyn. Load Cap. (lbs)	# of Ball circuits	Working Bore Diameter (inches)	Housing Bore D (inches)	Dimensions (inches)					Retention Hole F dia.	G (in)	Bearing Weight (lbs)
								A	B	C	E min.	F dia.			
LBO-8	-S		0.500	230	4	0.5000/0.4995	0.8755/0.8750	1.250/1.230	1.032/1.012	0.050	0.312	.14	.63	0.04	
LBO-10	-S		0.625	380	4	0.6250/0.6245	1.1255/1.1250	1.500/1.480	1.105/1.095	0.056	0.375	.11	.13	0.08	
LBO-12	-S		0.750	470	5	0.7500/0.7495	1.2505/1.2500	1.625/1.605	1.270/1.250	0.056	0.437	.14	.13	0.12	
LBO-16	-S		1.000	820	5	1.0000/0.9995	1.5630/1.5625	2.250/2.230	1.884/1.864	0.068	0.562	.14	.13	0.21	
LBO-20	-S		1.250	1,210	5	1.2500/1.2494	2.0008/2.0000	2.625/2.600	2.004/1.984	0.068	0.625	.20	.19	0.38	
LBO-24	-S		1.500	1,520	5	1.5000/1.4994	2.3760/2.3750	3.000/2.970	2.410/2.390	0.086	0.750	.20	.19	0.71	
LBO-32	-S		2.000	2,410	5	2.0000/1.9992	3.0010/3.0000	4.000/3.960	3.206/3.176	0.103	1.105	.27	.31	1.20	

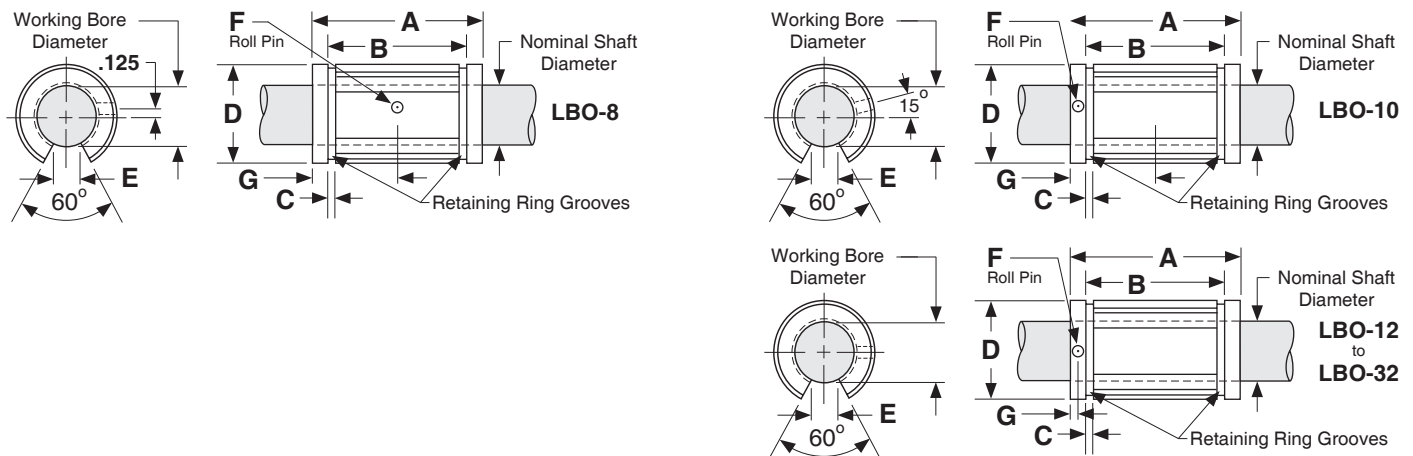

Footnotes:

- (1) Rating based upon 2 million inches of travel with the load forces being applied downward on the linear bushing, while in a horizontal application, and based upon 1060 steel shafting (Rockwell 60C). The actual load rating, and life, is dependent upon factors detailed on pages 6 to 13.
- (2) This specification is based upon the bushing being on the shaft. Refer to page 42 for additional details.

Specifications subject to change without notice

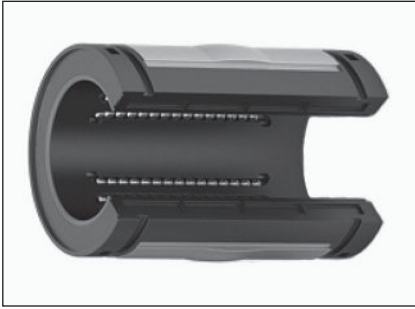
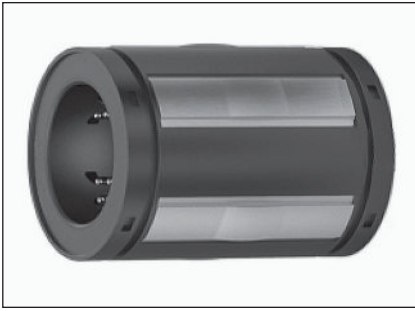

LBCH - **12** - **S** - **CR**

Linear Bushing High Capacity

- LBCH** - Linear Bushing Closed - High Capacity
- LBOH** - Linear Bushing Open - High Capacity

Nominal Diameter

- 12** - 0.750 inch diameter **20** - 1.250 inch diameter
- 16** - 1.000 inch diameter **24** - 1.500 inch diameter

Bushing Seals

- No Seals
- S** - Integral Seals at both ends

Bushing Options

- No Corrosion Resistance
- CR** - Corrosion Resistance

Specifications: **LBCH** & **LBOH** High Capacity Linear Bushings (self-aligning)

Operating Temperature	0° F to + 185° F
Maximum Speed	9.8 ft/sec (3m/sec)
Bushing Seals	Optional Internal Wiper Seals on both ends
Matching Shaft	Class L (SL series), hardened & ground shafting (see pages 44 - 45)
Corrosion Resistance	Electroless nickel plated load plates and stainless steel recirculating balls

Housing and Shaft Diameter Tolerances **C** = clearance **P** = preload

Nominal Shaft Diameter (inches)	Shaft Diameter Tolerance g6 (inches)	Recommended Housing Bore		Bushing and Shaft Fit-up (before adjustment)	
		Fixed Housing (inches)	Adjustable Housing (inches)	Fixed Housing (inches)	Adjustable Housing (inches)
0.750	-.0003 / -.0008	1.2505 / 1.2500	1.2510 / 1.2500	.0015C / .0000	.002C / .0000
1.000	-.0003 / -.0008	1.5630 / 1.5625	1.5635 / 1.5625	.0015C / .0000	.002C / .0000
1.250	-.0004 / -.0010	2.0008 / 2.0000	2.0010 / 2.0000	.0018C / .0001P	.002C / .0000
1.500	-.0004 / -.0010	2.3760 / 2.3750	2.3760 / 2.3750	.0021C / .0000	.0021C / .0000

Dimensions & Specifications: **LBCH** High Capacity Linear Bushing (closed)

Model Number Without Seals With Seals	Nominal Shaft Diameter (inches)	Dyn. Load Capacity ⁽¹⁾ (lbs)	# of Ball circuits	Working Bore Diameter (inches)	Housing Bore D ⁽²⁾ (inches)	Dimensions (inches)			Bearing Weight (lbs)
						A	B	C	
LBCH-12 -S	0.750	1,130	10	0.7500/0.7495	1.2505/1.2500	1.625/1.605	1.285/1.255	0.056	0.13
LBCH-16 -S	1.000	1,900	10	1.0000/0.9995	1.5630/1.5625	2.250/2.230	1.901/1.871	0.068	0.28
LBCH-20 -S	1.250	2,350	10	1.2500/1.2494	2.0008/2.0000	2.625/2.600	2.031/1.991	0.068	0.53
LBCH-24 -S	1.500	3,880	10	1.5000/1.4994	2.3760/2.3750	3.000/2.970	2.442/2.402	0.086	0.84

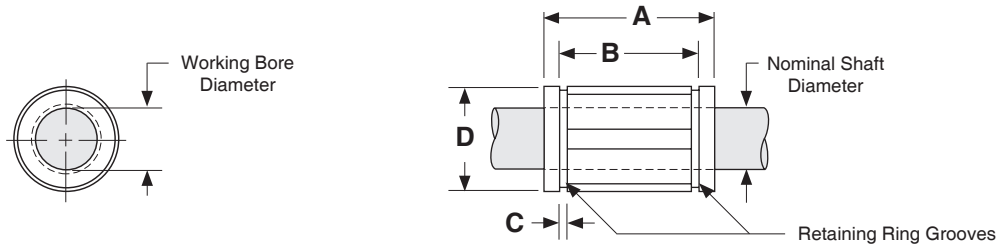

Dimensions & Specifications: **LBOH** High Capacity Linear Bushing (open)

Model Number Without Seals With Seals	Nominal Shaft Diameter (inches)	Dyn. Load Cap. ⁽¹⁾ (lbs)	# of Ball circuits	Working Bore Diameter (inches)	Housing Bore D ⁽²⁾ (inches)	Dimensions (inches)					Retention Hole		Bearing Weight (lbs)
						A	B	C	E min.	F dia.	G (in)		
LBOH-12 -S	0.750	1,130	8	0.7500/0.7495	1.2505/1.2500	1.625/1.605	1.285/1.255	0.056	0.44	.14	.13	0.11	
LBOH-16 -S	1.000	1,900	8	1.0000/0.9995	1.5630/1.5625	2.250/2.230	1.901/1.871	0.068	0.56	.14	.13	0.23	
LBOH-20 -S	1.250	2,350	8	1.2500/1.2494	2.0008/2.0000	2.625/2.600	2.031/1.991	0.068	0.63	.20	.19	0.43	
LBOH-24 -S	1.500	3,380	8	1.5000/1.4994	2.3760/2.3750	3.000/2.970	2.442/2.402	0.086	0.75	.20	.19	0.68	

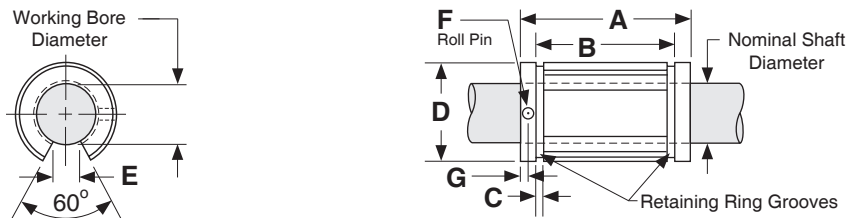

Footnotes:

- (1) Rating based upon 2 million inches of travel with the load forces being applied downward on the linear bushing, while in a horizontal application, and based upon 1060 steel shafting (Rockwell 60C). The actual load rating, and life, is dependent upon factors detailed on pages 6 to 13.
- (2) This specification is based upon the bushing being on the shaft. Refer to page 42 for additional details.



LBCM - **16** - **S**

Linear Bushing Metric Asian

- LBCM** - Asian Super Metric Bushing Closed
- LBOM** - Asian Super Metric Bushing Open

Nominal Diameter

- 16** - 16 mm diameter **30** - 30 mm diameter
- 20** - 20 mm diameter **40** - 40 mm diameter
- 25** - 25 mm diameter

Bushing Seals

- No Seals
- S** - Integral Seals at both ends

Specifications: LBCM & LBOM Linear Bushings Metric (self-aligning)

Operating Temperature	-20° C to +80° C
Maximum Speed	3 meters/sec
Bushing Seals	Optional Internal Wiper Seals on both ends
Matching Shaft	Metric (SM series), hardened & ground shafting (see pages 46 - 47)

Housing and Shaft Diameter Tolerances

Nominal Shaft Diameter (mm)	Shaft Diameter Tolerance h6 (mm)	Recommended Housing Bore D (mm)	Housing Bore Tolerance H7 (mm)
16	0 / -0.011	26	+0.021 / 0
20	0 / -0.013	32	+0.025 / 0
25	0 / -0.013	40	+0.025 / 0
30	0 / -0.013	47	+0.025 / 0
40	0 / -0.016	62	+0.030 / 0

Dimensions & Specifications: LBCM Linear Bushing Closed Metric (Asian Style)

Model Number		Nominal Shaft Diameter (mm)	Dynamic Load Capacity (N)	Housing Bore D (mm)	Dimensions (mm)			# of Ball Circuits	Bearing Weight (g)
Without Seals	With Seals				A	B	C		
LBCM-16	-S	16	1225	28	37	26,5	1,60	5	34
LBCM-20	-S	20	2303	32	42	30,5	1,60	6	58
LBCM-25	-S	25	4312	40	59	41,0	1,85	6	120
LBCM-30	-S	30	4802	45	64	44,5	1,85	6	148
LBCM-40	-S	40	9310	60	80	60,5	2,10	6	314

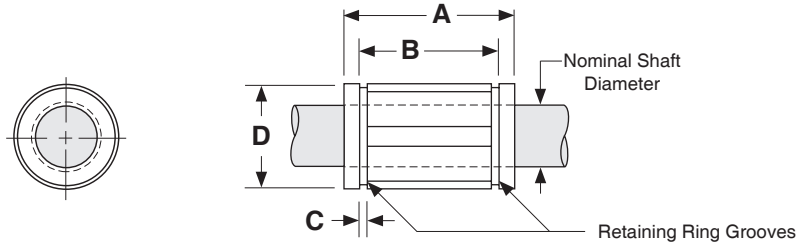

Dimensions & Specifications: LBOM Linear Bushing Open Metric (Asian Style)

Model Number		Nominal Shaft Diameter (mm)	Dynamic Load Capacity (N)	Housing Bore D (mm)	Dimensions (mm)				Angle a	# of Ball Circuits	Bearing Weight (g)
Without Seals	With Seals				A	B	C	E min.			
LBOM-16	-S	16	1372	28	37	26,5	1,60	11,0	60°	4	26
LBOM-20	-S	20	2332	32	42	30,5	1,60	11,0	60°	5	48
LBOM-25	-S	25	4351	40	59	41,0	1,85	12,5	60°	5	100
LBOM-30	-S	30	4851	45	64	44,5	1,85	15,0	60°	5	122
LBOM-40	-S	40	9408	60	80	60,5	2,15	20,0	60°	5	262

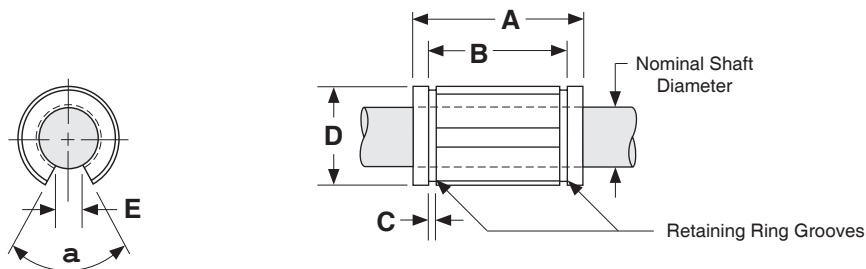

Footnotes:

- (1) Rating based upon 50 km of travel with the load forces being applied downward on the linear bearing, while in a horizontal application, and based upon 1060 steel shafting (Rockwell 60C).
- (2) This specification is based upon the bearing being on the shaft.



LBCME - **20** - **S** - **CR**

Linear Bushing Metric European

- LBCME** - European Super Metric Bushing Closed
- LBOME** - European Super Metric Bushing Open

Nominal Diameter

- 8** - 8 mm diameter
- 10** - 10 mm diameter
- 12** - 12 mm diameter
- 16** - 16 mm diameter
- 20** - 20 mm diameter
- 25** - 25 mm diameter
- 30** - 30 mm diameter
- 40** - 40 mm diameter
- 50** - 50 mm diameter

Bushing Seals

- No Seals
- S** - Integral Seals at both ends

Bushing Options

- No Corrosion Resistance
- CR** - Corrosion Resistance

Specifications: **LBCME** & **LBOME** Linear Bushings Metric (self-aligning)

Operating Temperature	-20° C to +80° C
Maximum Speed	3 meters/sec
Bushing Seals	Optional Internal Wiper Seals on both ends
Matching Shaft	Metric (SM series), hardened & ground shafting (see pages 46 - 47)
Corrosion Resistance	Electroless nickel plated load plates and stainless steel recirculating balls

Housing and Shaft Diameter Tolerances

Nominal Shaft Diameter (mm)	Shaft Diameter Tolerance h6 (mm)	Recommended Housing Bore D (mm)	Housing Bore Tolerance H7 (mm)
8	0 / -0.009	16	+0.018 / 0
10	0 / -0.009	19	+0.021 / 0
12	0 / -0.011	22	+0.021 / 0
16	0 / -0.011	26	+0.021 / 0
20	0 / -0.013	32	+0.025 / 0
25	0 / -0.013	40	+0.025 / 0
30	0 / -0.013	47	+0.025 / 0
40	0 / -0.016	62	+0.030 / 0
50	0 / -0.016	75	+0.030 / 0

Dimensions & Specifications: LBCME Linear Bushing Closed Metric (European Style)

Model Number		Nominal Shaft Diameter (mm)	Dynamic Load Capacity (N)	Housing Bore D (mm)	Dimensions (mm)			# of Ball Circuits	Bearing Weight (g)
Without Seals	With Seals				A	B	C		
LBCME- 8	-S	8	423	16	25	16,5	1,10	4	7.3
LBCME-10	-S	10	750	19	29	22,0	1,30	5	14
LBCME-12	-S	12	1020	22	32	22,9	1,30	5	21
LBCME-16	-S	16	1250	26	36	24,9	1,30	5	43
LBCME-20	-S	20	2090	32	45	31,5	1,60	6	58
LBCME-25	-S	25	3780	40	58	44,1	1,85	6	123
LBCME-30	-S	30	5470	47	68	52,1	1,85	6	216
LBCME-40	-S	40	6590	62	80	60,6	2,15	6	333
LBCME-50	-S	50	10800	75	100	77,6	2,65	6	618

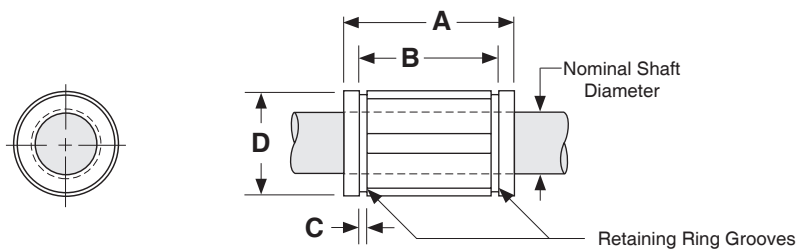

Dimensions & Specifications: LBOME Linear Bushing Open Metric (European Style)

Model Number		Nominal Shaft Diameter (mm)	Dynamic Load Capacity (N)	Housing Bore D (mm)	Dimensions (mm)				Angle	# of Ball Circuits	Bearing Weight (g)
Without Seals	With Seals				A	B	C	E min.	a		
LBOME-12	-S	12	1020	22	32	22,9	1,30	6,5	66°	4	17
LBOME-16	-S	16	1250	26	36	24,9	1,30	9,0	68°	4	35
LBOME-20	-S	20	2090	32	45	31,5	1,60	9,0	55°	5	48
LBOME-25	-S	25	3780	40	58	44,1	1,85	11,5	57°	5	103
LBOME-30	-S	30	5470	47	68	52,1	1,85	14,0	57°	5	177
LBOME-40	-S	40	6590	62	80	60,6	2,15	19,5	56°	5	275
LBOME-50	-S	50	10800	75	100	77,6	2,65	22,5	54°	5	520

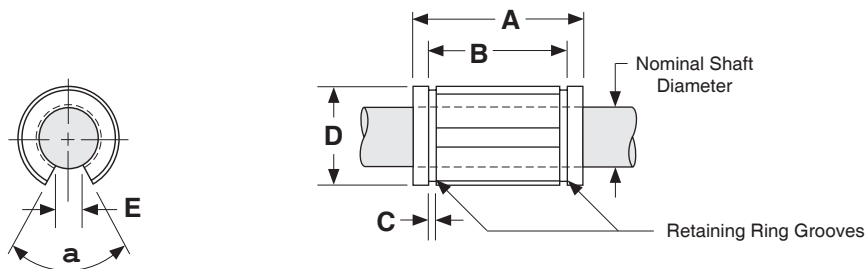

Footnotes:

- (1) Rating based upon 50 km of travel with the load forces being applied downward on the linear bearing, while in a horizontal application, and based upon 1060 steel shafting (Rockwell 60C).
- (2) This specification is based upon the bearing being on the shaft.



SLBC - **10** - **CR** - **L**

Pillow Block Series

- SLBC** - One LBC bushing per pillow block
- DLBC** - Two LBC bushings per pillow block
- SLBO** - One LBO bushing per pillow block
- DLBO** - Two LBO bushings per pillow block
- SLBCH** - One LBCH bushing per pillow block
- DLBCH** - Two LBCH bushings per pillow block
- SLBOH** - One LBOH bushing per pillow block
- DLBOH** - Two LBOH bushings per pillow block

Nominal Diameter

- 8** - 0.500 inch diameter
- 10** - 0.625 inch diameter
- 12** - 0.750 inch diameter
- 16** - 1.000 inch diameter
- 20** - 1.250 inch diameter
- 24** - 1.500 inch diameter
- 32** - 2.000 inch diameter

Bearing Options

- Standard
- CR** - Corrosion Resistance

Bearing Lock

- None
- L** - Hand Wheel Lock

Specifications: Pillow Blocks (self-aligning)

Bearing Housing Type & Finish	Aluminum 6061-T6 Pillow Block, Clear Anodized																
Bearing Seals	Internal Wiper Seals on Both Ends																
Corrosion Resistance	Electroless nickel plated load bushing plates and stainless steel recirculating balls																
Hand Wheel Lock	Optional Aluminum Shaft Clamping Block (see page 39)																
Operating Temperature	0° F to +185° F																
Maximum Speed	9.8 ft/second (3m/sec)																
Matching Shaft	Class L (SL series), hardened & ground shafting (see pages 44 - 45)																
Diameter Tolerance	<table border="1"> <thead> <tr> <th>Nominal Shaft Diameter (inches)</th> <th>Shaft Diameter Tolerance (inches)</th> </tr> </thead> <tbody> <tr> <td>0.500</td> <td>.4995 / .4990</td> </tr> <tr> <td>0.625</td> <td>.6245 / .6240</td> </tr> <tr> <td>0.750</td> <td>.7495 / .7490</td> </tr> <tr> <td>1.000</td> <td>.9995 / .9990</td> </tr> <tr> <td>1.250</td> <td>1.2495 / 1.2490</td> </tr> <tr> <td>1.500</td> <td>1.4994 / 1.4989</td> </tr> <tr> <td>2.000</td> <td>1.9994 / 1.9987</td> </tr> </tbody> </table>	Nominal Shaft Diameter (inches)	Shaft Diameter Tolerance (inches)	0.500	.4995 / .4990	0.625	.6245 / .6240	0.750	.7495 / .7490	1.000	.9995 / .9990	1.250	1.2495 / 1.2490	1.500	1.4994 / 1.4989	2.000	1.9994 / 1.9987
Nominal Shaft Diameter (inches)	Shaft Diameter Tolerance (inches)																
0.500	.4995 / .4990																
0.625	.6245 / .6240																
0.750	.7495 / .7490																
1.000	.9995 / .9990																
1.250	1.2495 / 1.2490																
1.500	1.4994 / 1.4989																
2.000	1.9994 / 1.9987																

Dimensions & Specifications: **SLBC** Single Linear Bearing Closed Pillow Block (self-aligning)

Model Number	Nominal Shaft Diameter (inches)	Dyn. Load Capacity (lbs)	Dimensions (inches)											Block Weight (lbs)
			A	B	C	D	E	F	G	H	I	J		
			+/- .003				+/- .010	+/- .010				hole	bolt	
SLBC-8	0.500	245	0.687	2.00	1.69	1.13	1.688	1.000	1.38	1.25	.25	.16	# 6	0.20
SLBC-10	0.625	430	0.875	2.50	1.94	1.44	2.125	1.125	1.75	1.63	.28	.19	# 8	0.50
SLBC-12	0.750	580	0.937	2.75	2.06	1.56	2.375	1.250	1.88	1.75	.31	.19	# 8	0.60
SLBC-16	1.000	980	1.187	3.25	2.81	1.94	2.875	1.750	2.38	2.19	.38	.22	#10	1.20
SLBC-20	1.250	1,460	1.500	4.00	3.63	2.50	3.500	2.000	3.00	2.81	.44	.22	#10	2.50
SLBC-24	1.500	1,830	1.750	4.75	4.00	2.88	4.125	2.500	3.50	3.25	.50	.28	1/4	3.80
SLBC-32	2.000	2,830	2.125	6.00	5.00	3.63	5.250	3.250	4.50	4.06	.63	.41	3/8	7.00

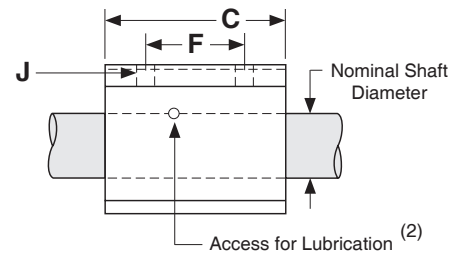
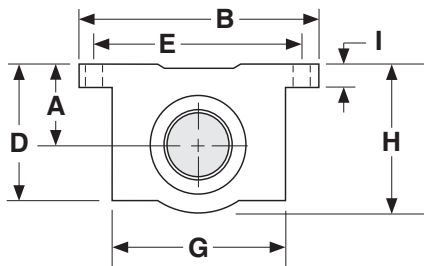

Dimensions & Specifications: **SLBO** Single Linear Bearing Open Pillow Block (self-aligning)

Model Number	Nominal Shaft Diameter (inches)	Dyn. Load Capacity (lbs)	Dimensions (inches)													Block Weight (lbs)
			A	B	C	D	E	F	G	H		I	J	K		
			+/- .003				+/- .010	+/- .010		hole	bolt		min.			
SLBO-8	0.500	230	0.687	2.00	1.50	1.13	1.688	1.000	0.69	.16	# 6	.25	0.31	0.75	0.20	
SLBO-10	0.625	380	0.875	2.50	1.75	1.44	2.125	1.125	0.88	.19	# 8	.28	0.37	0.94	0.40	
SLBO-12	0.750	470	0.937	2.75	1.88	1.56	2.375	1.250	0.94	.19	# 8	.31	0.43	1.00	0.50	
SLBO-16	1.000	820	1.187	3.25	2.63	2.00	2.875	1.750	1.19	.22	#10	.38	0.56	1.25	1.00	
SLBO-20	1.250	1,210	1.500	4.00	3.38	2.56	3.500	2.000	1.50	.22	#10	.44	0.62	1.63	2.10	
SLBO-24	1.500	1,520	1.750	4.75	3.75	2.94	4.125	2.500	1.75	.28	1/4	.50	0.75	1.88	3.20	
SLBO-32	2.000	2,410	2.125	6.00	4.75	3.63	5.250	3.250	2.25	.41	3/8	.63	1.00	2.44	6.00	

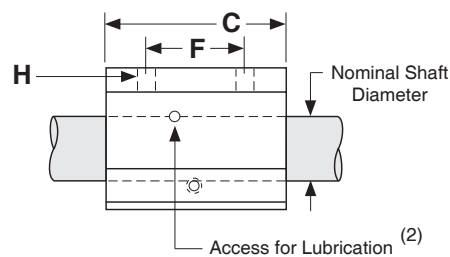
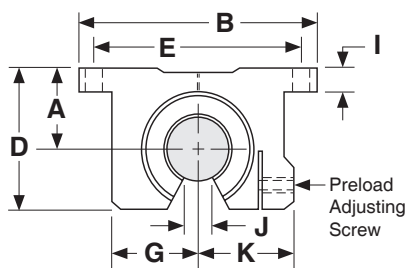

Footnotes:

- (1) Rating based upon 2 million inches of travel with the load forces being applied downward on the linear bearing, while in a horizontal application, and based upon 1060 steel shafting (Rockwell 60C). The actual load rating, and life, is dependent upon factors detailed on pages 6 to 13.
- (2) Size 0.500 has oil lubricant fitting. Sizes 0.625 and above have a 1/4-28 UNF straight thread access for lubrication.

Dimensions & Specifications: DLBC Double Linear Bearing Closed Pillow Block (self-aligning)

Model Number	Nominal Shaft Diameter (inches)	Dyn. Load Capacity (lbs) ⁽¹⁾	Dimensions (inches)											Block Weight (lbs)	
			A	B	C	D	E	F	G	H	I	J			d ₂ ⁽³⁾
			+/- .003				+/- .010	+/- .010					hole		
DLBC-8	0.500	490	0.687	2.00	3.50	1.13	1.688	2.500	1.38	1.25	.25	.16	# 6	1.75	0.40
DLBC-10	0.625	860	0.875	2.50	4.00	1.44	2.125	3.000	1.75	1.63	.28	.19	# 8	2.00	1.00
DLBC-12	0.750	1,160	0.937	2.75	4.50	1.56	2.375	3.500	1.88	1.75	.31	.19	# 8	2.25	1.20
DLBC-16	1.000	1,960	1.187	3.25	6.00	1.94	2.875	4.500	2.38	2.19	.38	.22	#10	3.00	2.40
DLBC-20	1.250	2,920	1.500	4.00	7.50	2.50	3.500	5.500	3.00	2.81	.44	.22	#10	3.75	5.00
DLBC-24	1.500	3,660	1.750	4.75	9.00	2.88	4.125	6.500	3.50	3.25	.50	.28	1/4	4.50	7.80
DLBC-32	2.000	5,660	2.125	6.00	10.00	3.63	5.250	8.250	4.50	4.06	.63	.41	3/8	5.75	14.50

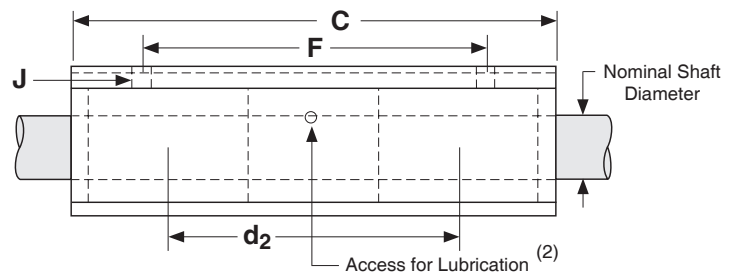
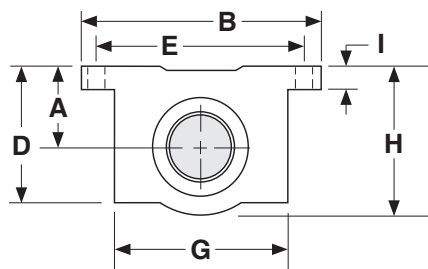

Dimensions & Specifications: DLBO Double Linear Bearing Pillow Block Open (self-aligning)

Model Number	Nominal Shaft Diameter (inches)	Dyn. Load Capacity (lbs) ⁽¹⁾	Dimensions (inches)													Block Weight (lbs)
			A	B	C	D	E	F	G	H	I	J		K	d ₂ ⁽³⁾	
			+/- .003				+/- .010	+/- .010		min.			hole	bolt		
DLBO-8	0.500	460	0.687	2.00	3.50	1.13	1.688	2.500	0.69	.31	.25	.16	# 6	0.75	1.75	0.40
DLBO-10	0.625	760	0.875	2.50	4.00	1.44	2.125	3.000	0.88	.37	.28	.19	# 8	0.94	2.00	0.80
DLBO-12	0.750	940	0.937	2.75	4.50	1.56	2.375	3.500	0.94	.43	.31	.19	# 8	1.00	2.25	1.00
DLBO-16	1.000	1,640	1.187	3.25	6.00	2.00	2.875	4.500	1.19	.56	.38	.22	#10	1.25	3.00	2.00
DLBO-20	1.250	2,420	1.500	4.00	7.50	2.56	3.500	5.500	1.50	.62	.44	.22	#10	1.63	3.75	4.20
DLBO-24	1.500	3,040	1.750	4.75	9.00	2.94	4.125	6.500	1.75	.75	.50	.28	1/4	1.88	4.50	6.70
DLBO-32	2.000	4,820	2.125	6.00	10.00	3.63	5.250	8.250	2.25	1.00	.63	.41	3/8	2.44	5.75	12.75

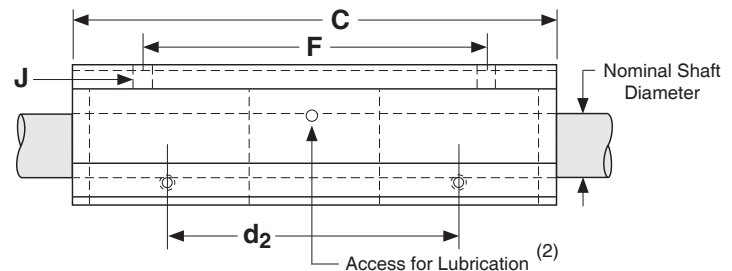
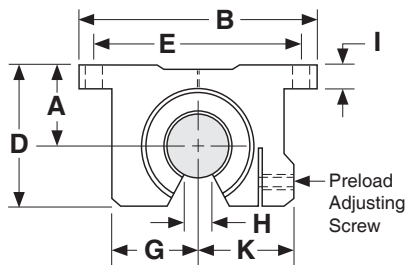

Footnotes:

(1) Rating based upon 2 million inches of travel with the load forces being applied downward on the linear bearing, while in a horizontal application, and based upon 1060 steel shafting (Rockwell 60C). The actual load rating, and life, is dependent upon factors detailed on pages 6 to 13.

(2) Size 0.500 has oil lubricant fitting. Sizes 0.625 and above have a 1/4-28 UNF straight thread access for lubrication.

(3) This value is the center to center distance (spacing) of the bearings on a single shaft (d₂).

Dimensions & Specifications: **SLBCH** Single Linear Bearing Closed Pillow Block (self-aligning)

Model Number	Nominal Shaft Diameter (inches)	Dyn. (1) Load Capacity (lbs)	Dimensions (inches)											Block Weight (lbs)
			A	B	C	D	E	F	G	H	I	J		
			+/- .003				+/- .010	+/- .010				hole	bolt	
SLBCH-12	0.750	1,130	0.937	2.75	2.06	1.56	2.375	1.250	1.88	1.75	.31	.19	# 8	0.60
SLBCH-16	1.000	1,900	1.187	3.25	2.81	1.94	2.875	1.750	2.38	2.19	.38	.22	#10	1.20
SLBCH-20	1.250	2,350	1.500	4.00	3.63	2.50	3.500	2.000	3.00	2.81	.44	.22	#10	2.50
SLBCH-24	1.500	3,880	1.750	4.75	4.00	2.88	4.125	2.500	3.50	3.25	.50	.28	1/4	3.80

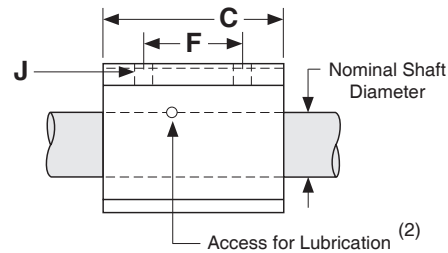
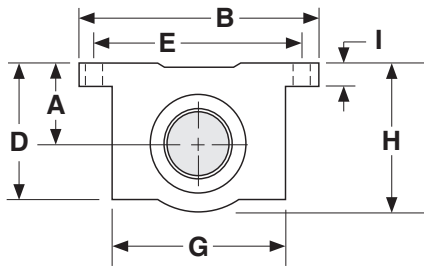

Dimensions & Specifications: **SLBOH** Single Linear Bearing Open Pillow Block (self-aligning)

Model Number	Nominal Shaft Diameter (inches)	Dyn. (1) Load Capacity (lbs)	Dimensions (inches)												Block Weight (lbs)
			A	B	C	D	E	F	G	H		I	J	K	
			+/- .003				+/- .010	+/- .010		hole	bolt		min.		
SLBOH-12	0.750	1,130	0.937	2.75	1.88	1.56	2.375	1.250	0.94	.19	# 8	.31	0.43	1.00	0.50
SLBOH-16	1.000	1,900	1.187	3.25	2.63	2.00	2.875	1.750	1.19	.22	#10	.38	0.56	1.25	1.00
SLBOH-20	1.250	2,350	1.500	4.00	3.38	2.56	3.500	2.000	1.50	.22	#10	.44	0.62	1.63	2.10
SLBOH-24	1.500	3,880	1.750	4.75	3.75	2.94	4.125	2.500	1.75	.28	1/4	.50	0.75	1.88	3.20

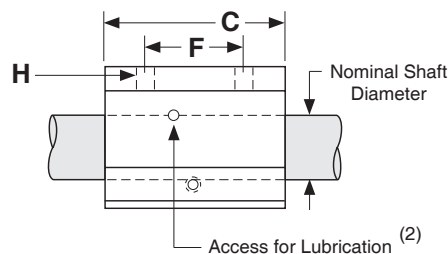
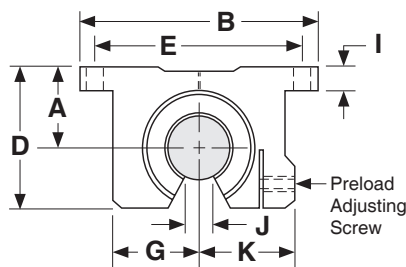

Footnotes:

- (1) Rating based upon 2 million inches of travel with the load forces being applied downward on the linear bearing, while in a horizontal application, and based upon 1060 steel shafting (Rockwell 60C). The actual load rating, and life, is dependent upon factors detailed on pages 6 to 13.
- (2) Sizes 0.625 and above have a 1/4-28 UNF straight thread access for lubrication.

Dimensions & Specifications: **DLBCH** Double Linear Bearing Closed Pillow Block (self-aligning)

Model Number	Nominal Shaft Diameter (inches)	Dyn. Load Capacity ⁽¹⁾ (lbs)	Dimensions (inches)											Block Weight (lbs)	
			A	B	C	D	E	F	G	H	I	J			d ₂ ⁽³⁾
			+/- .003				+/- .010	+/- .010				hole	bolt		
DLBCH-12	0.750	2,260	0.937	2.75	4.50	1.56	2.375	3.500	1.88	1.75	.31	.19	# 8	2.25	1.20
DLBCH-16	1.000	3,800	1.187	3.25	6.00	1.94	2.875	4.500	2.38	2.19	.38	.22	#10	3.00	2.40
DLBCH-20	1.250	4,700	1.500	4.00	7.50	2.50	3.500	5.500	3.00	2.81	.44	.22	#10	3.75	5.00
DLBCH-24	1.500	7,760	1.750	4.75	9.00	2.88	4.125	6.500	3.50	3.25	.50	.28	1/4	4.50	7.80

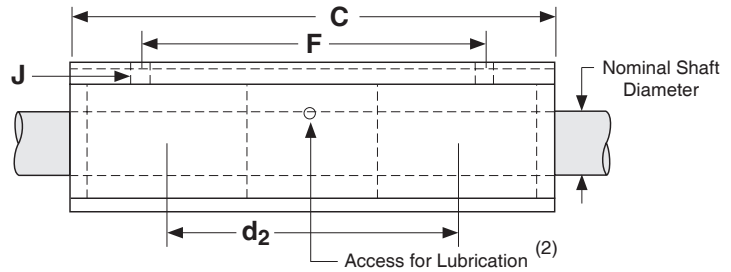
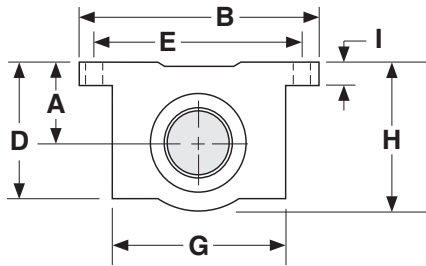

Dimensions & Specifications: **DLBOH** Double Linear Bearing Pillow Block Open (self-aligning)

Model Number	Nominal Shaft Diameter (inches)	Dyn. Load Capacity ⁽¹⁾ (lbs)	Dimensions (inches)													Block Weight (lbs)
			A	B	C	D	E	F	G	H	I	J		K	d ₂ ⁽³⁾	
			+/- .003				+/- .010	+/- .010		min.		hole	bolt			
DLBOH-12	0.750	2,260	0.937	2.75	4.50	1.56	2.375	3.500	0.94	.43	.31	.19	# 8	1.00	2.25	1.00
DLBOH-16	1.000	3,800	1.187	3.25	6.00	2.00	2.875	4.500	1.19	.56	.38	.22	#10	1.25	3.00	2.00
DLBOH-20	1.250	4,700	1.500	4.00	7.50	2.56	3.500	5.500	1.50	.62	.44	.22	#10	1.63	3.75	4.20
DLBOH-24	1.500	7,760	1.750	4.75	9.00	2.94	4.125	6.500	1.75	.75	.50	.28	1/4	1.88	4.50	6.70

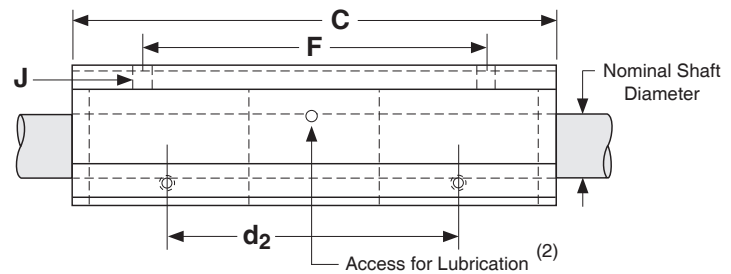
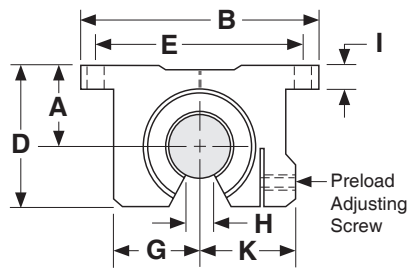

Footnotes:

(1) Rating based upon 2 million inches of travel with the load forces being applied downward on the linear bearing, while in a horizontal application, and based upon 1060 steel shafting (Rockwell 60C). The actual load rating, and life, is dependent upon factors detailed on pages 6 to 13.

(2) Sizes 0.625 and above have a 1/4-28 UNF straight thread access for lubrication.

(3) This value is the center to center distance (spacing) of the bearings on a single shaft (d₂).

TRCA 12 H - 12 - CR - P - L1

TWIN RAIL® Carriage Assembly

TRCA - Plate with SLBO, SLBOH, DLBO or DLBOH

Nominal Bearing Diameter

8 - 0.500 inch diameter	20 - 1.250 inch dia.
10 - 0.625 inch diameter	24 - 1.500 inch dia.
12 - 0.750 inch diameter	32 - 2.000 inch dia.
16 - 1.000 inch diameter	

Load Capacity

- Standard
- H** - High Capacity

Carriage Plate Length

6 - 6 inches	18 - 18 inches
8 - 8 inches	24 - 24 inches
12 - 12 inches	30 - 30 inches

Bearing Options

- Standard
- CR** - Corrosion Resistance

Carriage Plate Mounting

- No Holes
- P** - Pre-Machined Mounting Holes

Bearing Lock

- None
- Lx** - Hand Wheel Locks (x = number of locks - 1, 2, 3 or 4)

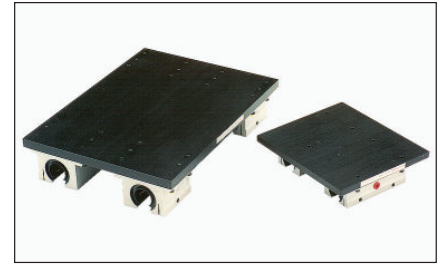

Specifications: **TRCA** TWIN RAIL® Carriage Assembly

Bearing Housing Type & Finish	Aluminum 6061-T6 Pillow Block, Clear Anodized																
Bearing Seals	Internal Wiper Seals on Both Ends																
Corrosion Resistance	Corrosion Resistant linear bushings and stainless steel mounting hardware																
Hand Wheel Locks	Optional Aluminum Shaft Clamping Blocks (see page 39)																
Carriage Plate Type & Finish	Machined Aluminum 6061-T6 Plate, Black Anodized																
Bearing Alignment on Plate	+/- 0.001", Pillow Blocks Doweled to Carriage Plate																
Carriage Plate Machining	Optional Pre-Machined Mounting Holes (see page 38)																
Operating Temperature	0° F to + 185° F																
Maximum Speed	9.8 ft/second (3m/sec)																
Matching Shaft Assembly	TRSA series (see pages 62 - 69)																
Diameter Tolerance	<table border="1" style="width: 100%; text-align: center;"> <thead> <tr> <th>Nominal Shaft Diameter (inches)</th> <th>Shaft Diameter Tolerance (inches)</th> </tr> </thead> <tbody> <tr> <td>0.500</td> <td>.4995 / .4990</td> </tr> <tr> <td>0.625</td> <td>.6245 / .6240</td> </tr> <tr> <td>0.750</td> <td>.7495 / .7490</td> </tr> <tr> <td>1.000</td> <td>.9995 / .9990</td> </tr> <tr> <td>1.250</td> <td>1.2495 / 1.2490</td> </tr> <tr> <td>1.500</td> <td>1.4994 / 1.4989</td> </tr> <tr> <td>2.000</td> <td>1.9994 / 1.9987</td> </tr> </tbody> </table>	Nominal Shaft Diameter (inches)	Shaft Diameter Tolerance (inches)	0.500	.4995 / .4990	0.625	.6245 / .6240	0.750	.7495 / .7490	1.000	.9995 / .9990	1.250	1.2495 / 1.2490	1.500	1.4994 / 1.4989	2.000	1.9994 / 1.9987
Nominal Shaft Diameter (inches)	Shaft Diameter Tolerance (inches)																
0.500	.4995 / .4990																
0.625	.6245 / .6240																
0.750	.7495 / .7490																
1.000	.9995 / .9990																
1.250	1.2495 / 1.2490																
1.500	1.4994 / 1.4989																
2.000	1.9994 / 1.9987																

Specifications subject to change without notice

Dimensions & Specifications: TRCA TWIN RAIL® Carriage Assembly

Model Number	Nom. Shaft Dia. (inches)	Dyn. Load Cap. (lbs)	Dimensions (inches)													Assembly Weight (lbs)
			A +/- .005	B +/- .005	C	D	E	F	G	H	J	K	d _r ⁽²⁾	d ₁ ⁽³⁾	d ₂ ⁽⁴⁾	
TRCA8-6	0.500	920	6.00	5.50	1.25	0.75	0.68	1.12	2.00	.25	3.50	0.375	1.062	3.00	1.90	2.4
TRCA8-12	0.500	920	12.00	5.50	0.25	0.75	0.68	1.12	2.00	.25	11.50	0.375	1.062	3.00	10.00	4.6
TRCA8-18	0.500	920	18.00	5.50	0.25	0.75	0.68	1.12	2.00	.25	17.50	0.375	1.062	3.00	16.00	5.9
TRCA10-6	0.625	1,520	6.00	6.75	1.00	0.93	0.87	1.43	2.50	.25	4.00	0.375	1.250	3.75	2.15	3.5
TRCA10-12	0.625	1,520	12.00	6.75	0.25	0.93	0.87	1.43	2.50	.25	11.50	0.375	1.250	3.75	9.75	6.0
TRCA10-18	0.625	1,520	18.00	6.75	0.25	0.93	0.87	1.43	2.50	.25	17.50	0.375	1.250	3.75	15.75	7.7
TRCA12-6	0.750	1,880	6.00	7.75	0.75	1.00	0.93	1.56	2.75	.25	4.50	0.500	1.437	4.50	2.50	4.8
TRCA12H-6		4,520														
TRCA12-12	0.750	1,880	12.00	7.75	0.25	1.00	0.93	1.56	2.75	.25	11.49	0.500	1.437	4.50	9.62	8.2
TRCA12H-12		4,520														
TRCA12-18	0.750	1,880	18.00	7.75	0.25	1.00	0.93	1.56	2.75	.25	17.49	0.500	1.437	4.50	15.62	10.7
TRCA12H-18		4,520														
TRCA16-6	1.000	3,280	6.00	9.00	0.00	1.25	1.18	2.00	3.25	.25	6.00	0.500	1.687	5.25	3.25	7.2
TRCA16H-6		7,600														
TRCA16-12	1.000	3,280	12.00	9.00	0.25	1.25	1.18	2.00	3.25	.25	11.49	0.500	1.687	5.25	8.87	11.0
TRCA16H-12		7,600														
TRCA16-18	1.000	3,280	18.00	9.00	0.25	1.25	1.18	2.00	3.25	.25	17.49	0.500	1.687	5.25	14.87	14.0
TRCA16H-18		7,600														
TRCA16-24	1.000	3,280	24.00	9.00	0.25	1.25	1.18	2.00	3.25	.25	23.49	0.500	1.687	5.25	20.87	16.9
TRCA16H-24		7,600														
TRCA20-8	1.250	4,840	8.00	10.50	0.25	1.62	1.50	2.56	4.00	.25	7.50	0.750	2.250	6.00	3.90	16.0
TRCA20H-8		9,400														
TRCA20-12	1.250	4,840	12.00	10.50	0.25	1.62	1.50	2.56	4.00	.25	11.49	0.750	2.250	6.00	8.12	16.4
TRCA20H-12		9,400														
TRCA20-18	1.250	4,840	18.00	10.50	0.25	1.62	1.50	2.56	4.00	.25	17.49	0.750	2.250	6.00	14.12	21.6
TRCA20H-18		9,400														
TRCA20-24	1.250	4,840	24.00	10.50	0.25	1.62	1.50	2.56	4.00	.25	23.49	0.750	2.250	6.00	20.12	26.8
TRCA20H-24		9,400														
TRCA24-12	1.500	6,080	12.00	12.00	1.50	1.87	1.75	2.93	4.75	.31	9.00	1.000	2.750	6.62	5.00	30.0
TRCA24H-12		13,520														
TRCA24-18	1.500	6,080	18.00	12.00	0.25	1.87	1.75	2.93	4.75	.31	17.50	1.000	2.750	6.62	13.75	40.2
TRCA24H-18		13,520														
TRCA24-24	1.500	6,080	24.00	12.00	0.25	1.87	1.75	2.93	4.75	.31	23.50	1.000	2.750	6.62	19.75	48.1
TRCA24H-24		13,520														
TRCA24-30	1.500	6,080	30.00	12.00	0.25	1.87	1.75	2.93	4.75	.31	29.50	1.000	2.750	6.62	25.75	56.0
TRCA24H-30		13,520														
TRCA32-18	2.000	9,640	18.00	14.00	0.25	2.43	2.25	3.62	6.00	.37	17.50	1.250	3.375	7.25	12.75	61.7
TRCA32-24	2.000	9,640	24.00	14.00	0.25	2.43	2.25	3.62	6.00	.37	23.50	1.250	3.375	7.25	18.75	73.2
TRCA32-30	2.000	9,640	30.00	14.00	0.25	2.43	2.25	3.62	6.00	.37	29.50	1.250	3.375	7.25	24.75	84.8

Footnotes:

- (1) Rating based upon 2 million inches of travel with the load forces being applied downward on the linear bearing, while in a horizontal application, and based upon 1060 steel shafting (Rockwell 60C). The actual load rating, and life, is dependent upon factors detailed on pages 6 to 13.
- (2) This value is the center distance of the bearing to the top of the carriage plate surface (d_r).
- (3) This value is the center to center distance (spread) between the rails (d₁).
- (4) This value is the center to center distance (spacing) of the bearings on a single shaft (d₂).

Specifications subject to change without notice

Dimensions

(inches)

Available For:
 TRCA8-6, TRCA10-6, TRCA12-6,
 TRCA16-6, TRCA20-8, TRCA24-12

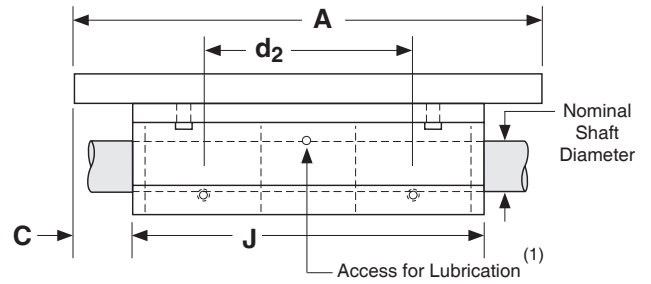
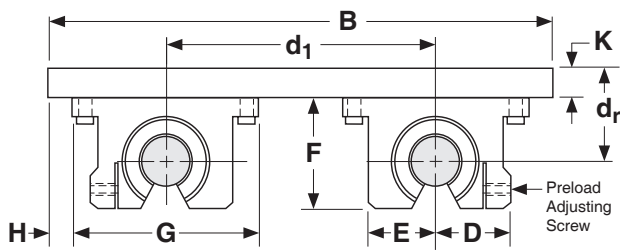

Available For:
 All other TRCA models,
 not shown above

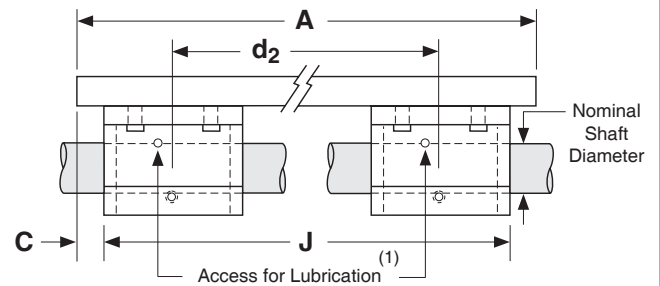
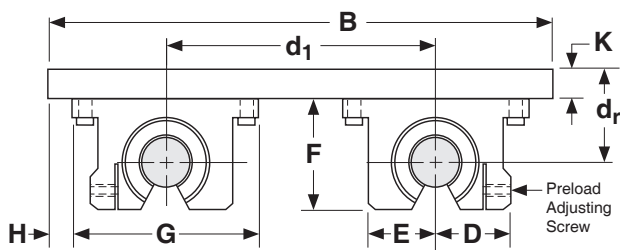

Footnotes:

(1) Size 0.500 has oil lubricant fitting. Sizes 0.625 and above have a 1/4-28 UNF straight thread access for lubrication.

(- P) Pre-Machined Carriage Mounting Holes

All carriage assembly plates are available with a pre-determined number & location of mounting holes. These holes consist of stainless steel threaded inserts per the below chart. Custom mounting patterns are available upon request.

Model Number	Carriage Length (inches)	L (inches)	Threaded Insert Size
TRCA8-6-P	6.00	5.00	#10-32
TRCA8-12-P	12.00	5.00	#10-32
TRCA8-18-P	18.00	5.00	#10-32
TRCA10-6-P	6.00	5.00	#10-32
TRCA10-12-P	12.00	5.00	#10-32
TRCA10-18-P	18.00	5.50	#10-32
TRCA12-6-P	6.00	5.00	1/4-28
TRCA12H-6-P	6.00	5.00	1/4-28
TRCA12-12-P	12.00	5.00	1/4-28
TRCA12H-12-P	12.00	5.00	1/4-28
TRCA12-18-P	18.00	5.50	1/4-28
TRCA12H-18-P	18.00	5.50	1/4-28
TRCA16-6-P	6.00	5.00	5/16-24
TRCA16H-6-P	6.00	5.00	5/16-24
TRCA16-12-P	12.00	5.00	5/16-24
TRCA16H-12-P	12.00	5.00	5/16-24
TRCA16-18-P	18.00	5.00	5/16-24
TRCA16H-18-P	18.00	5.00	5/16-24
TRCA16-24-P	24.00	5.00	5/16-24
TRCA16H-24-P	24.00	5.00	5/16-24
TRCA20-8-P	8.00	7.00	3/8-24
TRCA20H-8-P	8.00	7.00	3/8-24
TRCA20-12-P	12.00	5.00	3/8-24
TRCA20H-12-P	12.00	5.00	3/8-24
TRCA20-18-P	18.00	5.00	3/8-24
TRCA20H-18-P	18.00	5.00	3/8-24
TRCA20-24-P	24.00	5.00	3/8-24
TRCA20H-24-P	24.00	5.00	3/8-24
TRCA24-12-P	12.00	5.00	3/8-24
TRCA24H-12-P	12.00	5.00	3/8-24
TRCA24-18-P	18.00	5.00	3/8-24
TRCA24H-18-P	18.00	5.00	3/8-24
TRCA24-24-P	24.00	5.00	3/8-24
TRCA24H-24-P	24.00	5.00	3/8-24
TRCA24-30-P	30.00	5.25	3/8-24
TRCA24H-30-P	30.00	5.25	3/8-24
TRCA32-18-P	18.00	5.00	1/2-20
TRCA32-24-P	24.00	5.00	1/2-20
TRCA32-30-P	30.00	5.25	1/2-20

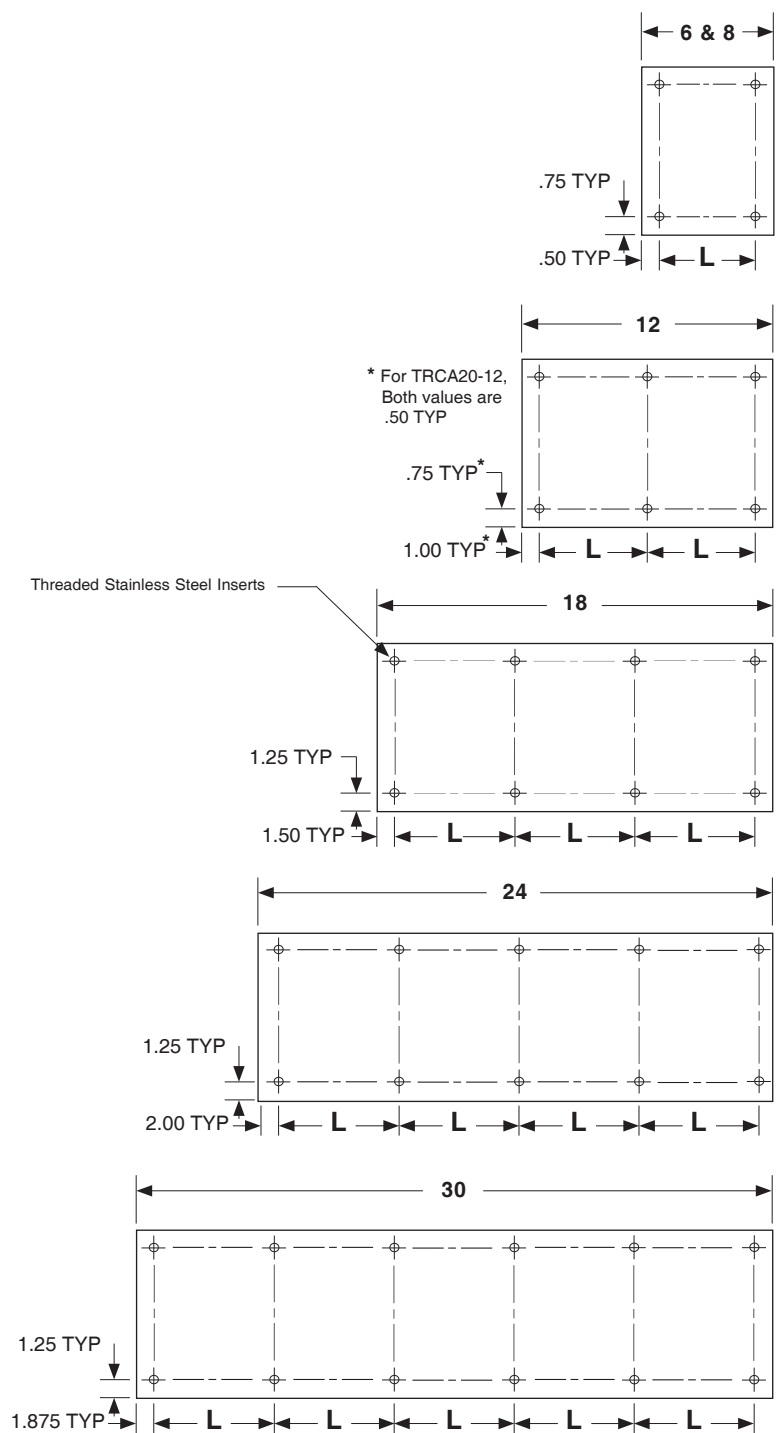

Options

(- L) Hand Wheel Lock

This option adds an aluminum clamping block to the end of a pillow block, which then provides for a manual lock of the bearing to the shaft. The threaded hand wheel shaft presses into a bronze insert which makes contact to provide a "pressure lock" to the shaft. The threaded steel screw will not back drive and does not make physical contact with the steel shaft (no steel to steel contact). The lock will be installed as shown below when ordered with a SLBC, SLBCH, SLBO, SLBOH, DLBC, DLBCH, DLBO, DLBOH, or TRCA series. Multiple locks can be installed onto a TRCA assembly.

Nominal Shaft Diameter (inches)	Dimensions (inches)						
	A	B	C	D	E		F
					open	closed	
8 - 0.500	1.680	1.72	2.00	0.50	.56	.44	2.00
10 - 0.625	1.875	1.53	2.00	0.50	.50	.31	2.50
12 - 0.750	2.067	1.46	2.00	0.50	.37	.18	2.75
16 - 1.000	2.312	1.34	2.00	0.50	.19	---	3.25
20 - 1.250	3.125	1.66	2.50	0.75	.17	---	4.00
24 - 1.500	3.625	1.46	2.50	0.75	.05	---	4.75
32 - 2.000	4.600	1.45	2.50	0.75	---	---	6.00

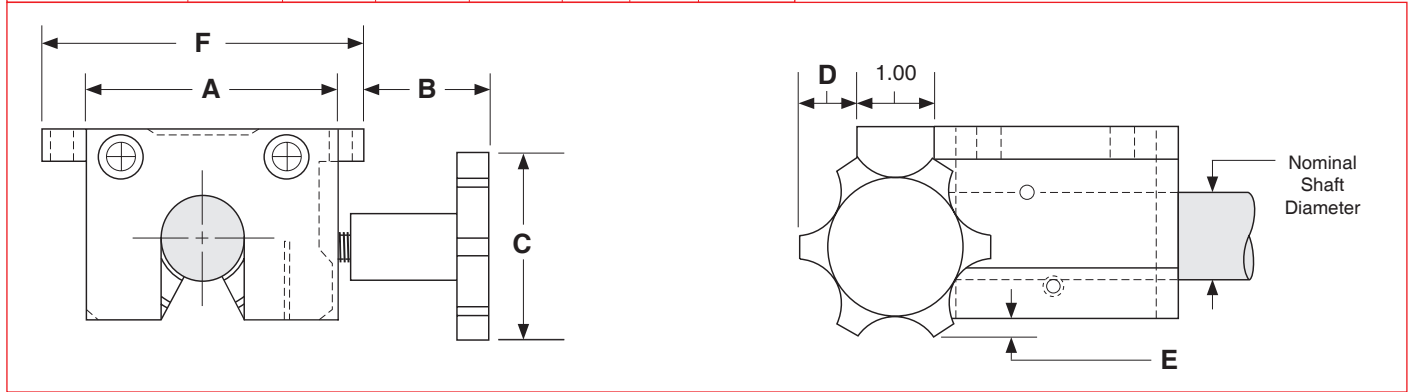

Custom Carriage Sizes

Custom carriage sizes that need to be wider, or longer than shown in this catalog can be provided upon request. This will allow for larger rail and bearing spacing (d_1 & d_2 dimensions).

Custom Carriage Material & Finishes

The standard carriage material is aluminum with a black anodized finish. Aluminum plates can be finished in many different colors, while steel carriage plates can be provided with a black oxide finish. Many other custom alternatives for carriage plates are available.

Special Grease Options

Bearings can be supplied with special greases, or lubricants, in order to meet the environmental requirements of the application. Examples of operating environments which may require a special lubricant include: high or low temperature, clean rooms, vacuums and food grade applications.

Specifications subject to change without notice

SLBCM Series

Single Self-Aligning Closed



SLBCM-A Series

Single Self-Aligning Closed Adjustable



SLBOM Series

Single Self-Aligning Open



DLBCM Series

Double Self-Aligning Closed



SLBCME Series

Single Self-Aligning Closed



SLBCME-A Series

Single Self-Aligning Closed Adjustable



SLBOME Series

Single Self-Aligning Open



SLBOME-A Series

Single Self-Aligning Open Adjustable



DLBCME Series

Double Self-Aligning Closed



DLBCME-A Series

Single Self-Aligning Closed Adjustable



DLBOME Series

Double Self-Aligning Open



DLBOME-A Series

Double Self-Aligning Open Adjustable

