

# 610 Series Positioning Tables

Introduction _____	F-2
Ordering Guide _____	F-4
Specifications _____	F-5
Dimensions _____	F-6
Mounting Brackets _____	F-9
Thrust Capacity (axial load) _____	F-11
Screw Travel Life _____	F-12
Screw Options _____	F-13
Linear Bearing Load Capacity _____	F-18
EOT & Home Switches _____	F-19
Motor Couplings _____	F-22
Motor Mount Options _____	F-24
Power-off Electric Brakes _____	F-26
Rotary Encoders _____	F-27

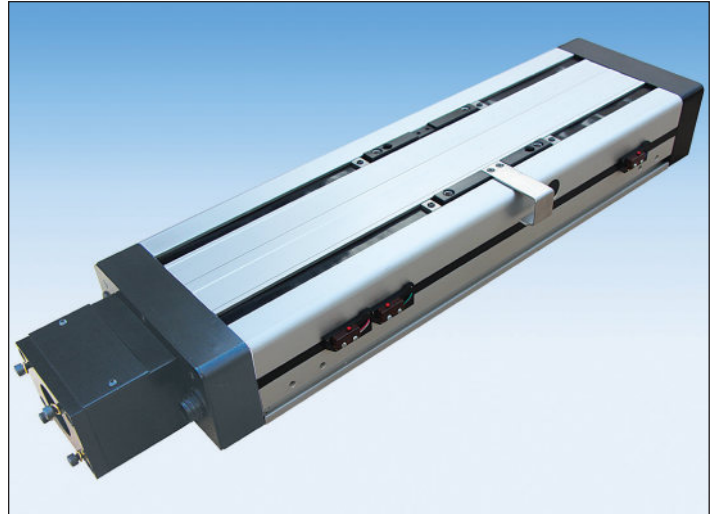

## Single or Multiple Axis

LINTECH's 610 series positioning tables offer precision performance and design flexibility for use in a wide variety of Motion Control applications.

- Welding
- Test Stands
- Part Insertion
- Laser Positioning
- Liquid Dispensing
- Semiconductor Processing
- Gluing
- Pick & Place
- Part Scanning
- Inspection Stations
- General Automation

## Quality Construction

LINTECH's 610 series tables are designed to maximize performance while minimizing physical size and cost. These tables use a low friction, preloaded, recirculating linear ball bearing system, which rides on precision ground profile linear rails. The linear rails are mounted to an aluminum base, which offers a rigid support over the entire travel of the table's carriage. The load is mounted to a precision machined aluminum carriage. The 610 series uses threaded stainless steel inserts in carriage plate for customer mounting of load. There are 38 different acme & ball screw options, that offer high efficiencies and long life at an economical price. These tables are designed to allow for numerous options. They include motor mounts, couplings, EOT & Home switches, rotary encoders, power-off electric brakes, motor wrap packages and can be configured for multiple axis applications.



## Available Options

### Acme Screws & Ball Screws

An assortment of acme screws and ball screws can be installed in the 610 series tables, providing solutions to load back driving, high duty cycle, high speed, extreme smoothness, and sensitive positioning applications.

### Carriage Adapter Plates & Cartesian Brackets

Optional carriage adapter plates and vertical angle brackets can be mounted directly to the top of various LINTECH positioning tables, thus providing for easy multiple axis configurations.

### IP30 Rated Enclosed Positioning Slide

For harsh environmental conditions, and for operator protection, these tables are fitted with aluminum covers with a belt which covers the gaps on the top where the bearing carriage rides. This provides protection for all internal components.

### End of Travel and Home Switches

The 610 series tables can be provided with end of travel (EOT) and home switches mounted and wired on either side of the table. Most position controllers can utilize the EOT switches to stop carriage motion when the extreme table travel has been reached in either direction. The home switch provides a known reference location on the table.

### Rotary Encoders

Incremental encoders can be mounted to the table in order to provide positional data back to either a motion controller, or a digital display. Contact factory if linear encoder is required.

### Motor Adapter Brackets

NEMA 23, NEMA 34, or any metric mount motor can be mounted to a 610 series positioning table with the use of adapters for interface.

### Turcite Nut With Rolled Ball Screw

This solid polymer nut has no rolling elements in it, and performs very similar to an acme nut. It can provide smoother motion & less audible noise than most ball nuts, and is ideal for corrosive & vertical applications.

### Other

The 610 series tables can be provided with **chrome plated linear bearings, rails, & screws** for corrosive environment applications, **power-off electric brakes** for load locking applications, **motor wrap packages** for space limited applications, and a **hand crank** for manually operated applications.

### Standard Features - 610 Series

- ❑ Compact 5.91 inches (150 mm) wide by 2.95 inches (75 mm) tall
- ❑ Travel lengths from 6 inches (150 mm) to 60 inches (1520 mm)
- ❑ Threaded stainless steel inserts in carriage for load mounting
- ❑ 0° F to +185° F (-18° C to +85° C) operating temperature
- ❑ 2 rails, 4 self lube bearings and 6 inch long carriage
- ❑ Precision ground profile linear rail design
- ❑ Recirculating linear ball bearing system
- ❑ IP30 rated enclosed positioning slide

### 610 Series

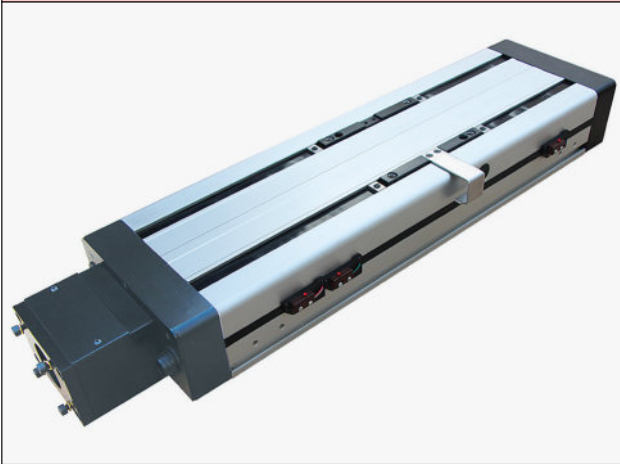

### Options - 610 Series

- ❑ Chrome plated linear bearings, rails and screws
- ❑ End of travel (EOT) and home switches wired
- ❑ CAD drawings available via our Website
- ❑ Adapter brackets for non-NEMA motors
- ❑ NEMA 23 & 34 motor wrap packages
- ❑ Rotary incremental encoders
- ❑ NEMA 34 adapter bracket
- ❑ Power-off electric brakes
- ❑ Turcite nut option
- ❑ Motor Couplings
- ❑ Ball screws:

#### Rolled - Non-preloaded & Preloaded Nuts:

0.625 inch diameter, 0.200 inch lead  
 0.625 inch diameter, 1.000 inch lead  
 0.750 inch diameter, 0.200 inch lead  
 0.750 inch diameter, 0.500 inch lead

#### Precision - Non-preloaded & Preloaded Nuts:

0.625 inch diameter, 0.200 inch lead  
 16 mm diameter, 5 mm lead  
 16 mm diameter, 10 mm lead  
 16 mm diameter, 16 mm lead  
 0.750 inch diameter, 0.200 inch lead  
 20 mm diameter, 5 mm lead  
 20 mm diameter, 20 mm lead

#### Ground - Preloaded Nuts Only:

0.625 inch diameter, 0.200 inch lead  
 0.625 inch diameter, 0.500 inch lead

- ❑ Acme screws:

#### Rolled - Non-preloaded & Preloaded Nuts:

0.625 inch diameter, 0.100 inch lead  
 0.625 inch diameter, 0.200 inch lead

**614** **6** **06** - **NE** - **TB0** - **BC0** - **1** - **S005** - **M02** - **C155** - **L01R** - **E00** - **B00**

**Table Series**

**4** - 4 bearing carriage

**Carriage Length**

**6** - 6 inches

**Travel Length** (see pages F-6 to F-7)

**06** - 6 to 60 inches

**Screw Style**

**NE** - no screw extension      **SE** - screw extension

**Tapped Mounting holes in Base** (see page F-7)

**TB0** - No holes      **TB1** - English holes      **TB2** - Metric holes

**Linear Bearing Type** (See page F-11)

**BC0** - No Ball Chain      **BC1** - With Ball Chain

**Carriage Inserts** (see page F-7)

**1** - English mount      **2** - Metric mount

**Screw Options** (see pages F-12 to F-17)

Rolled ball screws

**S005** - .625 x .200 NPL  
**S006** - .625 x .200 PL  
**S007** - .625 x .200 NPL(T)  
**S008** - .625 x .200 PL(T)  
**S009** - .625 x 1.000 NPL  
**S010** - .625 x 1.000 PL  
**S011** - .625 x 1.000 NPL(T)  
**S012** - .625 x 1.000 PL(T)  
**S013** - .750 x .200 NPL  
**S014** - .750 x .200 PL  
**S015** - .750 x .200 NPL(T)  
**S016** - .750 x .200 PL(T)

Rolled ball screws

**S017** - .750 x .500 NPL  
**S018** - .750 x .500 PL  
**S019** - .750 x .500 NPL(T)  
**S020** - .750 x .500 PL(T)

Ground ball screws

**S212** - .625 x .200 PL  
**S213** - .625 x .500 PL  
**S214** - 16 x 5 PL  
**S215** - 16 x 16 PL

Precision ball screws

**S114** - .625 x .200 NPL  
**S115** - .625 x .200 PL  
**S116** - 16 x 5 NPL  
**S117** - 16 x 5 PL  
**S118** - 16 x 10 NPL  
**S119** - 16 x 10 PL  
**S120** - 16 x 16 NPL  
**S121** - 16 x 16 PL  
**S122** - .750 x .200 NPL  
**S123** - .750 x .200 PL  
**S124** - 20 x 5 NPL  
**S125** - 20 x 5 PL  
**S128** - 20 x 20 NPL  
**S129** - 20 x 20 PL

**S999** - other

Rolled acme screws

**S300** - .625 x .100 NPL  
**S301** - .625 x .100 PL  
**S302** - .625 x .200 NPL  
**S303** - .625 x .200 PL

**Motor Mount** (see pages F-24 to F-25)

**M00** - none      **M02** - NEMA 23 mount (E)      **M06** - NEMA 23 (RH) wrap  
**M01** - hand crank      **M03** - NEMA 23 mount (M)      **M07** - NEMA 23 (LH) wrap  
**M16 to M98** - see Website      **M04** - NEMA 34 mount (E)      **M08** - NEMA 34 (RH) wrap  
**M99** - other      **M05** - NEMA 34 mount (M)      **M09** - NEMA 34 (LH) wrap

**Coupling Options** (see pages F-22 to F-23)

**C000** - none      **C025 to C030** - C100      **C130 to C136** - H100      **C407 to C415** - G100  
**C999** - other      **C048 to C069** - C125      **C155 to C184** - H131      **C435 to C464** - G126  
**C196 to C199** - H163      **C470 to C480** - G158

**Limit & Home Switches** (see pages F-19 to F-21 for location and specification)

**L00** - no switches      Mechanical      Reed      Hall      Prox (NPN)      Prox (PNP)  
**L99** - other      EOT & home switches      **L01R or L**      **L04R or L**      **L07R or L**      **L10R or L**      **L13R or L**  
EOT switches only      **L02R or L**      **L05R or L**      **L08R or L**      **L11R or L**      **L14R or L**  
home switch only      **L03R or L**      **L06R or L**      **L09R or L**      **L12R or L**      **L15R or L**

**Encoder Options - SE OPTION ONLY** (see page F-27)

**E00** - none      **E01** - rotary (500 lines/rev)      **E02** - rotary (1000 lines/rev)      **E03** - rotary (1270 lines/rev)      **E99** - other (linear or rotary)

**Power-off Brakes - SE OPTION ONLY** (see page F-26)

**B00** - none      **B01** - 24 VDC      **B02** - 90 VDC      **B99** - other

### Specifications

Load Capacities		Four (4) Bearing Carriage	
<b>Dynamic Horizontal</b>	2 million inches (50 km) of travel	7,780 lbs	( 3530 kgf)
<b>Dynamic Horizontal</b>	100 million inches (2540 km) of travel	2,090 lbs	( 948 kgf)
<b>Static Horizontal</b>		11,640 lbs	( 5280 kgf)
<b>Dynamic Roll Moment</b>	2 million inches (50 km) of travel	920 ft-lbs	( 1247 N-m)
<b>Dynamic Roll Moment</b>	100 million inches (2540 km) of travel	247 ft-lbs	( 335 N-m)
<b>Static Roll Moment</b>		1,680 ft-lbs	( 2277 N-m)
<b>Dyn. Pitch &amp; Yaw Moment</b>	2 million inches (50 km) of travel	980 ft-lbs	( 1328 N-m)
<b>Dyn. Pitch &amp; Yaw Moment</b>	100 million inches (2540 km) of travel	263 ft-lbs	( 356 N-m)
<b>Static Pitch &amp; Yaw Moment</b>		1,770 ft-lbs	( 2400 N-m)
<b>Each Bearing Dyn. Capacity</b>	2 million inches (50 km) of travel	1,945 lbs	( 882 kgf)
<b>Each Bearing Dyn. Capacity</b>	100 million inches (2540 km) of travel	525 lbs	( 238 kgf)
<b>Each Bearing Static Load Capacity</b>		2,910 lbs	( 1320 kgf)
<b>Thrust Force Capacity</b>	10 million screw revolutions	895 lbs	( 406 kgf)
<b>Thrust Force Capacity</b>	500 million screw revolutions	240 lbs	( 109 kgf)
<b>Maximum Acceleration</b>		772 in/sec <sup>2</sup>	( 19,6 m/sec <sup>2</sup> )
<b>d<sub>1</sub></b>	Center to center distance (spread) between the two rails	3.228 in	( 81,99 mm)
<b>d<sub>2</sub></b>	Center to center distance (spacing) of the bearings on a single rail	3.476 in	( 88,29 mm)
<b>d<sub>r</sub></b>	Center distance of the bearing to top of carriage plate surface	1.299 in	( 32,99 mm)

Other	Four (4) Bearing Carriages
<b>Table Material</b>	Base, Carriage, End Plates & Cover Plate Option - 6061 anodized aluminum
<b>Linear Rail Material</b>	Case Hardened Steel
<b>Screw Material</b> (see pages F-13 to F16)	Acme Screw - Stainless Steel
<b>Screw Material</b> (see pages F-13 to F16)	Rolled Ball, Precision Ball, & Ground Ball - Case Hardened Steel
<b>Unidirectional Repeatability</b>	+/- 0.0002 in (5 microns)
<b>Bidirectional Repeatability</b>	+/- 0.0002 in (5 microns) to +/- 0.0082 in (208 microns) - depends on selected screw
<b>Straightness</b>	< 0.00016 in/in (< 4,06 microns/25mm)
<b>Flatness</b>	< 0.00016 in/in (< 4,06 microns/25mm)
<b>Orthogonality</b> (multi-axis systems)	< 30 arc-seconds
<b>Friction Coefficient</b>	< 0.01
<b>Motor Mount</b>	NEMA 23 & 34 Mounts, Metric Mounts, Motor Wraps, and Hand Crank Option
<b>Coupling</b>	Three (3) different styles available
<b>Belt Cover Strip Material</b>	Black - Polyurethane

Specifications subject to change without notice

### Dimensions & Specifications

Model Number	Travel Length inches (mm)	Table Dimensions inches (mm)		Mounting Dimensions inches (mm)					Screw Length inches (mm)	Table <sup>(2)</sup> Weight lbs (kgf)
		A	B	C	D	E	M <sup>(1)</sup>	N		
<b>614606-NE</b>	6 (150)	12.125 (308,0)	17.800 (452,1)	10.125 (257,18)	8.125 (206,38)	3	8	8	13.40 (340)	18.3 (8,3)
<b>614612-NE</b>	12 (300)	18.125 (460,4)	23.800 (604,5)	16.125 (409,58)	14.125 (358,78)	5	8	12	19.40 (493)	23.5 (10,7)
<b>614618-NE</b>	18 (455)	24.125 (612,8)	29.800 (756,9)	22.125 (561,98)	20.125 (511,18)	7	8	16	25.40 (645)	28.7 (13,0)
<b>614624-NE</b>	24 (605)	30.125 (765,2)	35.800 (909,3)	28.125 (714,38)	12.563 (319,10)	9	12	20	31.40 (798)	34.0 (15,4)
<b>614630-NE</b>	30 (760)	36.125 (917,6)	41.800 (1061,7)	34.125 (866,78)	15.563 (395,30)	11	12	24	37.40 (950)	39.3 (17,8)
<b>614636-NE</b>	36 (910)	42.125 (1070,0)	47.800 (1214,1)	40.125 (1019,18)	18.563 (471,50)	13	12	28	43.40 (1102)	44.6 (20,2)
<b>614642-NE</b>	42 (1060)	48.125 (1222,4)	53.800 (1366,5)	46.125 (1171,58)	21.563 (547,70)	15	12	32	49.40 (1255)	49.8 (22,6)
<b>614648-NE</b>	48 (1215)	54.125 (1374,8)	59.800 (1518,9)	52.125 (1323,98)	16.042 (407,47)	17	16	36	55.40 (1407)	55.1 (25,0)
<b>614654-NE</b>	54 (1370)	60.125 (1527,1)	65.800 (1671,3)	58.125 (1476,38)	18.042 (458,27)	19	16	40	61.4 (1560)	60.4 (27,4)
<b>614660-NE</b>	60 (1520)	66.125 (1679,6)	71.800 (1823,7)	64.125 (1628,78)	20.042 (509,07)	21	16	44	67.4 (1712)	65.7 (29,8)

└ 4; Carriage has 4 bearings; Carriage weight = 3.0 lbs (1,36 kg)

#### Footnotes:

- (1) Mounting holes are total number. These holes are used for vertically mounting using 212790 "L" bracket. See page F-9 for details on bracket.
- (2) Weight shown is with a 0.625 inch (16 mm) diameter screw, a NEMA 23 motor mount [0.42 lbs (0,19 kg)], a C100 style [0.09 lbs (0,04 kg)] coupling, and a 4 bearing carriage. When using a 0.750 inch (20 mm) diameter screw add 0.042 lbs per inch (0,00075 kg per mm) of screw length for a given model number.

Dimensions - NE and SE

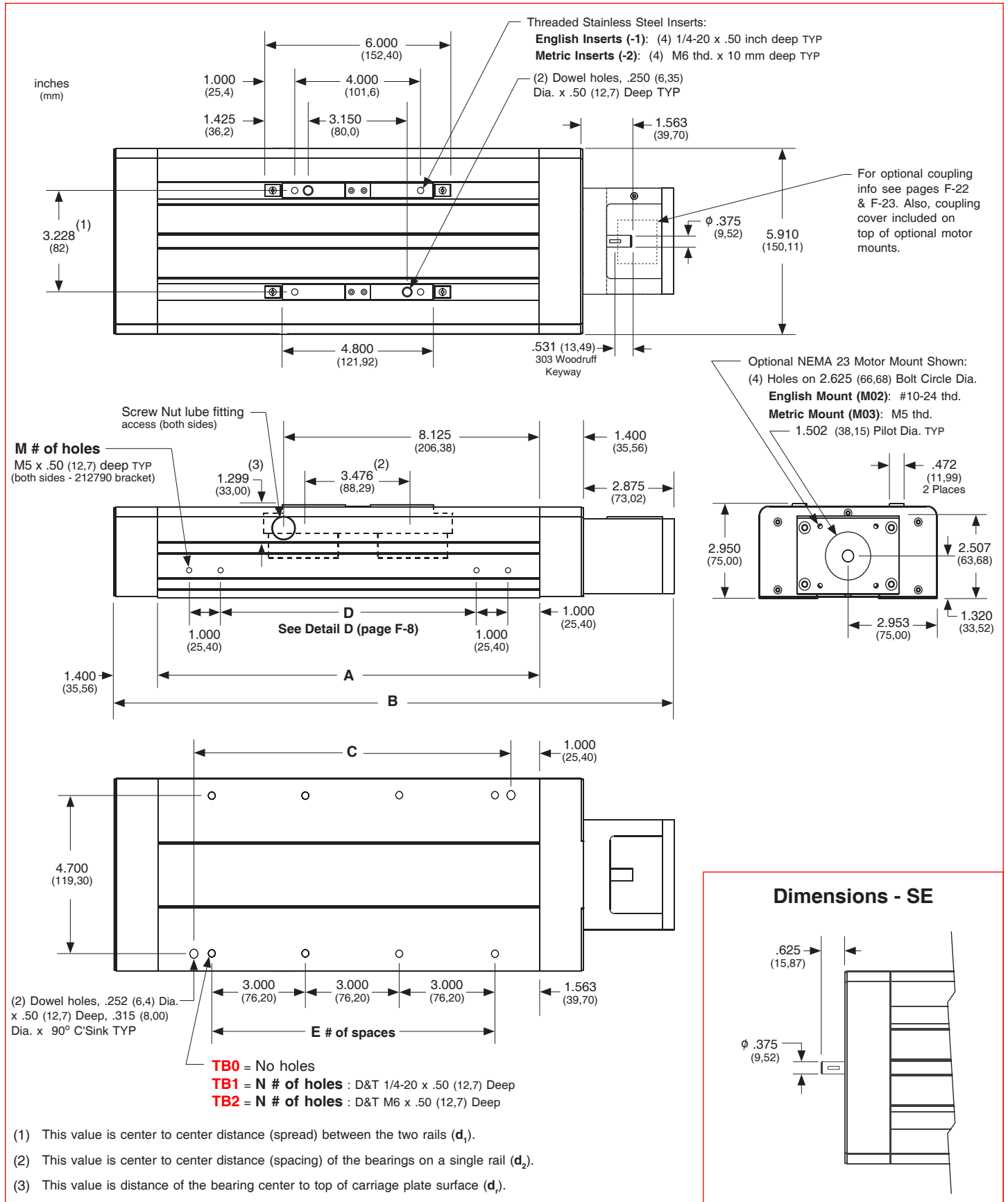

**Note:** Any 610 series can be mounted on top of a second 610 series table, in order to create X-Y multiple axis configurations. See page F-10 for optional 213320 carriage adapter plate information.

Specifications subject to change without notice



## Dimensions - Detail D

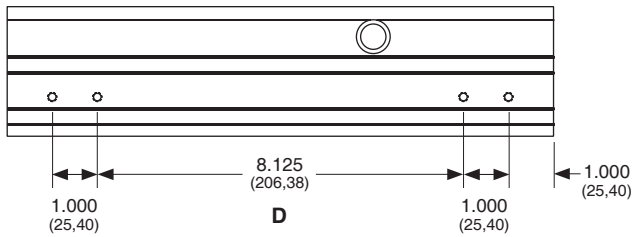

**6" travel**

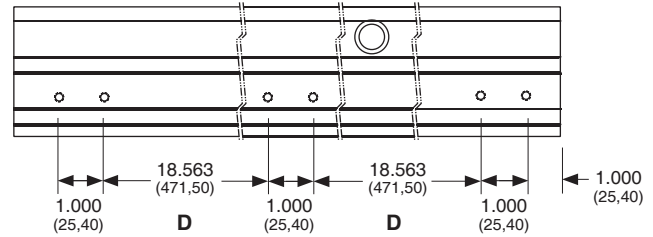

**36" travel**

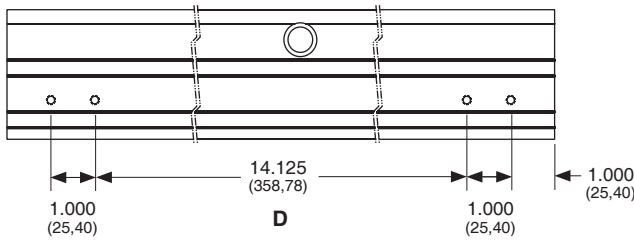

**12" travel**

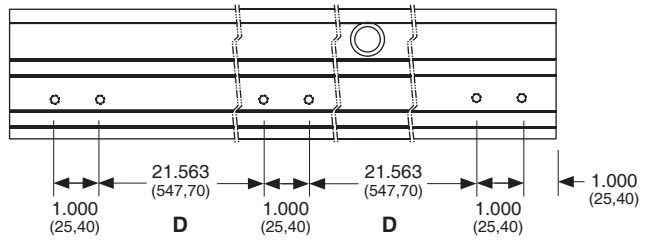

**42" travel**

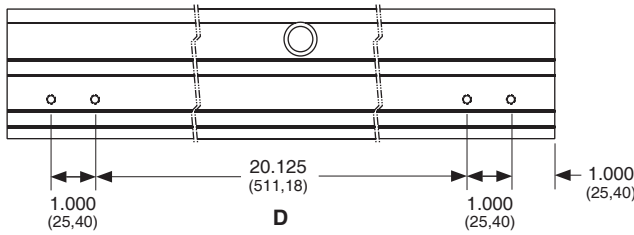

**18" travel**

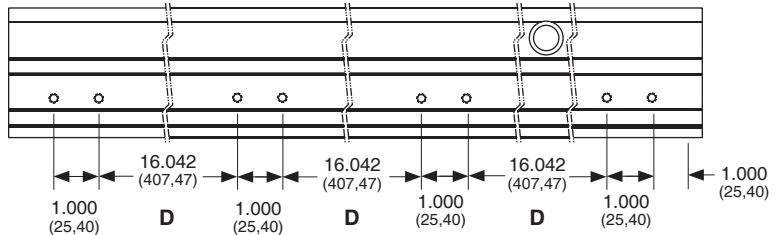

**48" travel**

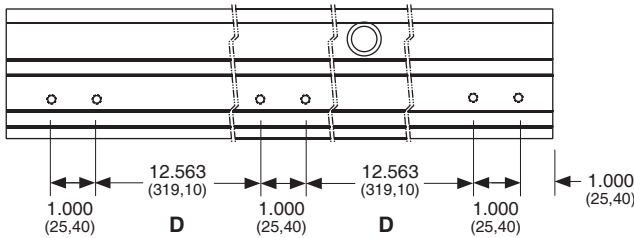

**24" travel**

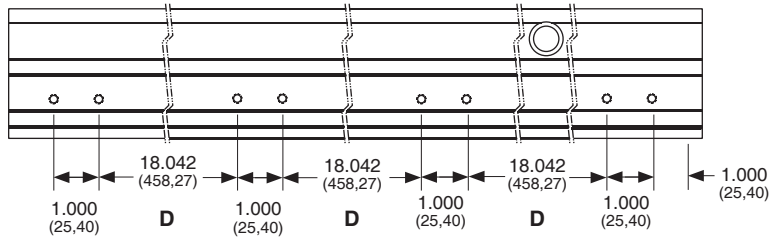

**54" travel**

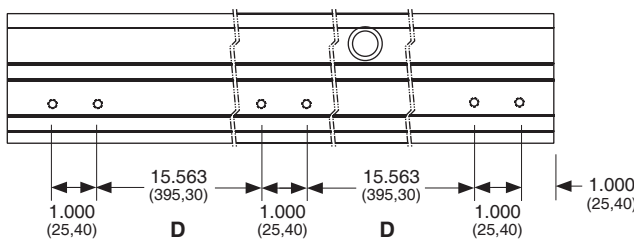

**30" travel**

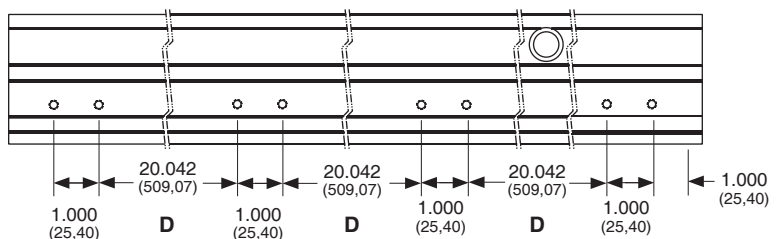

**60" travel**



Mounting Brackets

Mounting brackets (or tapped base holes see page F-7) are required in order to install the 610 onto a horizontal or vertical surface. Two bracket styles allow for ease of installation. The horizontal bracket uses the 610 extrusion slot on both sides to rigidly hold the unit. The vertical bracket uses drilled & tapped holes on the extrusion body on both sides. This provides a fixed and safer means of holding the unit when installed vertically.

Horizontal Mount Bracket (part # 208777)	Vertical Mount Bracket (part # 212790)
<p>Material Aluminum</p>	<p>Material Aluminum</p>
<p>Weight 0.40 lbs (0.18 kgf)</p>	<p>Weight 0.09 lbs (0.04 kgf)</p>

Moment of Inertia Values

The "moment of inertia" of an object is a gauge of the strength of that object to resist deflecting when used in an application or orientation where deflection might occur. The higher an I value relates to a lower amount of deflection.

$I = 3.75 \text{ in}^4 \text{ (} 15.60 \times 10^5 \text{ mm}^4\text{)}$

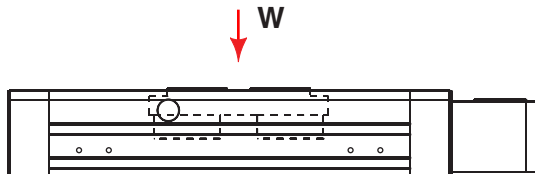

$I = 23.84 \text{ in}^4 \text{ (} 99.23 \times 10^5 \text{ mm}^4\text{)}$

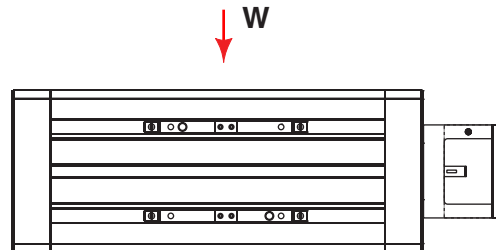

Specifications subject to change without notice

**X-Y Bracket**

Mounting bracket is required in order to install the 610 onto a horizontal or vertical surface in a "stacked" X-Y configuration. This X-Y adapter plate is used to mount a 610 unit onto a second 610 unit in a configuration.

**X-Y Adapter Plate**  
213320

**Material**  
Aluminum

**Weight**  
3.90 lbs  
(1.77 kgf)

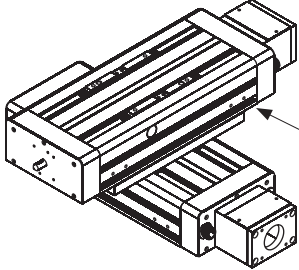

Note: (4) tapped holes and (2) dowel pin holes are required in the base of the upper axis in order to use this adapter plate

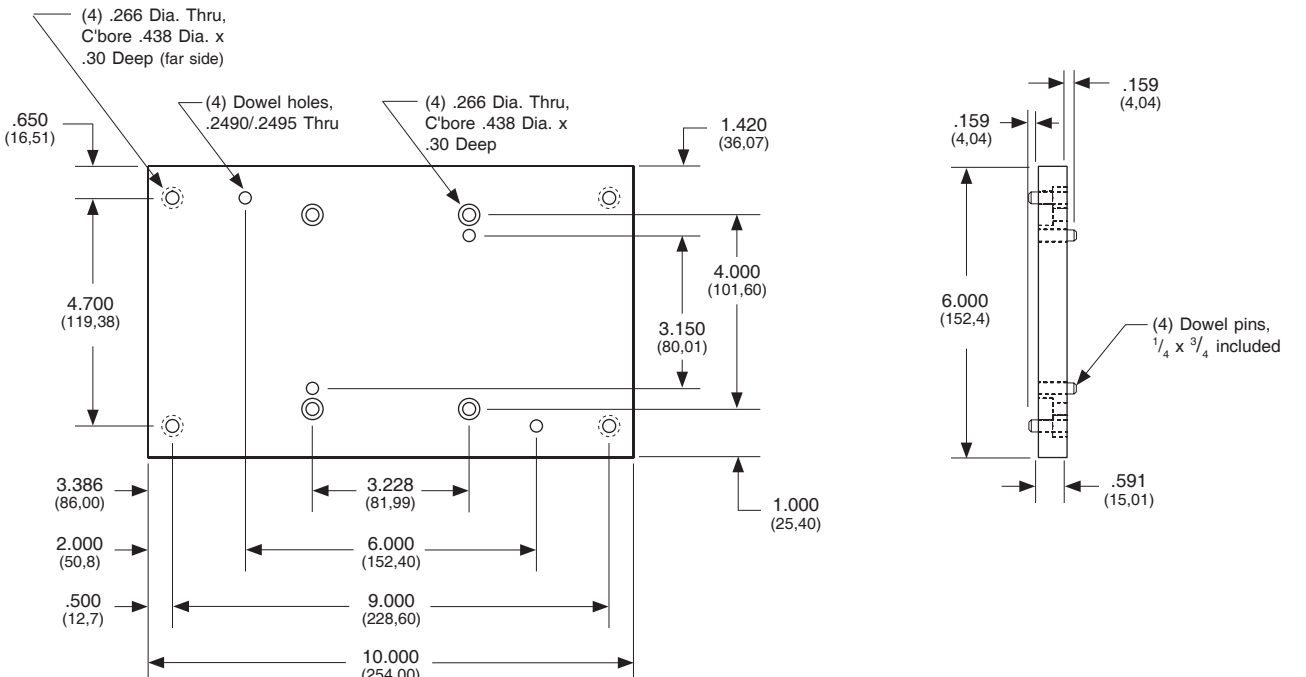

(4) .266 Dia. Thru, C'bore .438 Dia. x .30 Deep (far side)

(4) Dowel holes, .2490/.2495 Thru

(4) .266 Dia. Thru, C'bore .438 Dia. x .30 Deep

.650 (16,51)

4.700 (119,38)

3.150 (80,01)

4.000 (101,60)

1.420 (36,07)

3.386 (86,00)

2.000 (50,8)

.500 (12,7)

3.228 (81,99)

6.000 (152,40)

9.000 (228,60)

10.000 (254,00)

1.000 (25,40)

.159 (4,04)

.159 (4,04)

6.000 (152,4)

(4) Dowel pins, 1/4 x 3/4 included

.591 (15,01)

**Screw Nut Lubrication Access**

Screw nut lube access is provided on both sides of the base. Lubrication can be input into any of the optional screw nuts via an Alemite 1885 fitting inserted into the carriage. This fitting is accessible on each side by removing the round black extrusion cover on the side of the 610 base. The location is dimensioned on page F-7. Only one side insertion is required.

**Screw Lube Fitting**

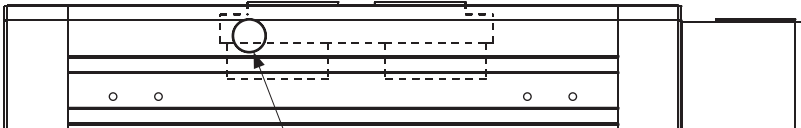

Screw nut lube fitting access (both sides) use LinTech 45221 adapter for "grease gun"

**part # 45221**



1/8 NPTF. Mates with "grease gun"

**Ball Chain Option for Bearings (-BC1)**

The 610 series utilizes self lube profile rail linear bearings with re-circulating steel balls. The ball chain option captures each steel ball preventing any contact from one ball to another, as the balls re-circulate. This allows for increased linear velocity, acceleration, and provides for longer life as well. In addition, this feature will reduce the "audible noise" for the re-circulating balls, and increase the smoothness of motion. .

**Thrust Capacity (axial load)**

The life of the screw end support bearings can be estimated by evaluating the applied axial (thrust) load. The applied load "as seen by the bearings" depends upon the table orientation. Typically, the extra force acting upon the bearings during the acceleration interval is offset by a reduction in force during the deceleration interval. Therefore, evaluating the life of the bearings at a constant speed is adequate. The life of the screw end support bearings may not be the limiting element for a given application. See page for load/life capacity of acme and ball screw nuts.

$$L = \left[ \frac{R}{F \times S} \right]^3 \times B$$

- B** = 2 (for millions of revolutions)
- E** = externally applied extra forces
- F** = applied axial load (*as seen by the bearings*)
- L** = calculated life (millions of revolutions)
- R** = dynamic load capacity of bearings at 2 million screw revolutions (see below)
- S** = safety factor (1 to 8)
- W** = user mounted load weight to carriage
- μ** = coefficient of friction for linear bearing system (0.01)

Horizontal Application

$$F = (W \times \mu) + E$$

Vertical Application

$$F = W + E$$

Screw End Supports		Number of Screw Revolutions millions of screw revolutions						
		Static	1	2	10	50	100	500
<b>Thrust Capacity</b>	lbs (kg)	1,725 (782)	1,725 (782)	1,530 (694)	895 (406)	525 (238)	415 (188)	240 (109)

Note: Multiply screw revolutions by the screw lead in order to convert to inches (or mm) traveled by the nut.

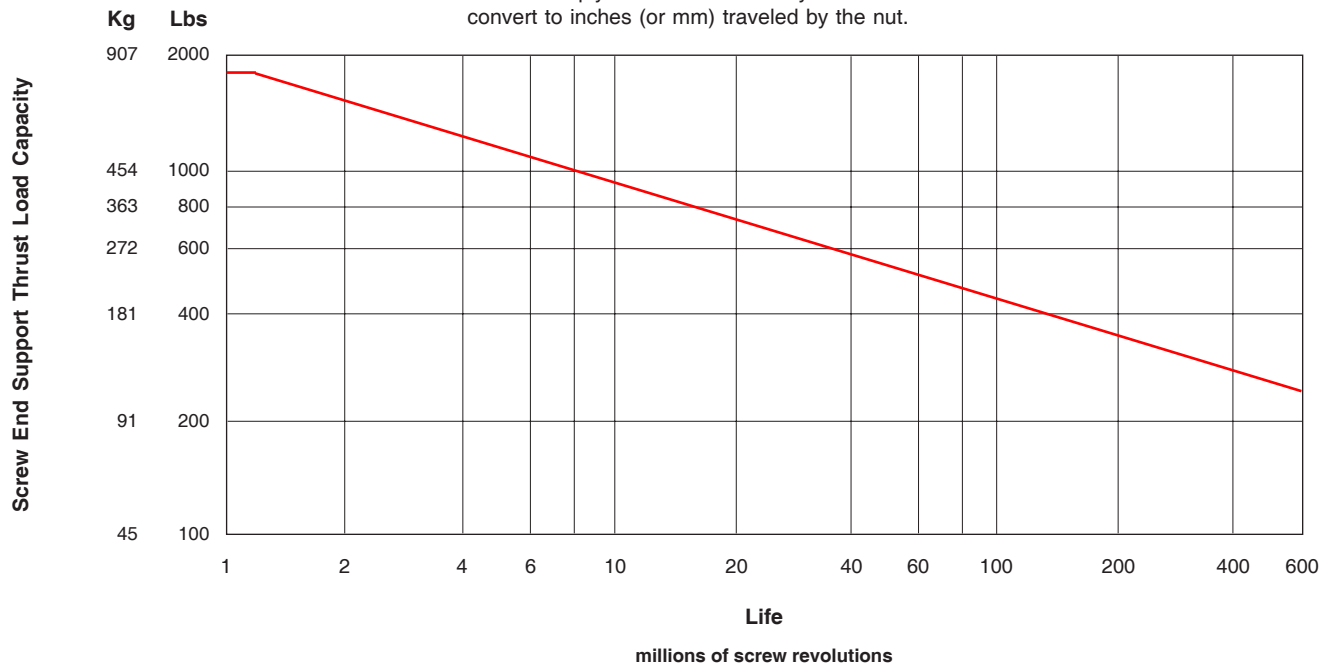

Specifications subject to change without notice

Screw Travel Life

The life of an acme or ball screw can be estimated by evaluating the load applied to the nut. The applied load "as seen by the screw nut" depends upon the table orientation. Typically, the extra force acting upon the screw nut during the acceleration interval is offset by a reduction in force during the deceleration interval. Therefore, evaluating the life of the screw nut at a constant speed is adequate. The life of the screw nut may not be the limiting element for a given application. See page for load/life capacity of the screw end support bearings.

$$L = \left[ \frac{R}{F \times S} \right]^3 \times B$$

- B** = either 1 (for millions of inches) or 25 (for Km)
- E** = externally applied extra forces
- F** = applied axial load (*as seen by screw nut*)
- L** = calculated travel life (millions of inches or Km)
- R** = rated dynamic load capacity of screw nut at 1 million inches of travel or 25 Km (see pages )
- S** = safety factor (1 to 8)
- W** = user mounted load weight to carriage
- $\mu$  = coefficient of friction for linear bearing system (0.01)

Horizontal Application

$$F = (W \times \mu) + E$$

Vertical Application

$$F = W + E$$

**Note:** Multiply values derived from graph below by 0.90 to obtain the life for a preloaded nut assembly.

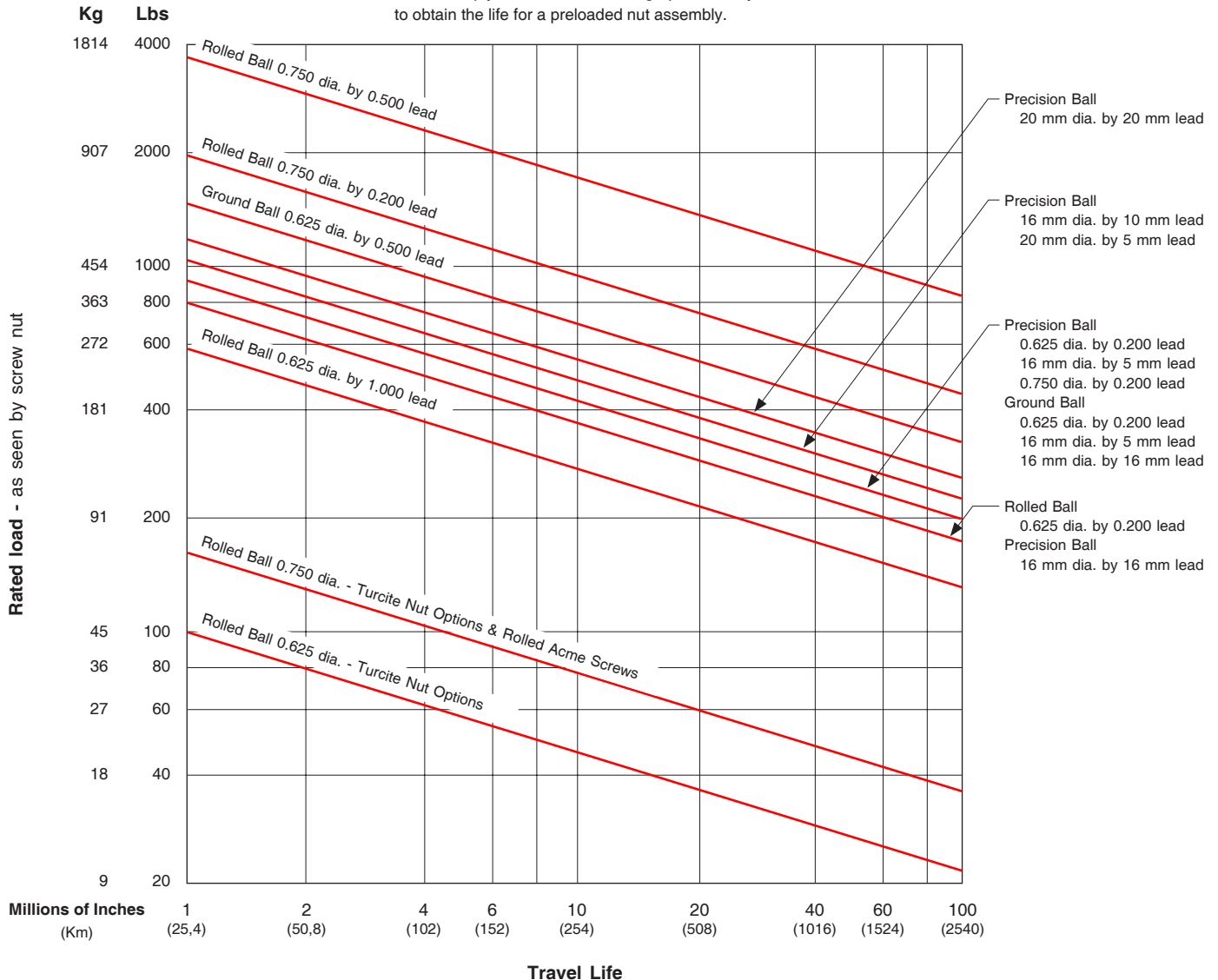

Specifications subject to change without notice

## Screws - Acme &amp; Ball

Acme screws use a turcite (polymer), or bronze nut. The nut threads ride in the matching acme screw threads, much like the ordinary nut and bolt system. This produces a higher friction (lower efficiency) system than a ball screw assembly, since there are no rolling elements between the nut and the acme screw threads. For applications requiring low speeds, noise and duty cycles, an acme screw works fine. Also, an acme screw is a good choice for most vertical applications, as it typically prevents back driving of the attached load.

Ball screws are the screw of choice for high duty cycle, high speed, and long life applications. The 610 series tables can be fitted with an assortment of ball screws. The ball screw nut uses one or more circuits of recirculating steel balls which roll between the nut and ball screw grooves, providing an efficient low friction system. Using a higher lead

ball screw (for example a 0.500 inch lead instead of a 0.200 inch lead) will offer greater carriage speed for applications requiring rapid traverse, or fast, short incremental moves. Low wear and long life are key features of a ball screw system.

*LINTECH* provides three different ball screw configurations. The rolled ball screw system utilizes a tapped nut with a standard accuracy grade rolled screw. The precision ball screw system utilizes a ground nut with a higher accuracy grade rolled screw. The ground ball screw system utilizes a ground nut with a high accuracy precision ground screw.

Some screws are available with preloaded nuts. The preloaded nut assembly offers high *bidirectional* repeatability by eliminating backlash.

Consideration	Acme Screw	Ball Screws			Comments
		Rolled	Precision	Ground	
<b>Audible noise</b>	least audible noise	most audible noise	less audible noise than rolled screw	less audible noise than precision screw	<b>Acme:</b> no rolling elements provide for quiet operation. <b>Ball:</b> recirculating balls in nut assembly transmit audible noise during motion; due to more accurate machining procedures - precision & ground ball screws are quieter than rolled ball screws.
<b>Back Driving Loads</b>	may prevent back driving	can easily back drive a load	can easily back drive a load	can easily back drive a load	<b>Acme:</b> good for light loads & vertical applications. <b>Ball:</b> recirculating balls in nut assembly produce a low friction system; vertical applications may require a brake to hold the load when no power is applied to the motor.
<b>Backlash non-preloaded nut</b>	will increase with wear	constant	constant	constant	<b>Acme:</b> preloaded nut assembly eliminates backlash. <b>Ball:</b> preloaded nut assembly eliminates backlash.
<b>Duty Cycle</b>	low to medium (< 50 %)	high (100 %)	high (100 %)	high (100 %)	<b>Acme:</b> low duty cycle due to high sliding friction. <b>Ball:</b> high duty cycle due to recirculating balls in nut assembly; high efficiency & low friction system.
<b>Life</b>	shorter due to higher friction	long	long	long	<b>Acme:</b> mechanical wear related to duty cycle, load & speed. <b>Ball:</b> minimal wear if operated in proper environment, within load specifications, and periodically lubricated.
<b>Relative - Cost</b>	slightly more than rolled ball	least expensive	slightly more than rolled ball	most expensive	<b>Acme:</b> a little more expensive than the rolled ball screw. <b>Ball:</b> due to more accurate manufacturing procedures precision rolled & ground ball screws are more expensive.
<b>Screw Efficiency</b>	low 40 % -Acme 60 % -Turcite	high (90 %)	high (90 %)	high (90 %)	<b>Acme:</b> low efficiency due to high sliding friction. <b>Ball:</b> high efficiency due to recirculating balls in nut assembly - low friction system.
<b>Smoothness</b>	can be smooth	least smooth	medium smoothness	smoothest	<b>Acme:</b> due to friction can start/stop at very low speeds. <b>Ball:</b> smoothness is constant through a wide speed range; due to more accurate manufacturing procedures precision rolled & ground ball screws are smoother than rolled ball screws.
<b>Speeds</b>	low	high	high	high	<b>Acme:</b> high friction can causes excess heat & wear at high speeds. <b>Ball:</b> recirculating balls in nut provide for a high speed system due to low friction & high efficiency.

Specifications subject to change without notice

## Screws - Acme &amp; Ball

Model Number	Travel Length in (mm)	Maximum Safe Table Operating Speed <sup>(1)</sup>										
		in/sec (mm/sec)										
		Screw										
		0.625 dia. 0.100 lead	0.625 dia. 0.200 lead	0.625 dia. 0.500 lead	0.625 dia. 1.000 lead	16 mm dia. 5 mm lead	16 mm dia. 10 mm lead	16 mm dia. 16 mm lead	0.750 dia. 0.200 lead	0.750 dia. 0.500 lead	20 mm dia. 5 mm lead	20 mm dia. 20 mm lead
614606	6 (150)	5.0 (127)	10.0 (254)	25.0 (635)	50.0 (1270)	9.8 (249)	19.7 (500)	31.5 (800)	10.0 (254)	25.0 (635)	9.8 (249)	39.3 (998)
614612	12 (300)	5.0 (127)	10.0 (254)	25.0 (635)	50.0 (1270)	9.8 (249)	19.7 (500)	31.5 (800)	10.0 (254)	25.0 (635)	9.8 (249)	39.3 (998)
614618	18 (455)	5.0 (127)	10.0 (254)	25.0 (635)	50.0 (1270)	9.8 (249)	19.7 (500)	31.5 (800)	10.0 (254)	25.0 (635)	9.8 (249)	39.3 (998)
614624	24 (605)	5.0 (127)	10.0 (254)	25.0 (635)	50.0 (1270)	9.8 (249)	19.7 (500)	31.5 (800)	10.0 (254)	25.0 (635)	9.8 (249)	39.3 (998)
614630	30 (760)	4.6 (117)	9.3 (236)	24.0 (609)	47.7 (1211)	9.5 (241)	18.8 (447)	30.4 (772)	10.0 (254)	25.0 (635)	9.8 (249)	39.3 (998)
614636	36 (910)	3.4 (86)	6.9 (175)	17.8 (452)	35.4 (899)	7.0 (177)	13.9 (353)	22.5 (571)	8.8 (223)	21.6 (548)	8.9 (226)	35.9 (912)
614642	42 (1060)	2.6 (66)	5.3 (134)	13.7 (348)	27.3 (693)	5.4 (137)	10.7 (272)	17.4 (441)	6.7 (170)	16.6 (421)	6.9 (175)	27.7 (703)
614648	48 (1215)	2.1 (53)	4.2 (106)	10.9 (276)	21.7 (551)	4.3 (109)	8.5 (216)	13.8 (350)	5.3 (134)	13.2 (335)	5.4 (137)	22.0 (558)
614654	54 (1370)	1.7 (43)	3.4 (86)	8.8 (224)	17.6 (447)	3.5 (89)	6.9 (175)	11.2 (284)	4.3 (109)	10.7 (271)	4.4 (111)	17.9 (455)
614660	60 (1520)	1.4 (35)	2.8 (71)	7.3 (185)	14.6 (370)	2.9 (73)	5.7 (145)	9.3 (236)	3.6 (91)	8.9 (226)	3.7 (94)	14.8 (376)

## Footnotes:

(1) These listed speeds are a mechanical limitation. The maximum speed of a positioning table depends on the screw diameter, screw lead, screw length, and the screw end bearing support configuration. *LINTECH* uses a rigid-rigid screw end bearing support configuration in its positioning tables. The correct motor & drive system needs to be selected in order to obtain the above maximum table speeds.

## Screws - Acme &amp; Ball

SCREW	ROLLED BALL SCREWS							
	Dyn. <sup>(1)</sup> Capacity lbs (kg)	Static Capacity lbs (kg)	Screw Efficiency %	Breakaway Torque oz-in (N-m)	Position Accuracy inch/ft (microns/300 mm)	Backlash inches (microns)	Unidirectional Repeatability inches (microns)	Bidirectional Repeatability inches (microns)
0.625 inch dia. 0.200 inch lead	<i>Non-preloaded</i> (S005)	800 (363)	6,150 (2790)	90	10 (0,07)	< 0.003 (75)	< 0.008 (203)	+ 0.0002 to - 0.0002 (5)
	<i>Preloaded</i> (S006)	720 (326)	6,070 (2753)		20 (0,14)			
	<i>Non-preloaded</i> Turcite Nut (S007)	100 (45)	800 (363)	60	15 (0,11)	< 0.008 (203)	+ 0.0002 to - 0.0082 (5)	
	<i>Preloaded</i> Turcite Nut (S008)	90 (41)	800 (363)		30 (0,21)	0		+ 0.0002 to - 0.0002 (5)
0.625 inch dia. 1.000 inch lead	<i>Non-preloaded</i> (S009)	590 (267)	2,425 (1100)	90	25 (0,18)	< 0.004 (100)	< 0.008 (203)	+ 0.0002 to - 0.0082 (5)
	<i>Preloaded</i> (S010)	530 (240)	2,390 (1084)		40 (0,28)			
	<i>Non-preloaded</i> Turcite Nut (S011)	100 (45)	800 (363)	60	35 (0,25)	< 0.008 (203)	+ 0.0002 to - 0.0082 (5)	
	<i>Preloaded</i> Turcite Nut (S012)	90 (41)	800 (363)		60 (0,42)	0		+ 0.0002 to - 0.0002 (5)
0.750 inch dia. 0.200 inch lead	<i>Non-preloaded</i> (S013)	1,900 (862)	18,800 (8527)	90	20 (0,14)	< 0.003 (75)	< 0.008 (203)	+ 0.0002 to - 0.0082 (5)
	<sup>(2)</sup> <i>Preloaded</i> (S014)	1,710 (776)	18,610 (8441)		30 (0,21)			
	<i>Non-preloaded</i> Turcite Nut (S015)	195 (88)	1,500 (680)	60	25 (0,18)	< 0.008 (203)	+ 0.0002 to - 0.0082 (5)	
	<i>Preloaded</i> Turcite Nut (S016)	175 (79)	1,500 (680)		40 (0,28)	0		+ 0.0002 to - 0.0002 (5)
0.750 inch dia. 0.5000 inch lead	<i>Non-preloaded</i> (S017)	3,450 (1565)	24,200 (10977)	90	25 (0,18)	< 0.003 (75)	< 0.008 (203)	+ 0.0002 to - 0.0082 (5)
	<sup>(2)</sup> <i>Preloaded</i> (S018)	3,150 (1429)	23,855 (10820)		40 (0,28)			
	<i>Non-preloaded</i> Turcite Nut (S019)	195 (88)	1,500 (680)	60	35 (0,25)	< 0.008 (203)	+ 0.0002 to - 0.0082 (5)	
	<i>Preloaded</i> Turcite Nut (S020)	175 (79)	1,500 (680)		60 (0,42)	0		+ 0.0002 to - 0.0002 (5)

## Footnotes:

- (1) Dynamic load capacity of screw based on 1 million inches of travel (25Km).
- (2) There is a 0.675 inch (17,1 mm) reduction of carriage travel (from the listed travel) when using a preloaded nut with this screw option for all (-CP0), (-CP1), and (-CP2) model versions with a 6 inch carriage. All the model numbers with (-WC1) and 12 inch carriages are not affected.



## Screws - Acme &amp; Ball

SCREW		PRECISION BALL SCREWS							Bidirectional Repeatability inches (microns)	
		Dyn. <sup>(1)</sup> Capacity lbs (kg)	Static Capacity lbs (kg)	Screw Efficiency %	Breakaway Torque oz-in (N-m)	Position Accuracy inch/ft (microns/300 mm)	Backlash inches (microns)	Unidirectional Repeatability inches (microns)		
0.625 inch dia. 0.200 inch lead	<i>Non-preloaded</i> (S114)	876 (397)	2,700 (1224)	90	10 (0,07)	< 0.002 (50)	< 0.003 (76)	+/- 0.0002 (5)	+ 0.0002 to - 0.0032 (5) (81)	
	<i>Preloaded</i> (S115)	788 (357)	2,430 (1102)		20 (0,14)		0		+ 0.0002 to - 0.0002 (5) (5)	
16 mm dia. 5 mm lead	<i>Non-preloaded</i> (S116)	876 (397)	2,700 (1224)	90	10 (0,07)	< 0.002 (50)	< 0.003 (76)	+/- 0.0002 (5)	+ 0.0002 to - 0.0032 (5) (81)	
	<i>Preloaded</i> (S117)	788 (357)	2,430 (1102)		20 (0,14)		0		+ 0.0002 to - 0.0002 (5) (5)	
16 mm dia. 10 mm lead	<i>Non-preloaded</i> (S118)	1,080 (489)	2,630 (1192)	90	15 (0,11)	< 0.002 (50)	< 0.003 (76)	+/- 0.0002 (5)	+ 0.0002 to - 0.0032 (5) (81)	
	<i>Preloaded</i> (S119)	972 (440)	2,365 (1072)		25 (0,18)		0		+ 0.0002 to - 0.0002 (5) (5)	
16 mm dia. 16 mm lead	<i>Non-preloaded</i> (S120)	819 (371)	1,620 (734)	90	20 (0,14)	< 0.002 (50)	< 0.003 (76)	+/- 0.0002 (5)	+ 0.0002 to - 0.0032 (5) (81)	
	<i>Preloaded</i> (S121)	737 (334)	1,455 (659)		35 (0,24)		0		+ 0.0002 to - 0.0002 (5) (5)	
0.750 inch dia. 0.200 inch lead	<i>Non-preloaded</i> (S122)	964 (437)	3,360 (1524)	90	15 (0,11)	< 0.002 (50)	< 0.003 (76)	+/- 0.0002 (5)	+ 0.0002 to - 0.0032 (5) (81)	
	<i>Preloaded</i> (S123)	867 (393)	3,025 (1372)		25 (0,18)		0		+ 0.0002 to - 0.0002 (5) (5)	
20 mm dia. 5 mm lead	<i>Non-preloaded</i> (S124)	1,070 (485)	3,990 (1809)	90	15 (0,11)	< 0.002 (50)	< 0.003 (76)	+/- 0.0002 (5)	+ 0.0002 to - 0.0032 (5) (81)	
	<i>Preloaded</i> (S125)	960 (435)	3,590 (1628)		25 (0,18)		0		+ 0.0002 to - 0.0002 (5) (5)	
20 mm dia. 20 mm lead	<i>Non-preloaded</i> (S128)	1,293 (586)	3,505 (1589)	90	25 (0,18)	< 0.002 (50)	< 0.003 (76)	+/- 0.0002 (5)	+ 0.0002 to - 0.0032 (5) (81)	
	<i>Preloaded</i> (S129)	1,160 (526)	3,150 (1428)		40 (0,28)		0		+ 0.0002 to - 0.0002 (5) (5)	

## Footnotes:

(1) Dynamic load capacity of screw based on 1 million inches of travel (25Km).

## Screws - Acme &amp; Ball

SCREW	GROUND BALL SCREWS							
	Dyn. <sup>(1)</sup> Capacity lbs (kg)	Static Capacity lbs (kg)	Screw Efficiency %	Breakaway Torque oz-in (N-m)	Position Accuracy inch/ft (microns/300 mm)	Backlash inches (microns)	Unidirectional Repeatability inches (microns)	Bidirectional Repeatability inches (microns)
0.625 dia., 0.200 lead (2) <i>Preloaded</i> (S212)	987 (447)	3,080 (1397)	90	20 (0,14)	< 0.002 (50)	0	+/- 0.0002 (5)	+ 0.0002 to - 0.0002 (5)
0.625 dia., 0.500 lead (2) <i>Preloaded</i> (S213)	1430 (649)	4,191 (1901)	90	30 (0,21)	< 0.002 (50)	0	+/- 0.0002 (5)	+ 0.0002 to - 0.0002 (5)
16 mm dia., 5 mm lead (2) <i>Preloaded</i> (S214)	987 (447)	3,080 (1397)	90	20 (0,14)	< 0.002 (50)	0	+/- 0.0002 (5)	+ 0.0002 to - 0.0002 (5)
16 mm dia., 16 mm lead (2) <i>Preloaded</i> (S215)	910 (412)	1,800 (816)	90	35 (0,24)	< 0.002 (50)	0	+/- 0.0002 (5)	+ 0.0002 to - 0.0002 (5)

SCREW	ROLLED ACME SCREWS							
	Dyn. <sup>(1)</sup> Capacity lbs (kg)	Static Capacity lbs (kg)	Screw Efficiency %	Breakaway Torque oz-in (N-m)	Position Accuracy inch/ft (microns/300 mm)	Backlash inches (microns)	Unidirectional Repeatability inches (microns)	Bidirectional Repeatability inches (microns)
0.625 inch dia. 0.100 inch lead	<i>Non-preloaded</i> (S300)	160 (73)	800 (363)	40	10 (0,07)	< 0.008 (203)	+/- 0.0002 (5)	+ 0.0002 to - 0.0082 (5)
	<i>Preloaded</i> (S301)	140 (64)	720 (327)		20 (0,14)	< 0.003 (75)		0
0.625 inch dia. 0.200 inch lead	<i>Non-preloaded</i> (S302)	160 (73)	800 (363)	40	15 (0,11)	< 0.008 (203)	+/- 0.0002 (5)	+ 0.0002 to - 0.0082 (5)
	<i>Preloaded</i> (S303)	140 (64)	720 (327)		30 (0,21)	< 0.003 (75)		0

## Footnotes:

- (1) Dynamic load capacity of screw based on 1 million inches of travel (25Km).  
(2) The 0.625 inch & 16 mm diameter Ground Ball Screw options are only available in travel lengths where the screw length is less than 47 inches (1194 mm).

Linear Bearing Load Capacities

The following equation, and graphs, can be used to help determine the linear bearing life, and load capacity, of a 610 series 6 inch carriage positioning table.

$$L = \left[ \frac{R}{F \times S} \right]^3 \times B$$

- L** = calculated travel life (millions of inches or Km)
- R** = rated dynamic load capacity of carriage (or each bearing) at 2 million inches of travel or 50 Km
- F** = user applied load
- S** = safety factor (1 to 8)
- B** = either 2 (for millions of inches) or 50 (for Km)

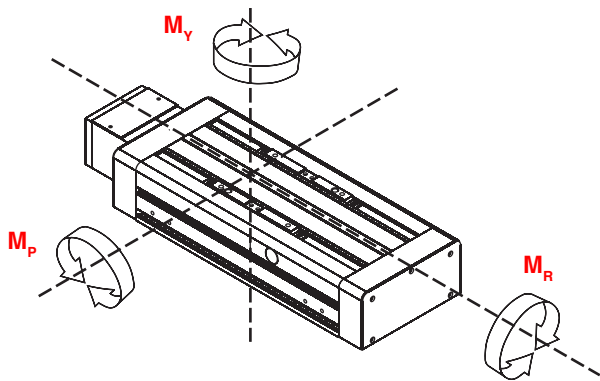

Dynamic Horizontal Load Capacity

Load Centered on Carriage

travel life		4 Bearing	
millions of inches	(Km)	lbs	(kg)
2	( 50)	7,780	(3530)
50	(1270)	2,650	(1202)
100	(2540)	2,090	(948)

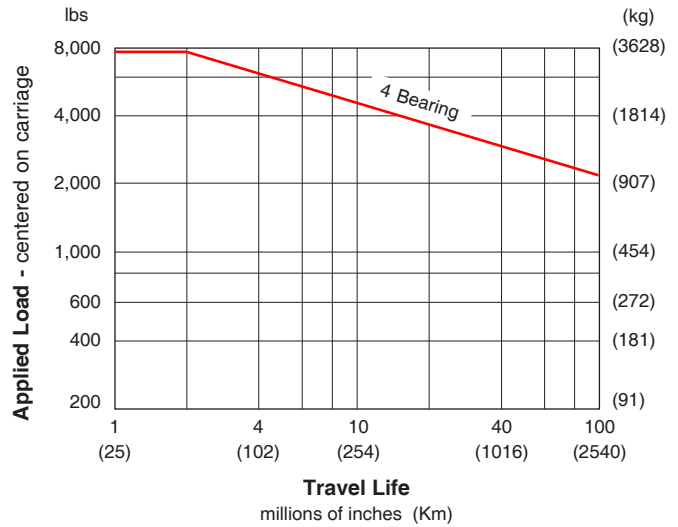

Dynamic Moment Load (Mr) Capacity

Load applied away from Carriage Center

travel life		4 Bearing	
millions of inches	(Km)	ft-lbs	(N-m)
2	( 50)	920	(1247)
50	(1270)	313	(424)
100	(2540)	247	(335)

Ratings are based on d<sub>3</sub> = 12 inches (305 mm) & d<sub>4</sub> = 0

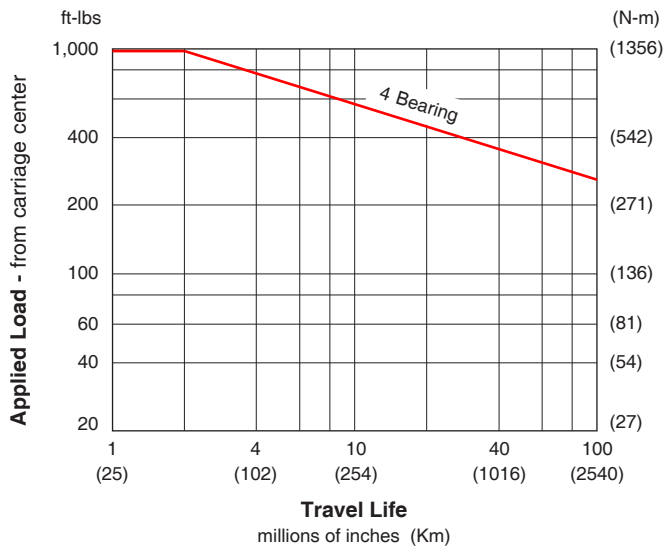

Dynamic Moment Load (Mp & My) Capacity

Load applied away from Carriage Center

travel life		4 Bearing	
millions of inches	(Km)	ft-lbs	(N-m)
2	( 50)	980	(1328)
50	(1270)	334	(453)
100	(2540)	263	(356)

Ratings are based on d<sub>3</sub> = 0 & d<sub>4</sub> = 12 inches (305 mm)

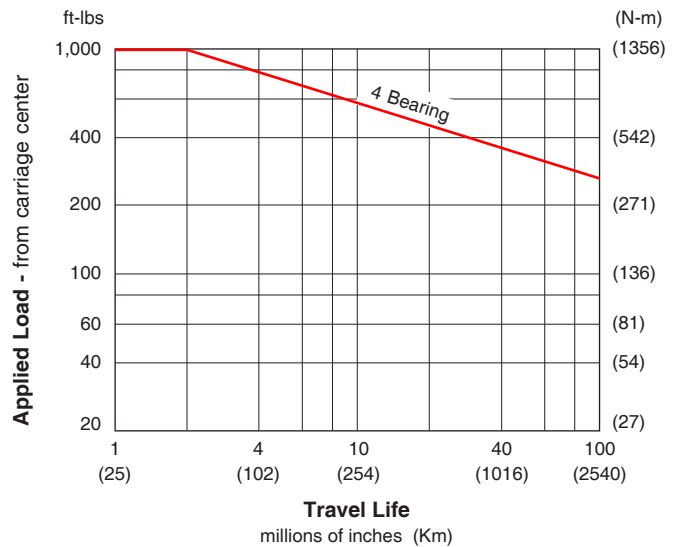

Specifications subject to change without notice

End of Travel (EOT) Switches & Home Switch

LINTECH provides several options for EOT & home switches. One style uses mechanically actuated switches, while other styles use "non-contact" versions. When ordered with a LINTECH 610 series table, each switch is mounted to the side of the table, while the actuating cams are mounted to the carriage assembly. The T-slot which runs along both sides of the 610 series, allows the switches to be located anywhere along the table. The switches are pre-wired by LINTECH for easy interfacing to the users Motion Controller.

End of Travel (EOT) Switches

End of travel (EOT) switches can be utilized by a motion controller to stop carriage motion, thereby preventing any damage to personnel, table carriage, or user mounted load if the extreme end of travel has been reached by the carriage. There are two EOT switches mounted to the side of the table, one on each end. The CCW switch is mounted at the motor mount end, while the CW switch is located at the opposite end of the table. LINTECH provides normally closed (NC) end of travel switches. This provides for a power-off fail safe system, where the position controller can detect broken wires. It is highly recommended that any positioning table used with a position controller, should have end of travel switches installed for protection of personnel, table carriage, and user mounted load.

Home Switch

The home switch can be utilized by a motion controller as a known fixed reference location on the positioning table. The switch is located between the EOT switches, near the motor mount end, and is a normally open (NO) switch.

Switch Locations

The following diagram shows the locations of the switches when ordered from LINTECH. Switches can be located on left or right hand side. Below diagram shows -LxxL (left side - when looking at non-driven end plate).

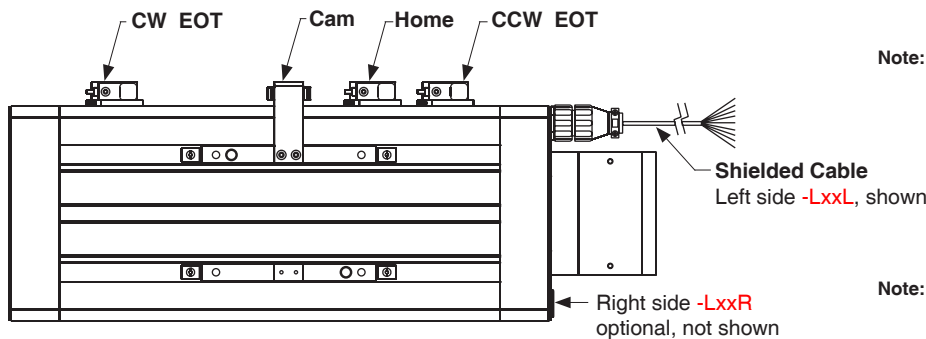

Note: For the 610 series (no waycover versions), EOT switches are normally located 0.125 inches (3 mm) inward from the maximum travel hard stops. Thus, reducing overall system travel by 0.25 inches (6 mm) from listed table travel for each model #.

Note: Switches can be located anywhere on the T-slots, which run on both sides of the unit.

Switch Type	Cost	Repeatability inches (microns)	Actuated	Power Supply Required	Activation Area inches (mm)	Comments
mechanical	least expensive	+/- 0.0002 (5)	mechanical	No	1.75 (44,45)	for most applications
reed	slightly more	+/- 0.0020 (50)	magnetic	No	0.30 (7,62)	for non-contact & low repeatable applications
hall effect	medium priced	+/- 0.0002 (5)	magnetic	Yes	0.32 (8,13)	for non-contact and wash down applications
proximity	most expensive	+/- 0.0002 (5)	non-magnetic	Yes	1.75 (44,45)	for non-contact, high speed, & wash down applications

Note: The repeatability of any switch is dependent upon several factors: carriage speed, accel rate, load weight, switch style, and the position controller. LINTECH's ratings are based upon a carriage speed of 0.5 inches/sec (12.7 mm/sec) and a no load condition.

End of Travel (EOT) Switches & Home Switch

**Mechanical Switches**

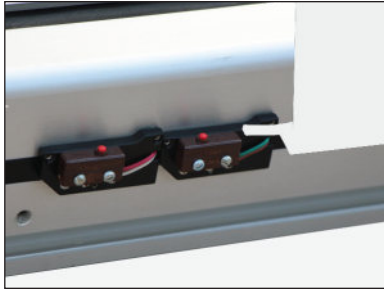

- Repeatability : +/- 0.0002 inch (5 microns)
- Electrical : 5 amps @ 125 VAC  
1 amp @ 85 VDC
- Activation Style : mechanical cam
- Activation Area : 1.75 inches (44,45 mm) of travel
- Temperature Range : - 25° C to + 85° C
- Environment : non wash down
- Added Table Width : 0.063 inch (1,6 mm) (EOT switches)  
0.063 inch (1,6 mm) (Home switch)

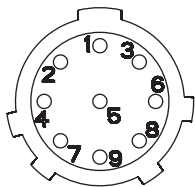
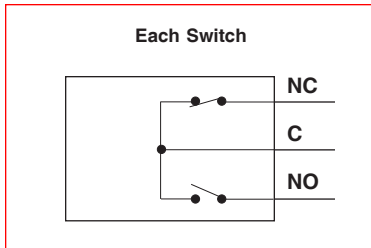

Standard *LINTECH* Wiring  
(provided with switch option)

Female connector wired to:  
10 foot (3 m) shielded cable,  
6 conductor, 24 AWG,  
unterminated leads

Pin	Wire Color	Description
2	Black	CW EOT  NC
3	Blue	CW Common  C
5	White	CCW EOT  NC
6	Green	CCW Common  C
8	Yellow	HOME  NO
9	Grey	HOME Common  C
	Silver	Shield

**Non-Contact Reed Switches**

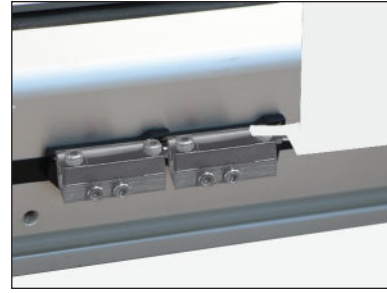

- Repeatability : +/- 0.0020 inch (50 microns)
- Electrical : 1.0 amps @ 125 VAC  
0.5 amps @ 100 VDC
- Activation Style : magnetic
- Activation Area : 0.30 inches (7,62 mm) of travel
- Temperature Range : - 10° C to + 60° C
- Environment : non wash down
- Added Table Width : 0.063 inch (1,6 mm) (EOT switches)  
0.063 inch (1,6 mm) (Home switch)

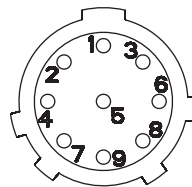
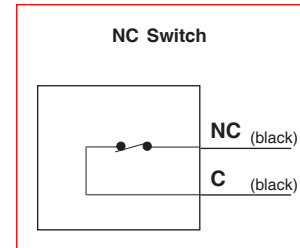
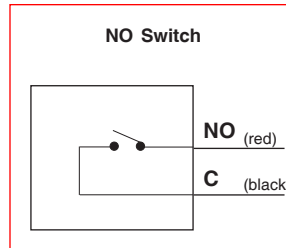

Standard *LINTECH* Wiring  
(provided with switch option)

Female connector wired to:  
10 foot (3 m) shielded cable,  
6 conductor, 24 AWG,  
unterminated leads

Pin	Wire Color	Description
2	Black	CW EOT  NC
3	Blue	CW Common  C
5	White	CCW EOT  NC
6	Green	CCW Common  C
8	Yellow	HOME  NO
9	Grey	HOME Common  C
	Silver	Shield

**Note:** Hermetically sealed mechanical switches can be ordered as an option. This may be desired for "wash down" applications. Contact *LINTECH*

Specifications subject to change without notice

End of Travel (EOT) Switches & Home Switch

**Non-Contact Hall Effect Switches**

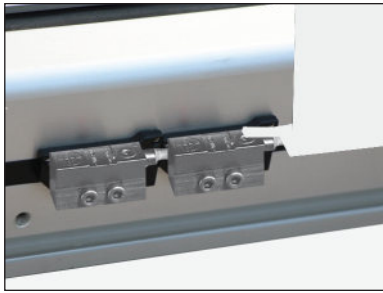

- Repeatability : +/- 0.0002 inch (5 microns)
- Electrical : 5 - 24 VDC  
15 mA - power input  
25 mA max - signal
- Actuation Style : magnetic
- Activation Area : 0.32 inches (8,13 mm) of travel
- Temperature Range : - 10° C to + 60° C
- Environment : wash down
- Added Table Width : 0.063 inch (1,6 mm) (EOT switches)  
0.063 inch (1,6 mm) (Home switch)

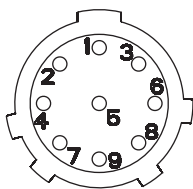
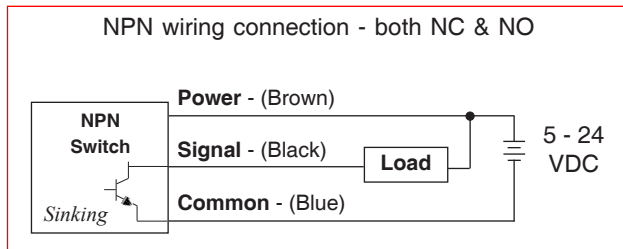

Standard *LINTECH* Wiring  
(provided with switch option)

Female connector wired to:  
10 foot (3 m) shielded cable,  
9 conductor, 24 AWG,  
unterminated leads

Pin	Wire Color	Description
1	Brown	CW Power (brown)
2	Black	CW EOT (black) switch NC
3	Blue	CW Common (blue)
4	Red	CCW Power (brown)
5	White	CCW EOT (black) switch NC
6	Green	CCW Common (blue)
7	Orange	Home Power (brown)
8	Yellow	Home (black) switch NO
9	Grey	Home Common (blue)
	Silver	Shield

**Non-Contact Proximity Switches**

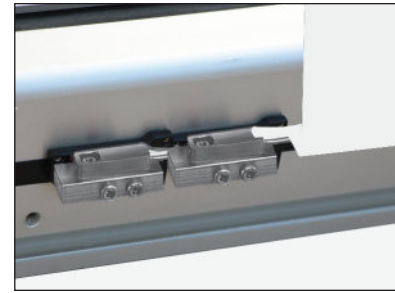

- Repeatability : +/- 0.0002 inch (5 microns)
- Electrical : 10 - 28 VDC  
15 mA - power input  
100 mA max - signal
- Actuation Style : non-magnetic cam
- Activation Area : 1.75 inches (44,45 mm) of travel
- Temperature Range : - 25° C to + 75° C
- Environment : IEC IP67 wash down
- Added Table Width : 0.20 inch (5,1 mm) (EOT switches)  
0.20 inch (5,1 mm) (Home switch)

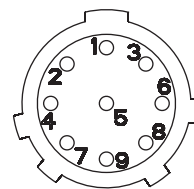
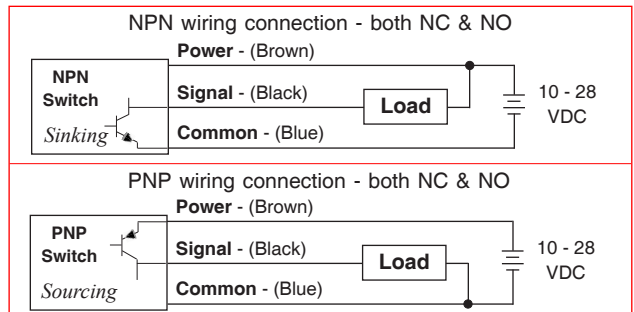

Standard *LINTECH* Wiring  
(provided with switch option)

Female connector wired to:  
10 foot (3 m) shielded cable,  
9 conductor, 24 AWG,  
unterminated leads

Pin	Wire Color	Description
1	Brown	CW Power (brown)
2	Black	CW EOT (black) switch NC
3	Blue	CW Common (blue)
4	Red	CCW Power (brown)
5	White	CCW EOT (black) switch NC
6	Green	CCW Common (blue)
7	Orange	Home Power (brown)
8	Yellow	Home (black) switch NO
9	Grey	Home Common (blue)
	Silver	Shield

Specifications subject to change without notice

## Motor Couplings

*LINTECH* provides three different types of couplings that can be used to mount a motor to a positioning table. These couplings compensate for misalignment between the motor shaft & screw (or belt) drive shaft extension. This provides for trouble-free operation as long as certain precautions are taken. The connected motor output torque should never exceed the coupling maximum torque capacity. Larger capacity couplings may be required for applications having high accelerations, large back driving loads, high torque output motors, or servo motors.

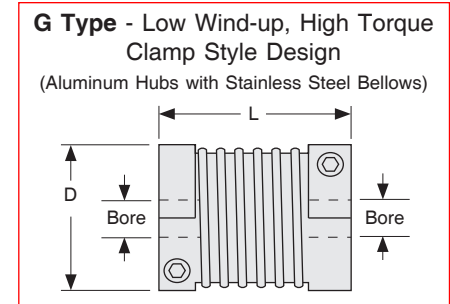
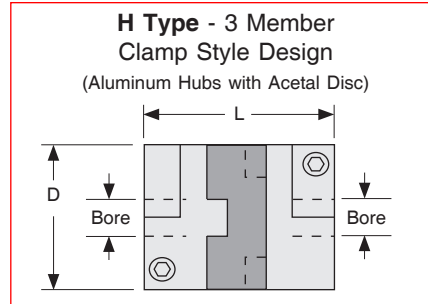
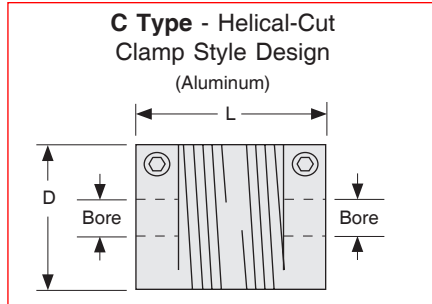

Model Number (1)	D inches (mm)	L inches (mm)	Bore Diameters				Weight ounces (grams)	Inertia oz-in <sup>2</sup> (g-cm <sup>2</sup> )	Wind-up arc-sec/oz-in (deg/N-m)	Max Torque oz-in (N-m)
			Table	Motor	Minimum (in) (mm)	Maximum (in) (mm)				
<b>C100-375-aaa</b>	1.00 (25,4)	1.50 (38,1)	<b>375</b>	<b>aaa</b>	.250 6	.375 10	1.5 (43)	.19 (35)	23.0 (0,9)	400 (2,8)
<b>C125-375-aaa</b>	1.25 (31,8)	2.00 (50,8)	<b>375</b>	<b>aaa</b>	.250 6	.500 14	3.5 (99)	.68 (124)	15.0 (0,59)	700 (4,9)
<b>H100-375-aaa</b>	1.00 (25,4)	1.28 (32,5)	<b>375</b>	<b>aaa</b>	.250 6	.375 10	1.2 (34)	.15 (27)	7.2 (0,28)	450 (2,8)
<b>H131-375-aaa</b>	1.31 (33,3)	1.89 (48,0)	<b>375</b>	<b>aaa</b>	.250 6	.625 16	2.9 (82)	.62 (114)	2.5 (0,098)	1,000 (7,1)
<b>H163-375-aaa</b>	1.63 (41,4)	2.00 (50,8)	<b>375</b>	<b>aaa</b>	.375 10	.750 20	5.4 (153)	1.79 (328)	1.2 (0,047)	2,000 (14,1)
<b>G100-375-aaa</b>	0.99 (25,2)	1.26 (32,0)	<b>375</b>	<b>aaa</b>	.250 6	.500 12	1.3 (36)	.16 (29)	1.0 (0,39)	500 (3,5)
<b>G126-375-aaa</b>	1.26 (32,1)	1.62 (41,0)	<b>375</b>	<b>aaa</b>	.250 6	.625 16	2.7 (74)	.54 (99)	0.3 (0,012)	1,100 (7,7)
<b>G158-375-aaa</b>	1.58 (40,2)	1.85 (47,0)	<b>375</b>	<b>aaa</b>	.375 10	.750 20	4.3 (120)	1.34 (245)	0.2 (0,008)	2,400 (17,0)
Possible values for <b>aaa</b>	250 = .250 inch 375 = .375 inch 500 = .500 inch 625 = .625 inch				750 = .750 inch	006 = 6 mm 008 = 8 mm 009 = 9 mm 010 = 10 mm	011 = 11 mm 012 = 12 mm 014 = 14 mm 016 = 16 mm		018 = 18 mm 019 = 19 mm 020 = 20 mm	

### Footnotes:

- (1) Some couplings are either too large or too long to fit into a particular motor mount. See page E-67 for maximum coupling diameter and length specifications for use with the optional NEMA 23 & 34 motor mounts. Visit our website to see which couplings are available and fit into other standard motor mounts. Custom motor mounts can be provided upon request.



## Motor Couplings

Coupling	Cost	Torque Capacity	Wind-up	Suggested Motor	Comments
<b>C Type</b>	least expensive	light	the most	stepper	ideal for most step motor applications
<b>H Type</b>	medium priced	medium	medium	stepper or servo	use for high accels & for starting & stopping large inertia loads
<b>G Type</b>	most expensive	high	the least	servo	use for very high torque requirements & very high servo accelerations

Specification	610 Series NEMA 23 bracket	610 Series NEMA 34 bracket
	inches (mm)	inches (mm)
<b>Shaft extension diameter at motor mount end</b>	0.375 (9,53)	0.375 (9,53)
<b>Maximum coupling diameter</b>	1.500 (38,10)	1.500 (38,10)
<b>Maximum coupling length</b>	1.750 (44,45)	2.250 (57,15)
<b>Note:</b> Custom brackets available upon request.		

## Coupling Part Numbers

<b>C025</b> C100-375-250	<b>C130</b> H100-375-250	<b>C190</b> H163-375-375	<b>C407</b> G100-375-250	<b>C470</b> G158-375-375
<b>C026</b> C100-375-375	<b>C131</b> H100-375-375	<b>C191</b> H163-375-500	<b>C408</b> G100-375-375	<b>C471</b> G158-375-500
<b>C027</b> C100-375-006	<b>C132</b> H100-375-006	<b>C192</b> H163-375-625	<b>C409</b> G100-375-500	<b>C472</b> G158-375-625
<b>C028</b> C100-375-008	<b>C133</b> H100-375-008	<b>C193</b> H163-375-750	<b>C410</b> G100-375-006	<b>C473</b> G158-375-750
<b>C030</b> C100-375-009	<b>C135</b> H100-375-009	<b>C194</b> H163-375-010	<b>C411</b> G100-375-008	<b>C474</b> G158-375-010
<b>C029</b> C100-375-010	<b>C134</b> H100-375-010	<b>C195</b> H163-375-012	<b>C414</b> G100-375-009	<b>C514</b> G158-375-011
	<b>C136</b> H100-375-011	<b>C196</b> H163-375-014	<b>C412</b> G100-375-010	<b>C475</b> G158-375-012
<b>C048</b> C125-375-250		<b>C197</b> H163-375-016	<b>C415</b> G100-375-011	<b>C476</b> G158-375-014
<b>C049</b> C125-375-375	<b>C155</b> H131-375-250	<b>C198</b> H163-375-018	<b>C413</b> G100-375-012	<b>C477</b> G158-375-016
<b>C050</b> C125-375-500	<b>C156</b> H131-375-375	<b>C199</b> H163-375-019		<b>C478</b> G158-375-018
<b>C051</b> C125-375-006	<b>C157</b> H131-375-500	<b>C200</b> H163-375-020	<b>C435</b> G126-375-250	<b>C479</b> G158-375-019
<b>C052</b> C125-375-008	<b>C158</b> H131-375-625		<b>C436</b> G126-375-375	<b>C480</b> G158-375-020
<b>C053</b> C125-375-010	<b>C159</b> H131-375-006		<b>C437</b> G126-375-500	
<b>C054</b> C125-375-012	<b>C160</b> H131-375-008		<b>C438</b> G126-375-625	
<b>C055</b> C125-375-014	<b>C183</b> H131-375-009		<b>C439</b> G126-375-006	
<b>C069</b> C125-375-016	<b>C161</b> H131-375-010		<b>C440</b> G126-375-008	
	<b>C184</b> H131-375-011		<b>C463</b> G126-375-009	
	<b>C162</b> H131-375-012		<b>C441</b> G126-375-010	
	<b>C163</b> H131-375-014		<b>C464</b> G126-375-011	
	<b>C164</b> H131-375-016		<b>C442</b> G126-375-012	
			<b>C443</b> G126-375-014	
			<b>C444</b> G126-375-016	

### NEMA 34 Motor Mount

A NEMA 34 aluminum motor adapter bracket can be mounted to the 610, series positioning tables. The bracket can be ordered in either an English, or Metric motor mount. *LINTECH* can provide adapter brackets for any step motor, or servo motor, that has other mounting requirements.

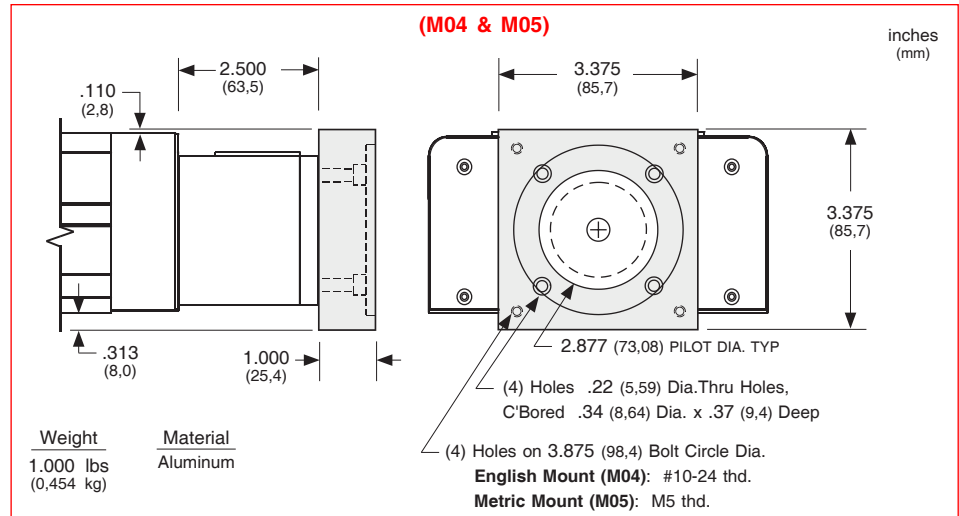

### Hand Crank

For manually operated applications, *LINTECH* provides a hand crank option for the 610 table series. The hand crank replaces the motor mount and coupling on the table.

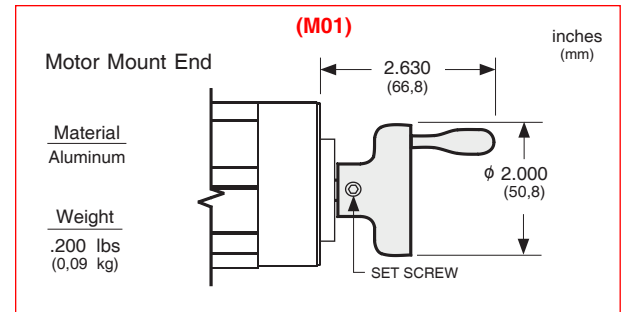

### Other Motor Mounts

*LINTECH* can provide motor adapter brackets for any step motor, or servo motor, that has mounting requirements other than what are shown in this catalog. Please review our Website for the latest information on standard motor mounts that are readily available. Listed as standard options include some: Rockwell, Mitsubishi, Praker, and Yaskawa metric motors models.

### Motor Wrap Packages for 610 Series

For space limited 610 series applications, a belt and pulley system can couple the screw shaft extension to the motor shaft. This wraps the motor parallel to the table in order to decrease the overall positioning system length. Pulley weights and diameters are given in order to assist in calculating motor torque requirements.

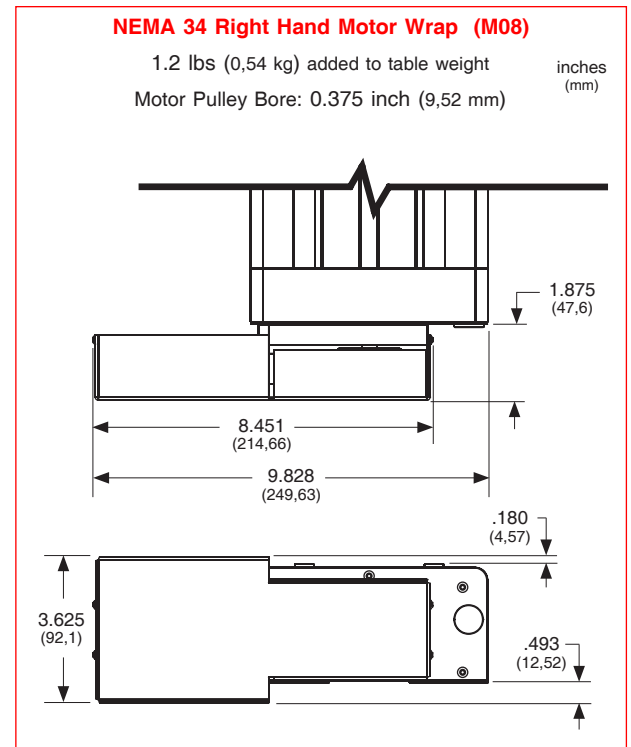
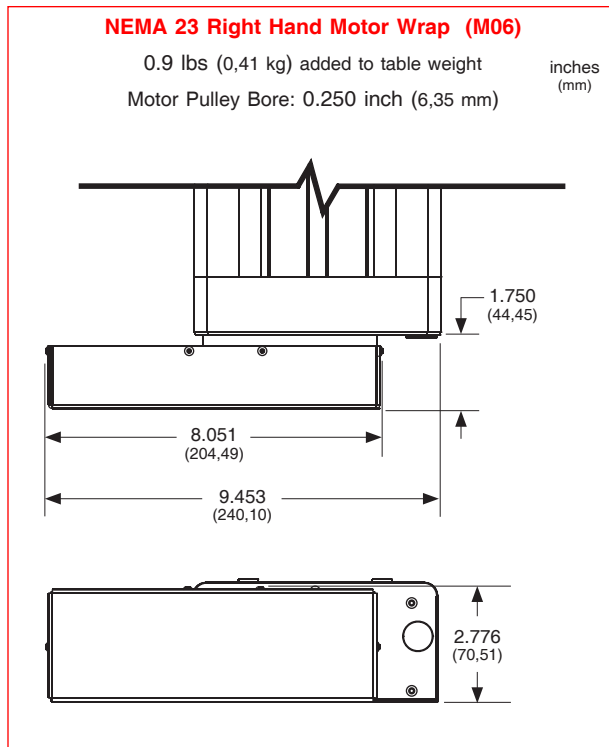

Motor Wrap Frame Size	Motor Pulley Dia. inches (mm)	Motor Pulley Wt. ounces (kg)	Screw Pulley Dia. inches (mm)	Screw Pulley Wt. ounces (kg)	Belt Weight ounces (kg)
<b>NEMA 23</b>	1.65 (41,9)	7.5 (0,21)	1.65 (41,9)	7.5 (0,21)	1.0 (0,028)
<b>NEMA 34</b>	1.65 (41,9)	8.0 (0,23)	1.65 (41,9)	8.0 (0,23)	1.2 (0,034)

**Note:** Right hand motor wraps shown. The left hand wrap packages orient the motor to the opposite side of the table. Motor pulley & belt shipped "loose". No motor mount nuts & bolts are provided. Custom motor wrap packages are available upon request. Other motor pulley bores MUST be specified for non-NEMA motors.

### Chrome Plated Linear Bearings, Rails, and Screws

For applications in high moisture, high humidity, clean room, or highly corrosive environments, chrome plating of the linear bearings, linear rails, and screw will offer superior resistance to corrosion than stainless steel components, resulting in longer table life. The process uniformly deposits dense, hard, high chromium alloy on the rails or screw, and has a Rockwell C hardness value of 67-72. This process also conforms to MIL Spec: (MIL-C-23422). The chrome plating bonds to the parent material and will not crack or peel off under the high point loading of balls on the rail, or screw. This chrome plating process differs from a normal hard chrome plate which just lays on the surface of the part plated.

## 610-SE Power-off Electric Brakes

For vertical table applications, or for those applications requiring the load to be locked securely in place, an electric brake may be mounted to the positioning table. The 610 series will have the brake mounted to the screw shaft extension located on the table end, opposite the motor mount bracket. The 620 series will have the brake mounted to the thru drive shaft option. With proper wiring from a control system, this power-off friction brake can ensure that the carriage is firmly held in place, when no electric power is applied to the brake. When power is applied to the brake, the brake is opened or "released".

For proper emergency braking of the positioning table, this electric brake needs to be interfaced to a position controller or relay network. *LINTECH* also provides 24 & 90 VDC power supplies which can be used to power the brakes.

## 610-SE Series

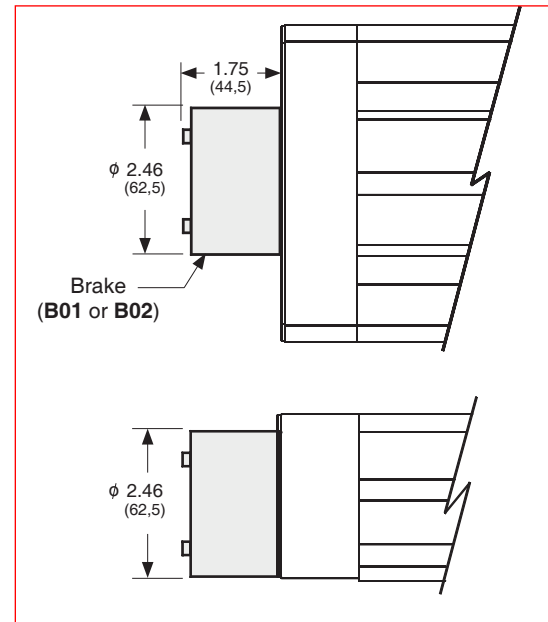
inches  
(mm)Table end opposite  
motor mount bracket

## Brakes

Model Number	Holding Force		Excitation Voltage	Current	Weight
	in-lbs (N-m)	volts			
<b>B01</b>	18 (2,0)	24 VDC	0.733	1.4 (0,62)	
<b>B02</b>	18 (2,0)	90 VDC	0.178	1.4 (0,62)	

**Note:** This power-off electric brake MUST NOT be engaged when the positioning table is in motion. Moving the table with the brake applied could damage the brake and the positioning table. Also, continuous use of this brake to stop a table (load) that is in motion could damage the brake and the positioning table. Dynamic braking of a positioning table should be done by the motor and not the brake.

## Power Supplies

Model Number	DC Output			AC Input		
	volts	amps	style	volts	amps	Hz
<b>41970</b>	5	3.0	regulated	120 / 240	0.8 / 0.4	47-63
<b>37488</b>	24	1.2	regulated	120 / 240	0.8 / 0.4	47-63
<b>37489</b>	90	0.8	unregulated	120	1.0	50/60
<b>37490</b>	90	0.8	unregulated	240	0.5	50/60

## Rotary Incremental Encoders

Incremental, optical rotary encoders can be mounted to the end of the *LINTECH* 610-SE series table. These shaft-less optical rotary encoders are mounted to the screw shaft extension opposite the motor mount end. These encoders provide positional feedback to either a motion controller, or a digital position display.

Din Pin #	Wire Color	Description
C	White	Channel A+ (or A)
D	Blue	Channel A- (or $\bar{A}$ )
E	Green	Channel B+ (or B)
L	Orange	Channel B- (or $\bar{B}$ )
G	White/Black	Channel Z+ (or Z)
H	Red/Black	Channel Z- (or $\bar{Z}$ )
A		Case ground
B	Black	Common
K	Red	+ 5 vdc (+/- 5%)

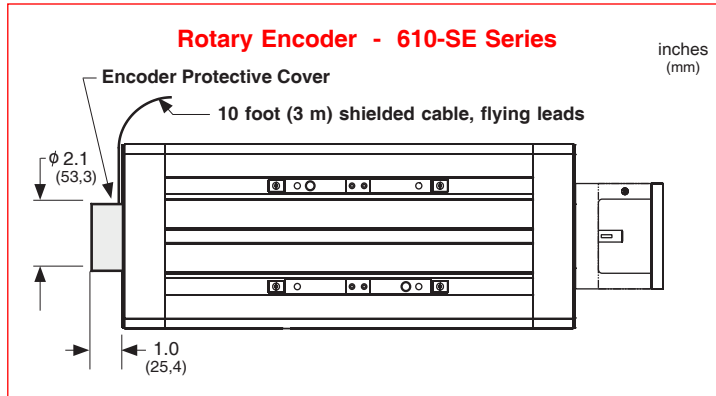

Specification	ROTARY ENCODERS		
	E01	E02	E03
Line Count	500 lines/rev	1000 lines/rev	1270 lines/rev
Pre Quadrature Resolution	0.002 revs/pulse	0.001 revs/pulse	0.00079 revs/pulse
Post Quadrature Resolution	0.0005 revs/pulse	0,00025 revs/pulse	0.00019 revs/pulse
Accuracy			
Maximum Speed	50 revs/sec		
Maximum Accel	40 revs/sec <sup>2</sup>		
Excitation Power	+ 5 VDC @ 125 ma		
Operating Temperature	32° F to 140° F (0° C to 60° C)		
Humidity	20% to 80% non condensing		
Shock	10 G's for 11 msec duration		
Weight	0.7 lbs (0,283 kg)		
Cable Length	10 ft (3 m), unterminated 26 gauge leads		
Zero Reference Output	Once per revolution		
Outputs	TTL square wave; 2 channel (A+/B+); Differential (A-/B-); Line Driver		

**Multi-Axis Configurations**

*LINTECH* can provide adapter plates & vertical brackets, to facilitate the construction of X-Y, X-Z, X-Y-Z, Cartesian, and other multi-axis configurations. There are hundreds of possible configurations available. See below for some common systems. *LINTECH* has experience dealing with multiple axis configurations. Sometimes different standard table series can be mounted to form a custom system. Other times, a custom assembly can be created. Contact *LINTECH* for more information.

