

**18 4 6 004 - CP1 - 1 - D1 - M02 - C155 - L04 - E00 - B00**

**Table Series** \_\_\_\_\_

**Number of Bearings** \_\_\_\_\_

- 2** - 2 bearings per carriage
- 4** - 4 bearings per carriage

**Carriage Length** \_\_\_\_\_

- 6** - 6 inches

**Travel Length** (see pages E-40, E-42, E-44 & E-46) \_\_\_\_\_

- 003** - 3 to 108 inches

**Cover Plate** \_\_\_\_\_

- CP0** - no cover plates
- CP1** - top cover plate only
- CP2** - top & side cover plates
- WC1** - waycovers

**Carriage Inserts** (see pages E-41, E-43, E-45, & E-47) \_\_\_\_\_

- 1** - English mount
- 2** - Metric mount

**Drive Shaft** (see pages E-41, E-43, E-45 & E-47) \_\_\_\_\_

- D1** - Right Hand single shaft
- D2** - Left Hand single shaft
- D3** - Right Hand thru shaft
- D4** - Left Hand thru shaft

**Motor Mount** (see pages E-41, E-43, E-45, E-47 & E-68) \_\_\_\_\_

- M00** - none
- M20 to M98** - see Website
- M99** - other
- M02** - NEMA 23 mount (E)
- M03** - NEMA 23 mount (M)
- M04** - NEMA 34 mount (E)
- M05** - NEMA 34 mount (M)

**Coupling Options** (see pages E-66 & E-67) \_\_\_\_\_

- C000** - none
- C999** - none
- C130 to C136** - H100
- C155 to C184** - H131
- C190 to C200** - H163
- C407 to C415** - G100
- C435 to C464** - G126
- C470 to C514** - G158

**Limit & Home Switches** (see pages E-63 to E-65) \_\_\_\_\_

- |                          |                     |            |            |            |            |
|--------------------------|---------------------|------------|------------|------------|------------|
| <b>L00</b> - no switches |                     | Reed       | Hall       | Prox (NPN) | Prox (PNP) |
| <b>L99</b> - other       | EOT & home switches | <b>L04</b> | <b>L07</b> | <b>L10</b> | <b>L13</b> |
|                          | EOT switches only   | <b>L05</b> | <b>L08</b> | <b>L11</b> | <b>L14</b> |
|                          | home switch only    | <b>L06</b> | <b>L09</b> | <b>L12</b> | <b>L15</b> |

**Encoder Options** (see page E-71) \_\_\_\_\_

- E00** - none
- E01** - rotary (500 lines/rev)
- E02** - rotary (1000 lines/rev)
- E03** - rotary (1270 lines/rev)
- E99** - other

*note: When selecting any rotary encoder option, the Drive Shaft D3 or D4 above is required.*

**Power-off Brakes** (see page E-70) \_\_\_\_\_

- B00** - none
- B01** - 24 VDC
- B02** - 90 VDC
- B99** - other

*note: When selecting any brake option, the Drive Shaft D3 or D4 above is required.*

(E) - English Interface  
(M) - Metric Interface

### Specifications

Load Capacities		Two (2) Bearing Carriage		Four (4) Bearing Carriage	
<b>Dynamic Horizontal</b>	2 million inches (50 km) of travel	3,890 lbs	( 1765 kg)	7,780 lbs	( 3530 kg)
<b>Dynamic Horizontal</b>	100 million inches (2540 km) of travel	1,045 lbs	( 474 kg)	2,090 lbs	( 948 kg)
<b>Static Horizontal</b>		5,820 lbs	( 2640 kg)	11,640 lbs	( 5280 kg)
<b>Dynamic Roll Moment</b>	2 million inches (50 km) of travel	510 ft-lbs	( 690 N-m)	1,025 ft-lbs	( 1390 N-m)
<b>Dynamic Roll Moment</b>	100 million inches (2540 km) of travel	137 ft-lbs	( 185 N-m)	275 ft-lbs	( 370 N-m)
<b>Static Roll Moment</b>		915 ft-lbs	( 1240 N-m)	1,830 ft-lbs	( 2480 N-m)
<b>Dyn. Pitch &amp; Yaw Moment</b>	2 million inches (50 km) of travel	71 ft-lbs	( 96 N-m)	930 ft-lbs	( 1260 N-m)
<b>Dyn. Pitch &amp; Yaw Moment</b>	100 million inches (2540 km) of travel	19 ft-lbs	( 26 N-m)	250 ft-lbs	( 339 N-m)
<b>Static Pitch &amp; Yaw Moment</b>		126 ft-lbs	( 170 N-m)	1,670 ft-lbs	( 2260 N-m)
<b>Each Bearing Dyn. Capacity</b>	2 million inches (50 km) of travel	1,945 lbs	( 882 kg)	1,945 lbs	( 882 kg)
<b>Each Bearing Dyn. Capacity</b>	100 million inches (2540 km) of travel	525 lbs	( 238 kg)	525 lbs	( 238 kg)
<b>Each Bearing Static Load Capacity</b>		2,910 lbs	( 1320 kg)	2,910 lbs	( 1320 kg)
<b>Maximum Belt Tensile Force</b>		350 lbs	( 159 kg)	350 lbs	( 159 kg)
<b>Maximum Carriage Thrust Force</b>		230 lbs	( 104 kg)	230 lbs	( 104 kg)
<b>Maximum Speed</b>		118 in/sec	( 3 m/sec)	118 in/sec	( 3 m/sec)
<b>Maximum Acceleration</b>		386 in/sec <sup>2</sup>	( 9,8 m/sec <sup>2</sup> )	772 in/sec <sup>2</sup>	( 19,6 m/sec <sup>2</sup> )
<b>d<sub>1</sub></b>	Center to center distance (spread) between the two rails	3.660 in	( 92,96 mm)	3.660 in	( 92,96 mm)
<b>d<sub>2</sub></b>	Center to center distance (spacing) of the bearings on a single rail		-	3.290 in	( 83,57 mm)
<b>d<sub>r</sub></b>	Center distance of the bearing to top of carriage plate surface	1.320 in	( 33,53 mm)	1.320 in	( 33,53 mm)

Other	For Two (2) & Four (4) Bearing Carriages
<b>Table Material</b>	Base, Carriage, End Plates, & Cover Plate - 6061 anodized aluminum
<b>Linear Rail Material</b>	Case Hardened Steel
<b>Belt Properties</b>	Black, 32 mm wide, Polyurethane, Steel reinforced belt
<b>Drive Pulley Weight</b>	0.39 lbs ( 0,18 kg)
<b>Drive Pulley Diameter</b>	1.128 in ( 28,65 mm)
<b>Drive Lead</b>	3.543 in ( 90,00 mm)
<b>Belt Stretch - x Load (lbs or N)</b>	0.00011 in/ft per lbs ( 0,00212 mm/m per N)
<b>Unidirectional Repeatability</b>	+/- 0.001 in (+/- 0,0254 mm)
<b>Bidirectional Repeatability</b>	+/- 0.004 in (+/- 0,1016 mm)
<b>Position Accuracy (Belt) <sup>(1)</sup></b>	< 0.010 in/ft (< 0,254 mm/300mm)
<b>Orthogonality (multi-axis systems)</b>	< 30 arc-seconds
<b>Friction Coefficient</b>	< 0.01
<b>Breakaway Torque</b>	< 75 oz-in (0,530 N-m)
<b>Motor Mount</b>	NEMA 23 & 34 Mounts, Metric Mounts, and Gearheads
<b>Coupling</b>	Two (2) different styles available
<b>Waycover Material</b>	Hypilon Polyester Bellows mounted to carriage & end plates

#### Footnotes:

(1) Position accuracy varies based on belt stretch. The given rating is based upon a carriage speed of 5 inches/sec (127 mm/sec) and a no load condition.

### Dimensions & Specifications

- Without Cover Plates -

Model Number	Travel Length inches (mm)	Table Dimensions inches (mm)		Mounting Dimensions inches (mm)		Belt Weight ounces (kg)	Table <sup>(1)</sup> Weight lbs (kg)
		A	B	C	M		
18x6006-CP0	6 (150)	12.125 (308,0)	18.250 (463,6)	3	8	3.8 (0,11)	17.4 (7,9)
18x6012-CP0	12 (300)	18.125 (460,4)	24.250 (616,0)	5	12	5.3 (0,15)	19.6 (8,9)
18x6018-CP0	18 (455)	24.125 (612,8)	30.250 (768,4)	7	16	6.8 (0,19)	21.8 (9,9)
18x6024-CP0	24 (605)	30.125 (765,2)	36.250 (920,8)	9	20	8.3 (0,23)	24.0 (10,9)
18x6030-CP0	30 (760)	36.125 (917,6)	42.250 (1073,2)	11	24	9.8 (0,28)	26.2 (11,9)
18x6036-CP0	36 (910)	42.125 (1070,0)	48.250 (1225,6)	13	28	11.3 (0,32)	28.4 (12,9)
18x6042-CP0	42 (1060)	48.125 (1222,4)	54.250 (1378,0)	15	32	12.8 (0,36)	30.6 (13,9)
18x6048-CP0	48 (1215)	54.125 (1374,8)	60.250 (1530,4)	17	36	14.3 (0,41)	32.8 (14,9)
18x6054-CP0	54 (1370)	60.125 (1527,1)	66.250 (1682,7)	19	40	15.8 (0,45)	35.0 (15,9)
18x6060-CP0	60 (1520)	66.125 (1679,6)	72.250 (1835,2)	21	44	17.3 (0,49)	37.2 (16,9)
18x6072-CP0	72 (1825)	78.125 (1984,4)	84.250 (2140,0)	25	52	20.3 (0,58)	41.6 (18,9)
18x6084-CP0	84 (2130)	90.125 (2289,2)	96.250 (2444,8)	29	60	23.3 (0,66)	46.0 (20,9)
18x6096-CP0	96 (2435)	102.125 (2594,0)	108.250 (2749,6)	33	68	26.3 (0,75)	50.4 (22,9)
18x6108-CP0	108 (2740)	114.125 (2898,8)	120.250 (3054,4)	37	76	29.3 (0,83)	54.8 (24,9)

{

 x = 2; Carriage has 2 bearings; Carriage weight = 2.5 lbs. (1,13 kg)  
 x = 4; Carriage has 4 bearings; Carriage weight = 3.3 lbs. (1,50 kg)

#### Footnotes:

(1) Weight shown is with a 2 bearing carriage [2.5 lbs (1,13 kg)], a NEMA 23 motor mount [0.39 lbs (0,18 kg)], and a H100 style [0.08 lbs (0,04 kg)] coupling. When using a 4 bearing carriage add 0.8 lbs (0,36 kg) to each value.

Dimensions

- Without Cover Plates -

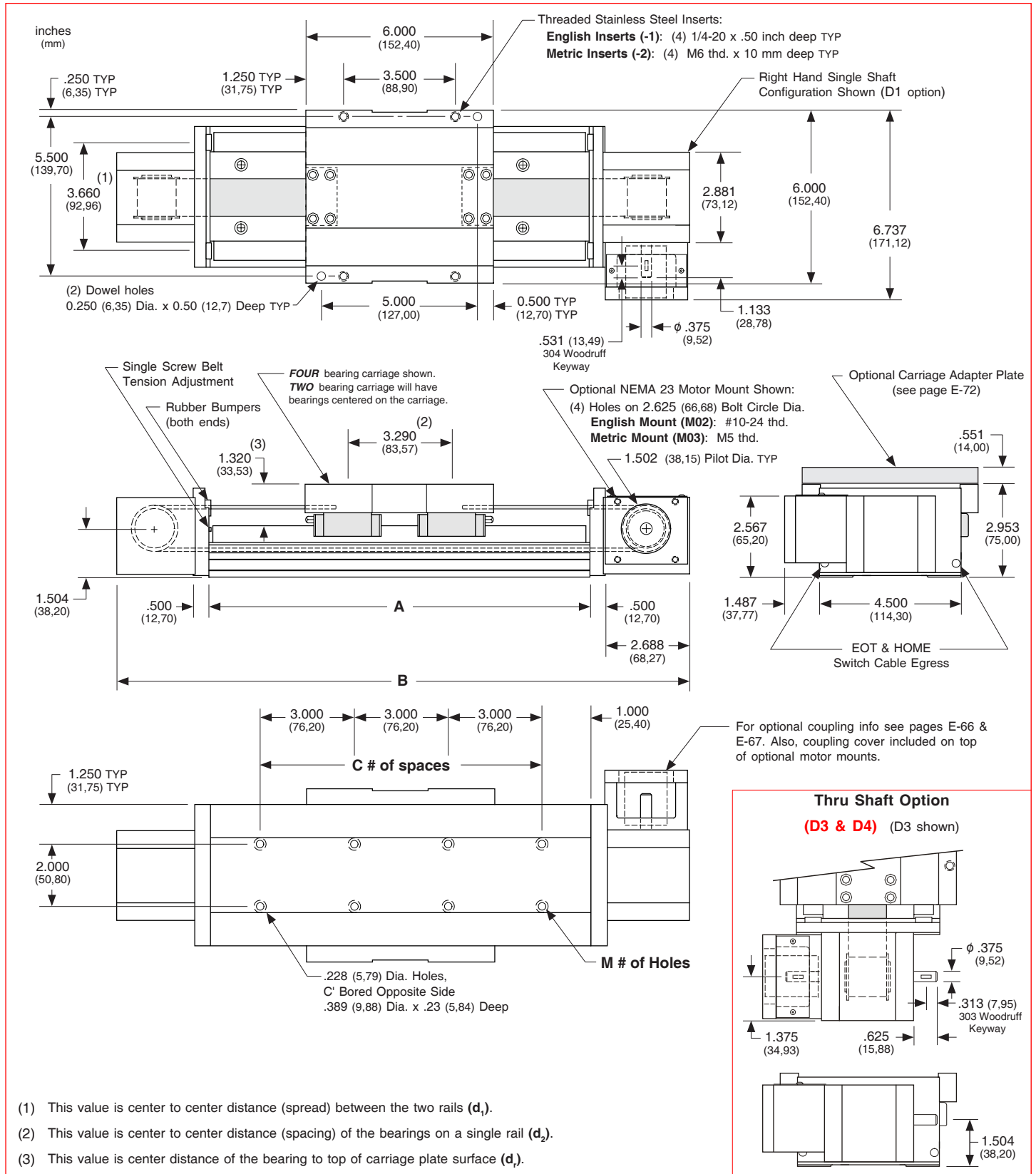

### Dimensions & Specifications

- With Top Cover Plate Only -

Model Number	Travel <sup>(1)</sup> inches (mm)	Table Dimensions inches (mm)		Mounting Dimensions inches (mm)		Belt Weight ounces (kg)	Table <sup>(2)</sup> Weight lbs (kg)
		A	B	C	M		
18x6006-CP1	6 (150)	12.125 (308,0)	18.250 (463,6)	3	8	3.8 (0,11)	18.2 (8,3)
18x6012-CP1	12 (300)	18.125 (460,4)	24.250 (616,0)	5	12	5.3 (0,15)	20.8 (9,4)
18x6018-CP1	18 (455)	24.125 (612,8)	30.250 (768,4)	7	16	6.8 (0,19)	23.4 (10,6)
18x6024-CP1	24 (605)	30.125 (765,2)	36.250 (920,8)	9	20	8.3 (0,23)	26.0 (11,8)
18x6030-CP1	30 (760)	36.125 (917,6)	42.250 (1073,2)	11	24	9.8 (0,28)	28.6 (13,0)
18x6036-CP1	36 (910)	42.125 (1070,0)	48.250 (1225,6)	13	28	11.3 (0,32)	31.2 (14,2)
18x6042-CP1	42 (1060)	48.125 (1222,4)	54.250 (1378,0)	15	32	12.8 (0,36)	33.8 (15,3)
18x6048-CP1	48 (1215)	54.125 (1374,8)	60.250 (1530,4)	17	36	14.3 (0,41)	36.4 (16,5)
18x6054-CP1	54 (1370)	60.125 (1527,1)	66.250 (1682,7)	19	40	15.8 (0,45)	39.0 (17,7)
18x6060-CP1	60 (1520)	66.125 (1679,6)	72.250 (1835,2)	21	44	17.3 (0,49)	41.6 (18,9)

- x = 2; Carriage has 2 bearings; Carriage weight = 2.5 lbs. (1,13 kg)
- x = 4; Carriage has 4 bearings; Carriage weight = 3.3 lbs. (1,50 kg)

#### Footnotes:

- (1) For travels greater than 60 inches (1520 mm) a top cover plate (-CP1) cannot be used due to the sag of the cover plate.
- (2) Weight shown is with a 2 bearing carriage [2.5 lbs (1,13 kg)], a NEMA 23 motor mount [0.39 lbs (0,18 kg)], and a H100 style [0.08 lbs (0,04 kg)] coupling. When using a 4 bearing carriage add 0.8 lbs (0,36 kg) to each value.

Dimensions

- With Top Cover Plate Only -

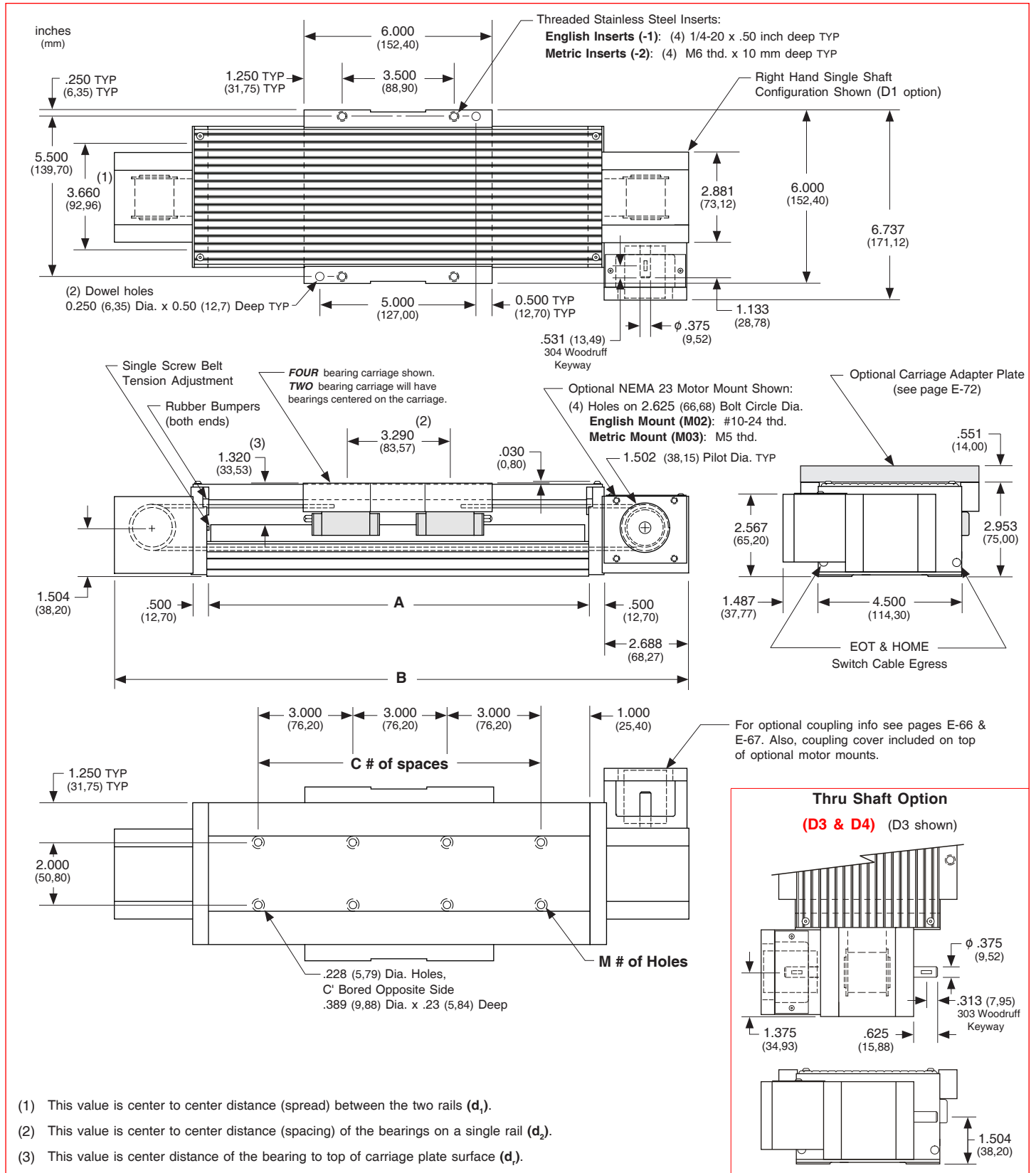

### Dimensions & Specifications

- With Top & Side Cover Plates -

Model Number	Travel Length <sup>(1)</sup> inches (mm)	Table Dimensions inches (mm)		Mounting Dimensions inches (mm)		Belt Weight ounces (kg)	Table Weight <sup>(2)</sup> lbs (kg)
		A	B	C	M		
18x6006-CP2	6 (150)	12.125 (308,0)	18.250 (463,6)	3	8	3.8 (0,11)	19.8 (9,0)
18x6012-CP2	12 (300)	18.125 (460,4)	24.250 (616,0)	5	12	5.3 (0,15)	22.7 (10,3)
18x6018-CP2	18 (455)	24.125 (612,8)	30.250 (768,4)	7	16	6.8 (0,19)	25.7 (11,7)
18x6024-CP2	24 (605)	30.125 (765,2)	36.250 (920,8)	9	20	8.3 (0,23)	28.7 (13,0)
18x6030-CP2	30 (760)	36.125 (917,6)	42.250 (1073,2)	11	24	9.8 (0,28)	31.6 (14,3)
18x6036-CP2	36 (910)	42.125 (1070,0)	48.250 (1225,6)	13	28	11.3 (0,32)	34.6 (15,7)
18x6042-CP2	42 (1060)	48.125 (1222,4)	54.250 (1378,0)	15	32	12.8 (0,36)	37.6 (17,1)
18x6048-CP2	48 (1215)	54.125 (1374,8)	60.250 (1530,4)	17	36	14.3 (0,41)	40.5 (18,4)
18x6054-CP2	54 (1370)	60.125 (1527,1)	66.250 (1682,7)	19	40	15.8 (0,45)	43.5 (19,7)
18x6060-CP2	60 (1520)	66.125 (1679,6)	72.250 (1835,2)	21	44	17.3 (0,49)	46.4 (21,0)
18x6072-CP2 <sup>(1)</sup>	72 (1825)	78.125 (1984,4)	84.250 (2140,0)	25	52	20.3 (0,58)	47.2 (21,4)
18x6084-CP2 <sup>(1)</sup>	84 (2130)	90.125 (2289,2)	96.250 (2444,8)	29	60	23.3 (0,66)	52.4 (23,8)
18x6096-CP2 <sup>(1)</sup>	96 (2435)	102.125 (2594,0)	108.250 (2749,6)	33	68	26.3 (0,75)	57.6 (26,1)
18x6108-CP2 <sup>(1)</sup>	108 (2740)	114.125 (2898,8)	120.250 (3054,4)	37	76	29.3 (0,83)	62.8 (28,5)

- ┌ x = 2; Carriage has 2 bearings; Carriage weight = 2.5 lbs. (1,13 kg)
- └ x = 4; Carriage has 4 bearings; Carriage weight = 3.3 lbs. (1,50 kg)

#### Footnotes:

- (1) For travels greater than 60 inches (1520 mm) the top cover plate cannot be used due to the sag of the cover plate. Just the two side cover plates are installed.
- (2) Weight shown is with a 2 bearing carriage [2.5 lbs (1,13 kg)], a NEMA 23 motor mount [0.39 lbs (0,18 kg)], and a H100 style [0.08 lbs (0,04 kg)] coupling. When using a 4 bearing carriage add 0.8 lbs (0,36 kg) to each value.

### Dimensions

### - With Top & Side Cover Plates -

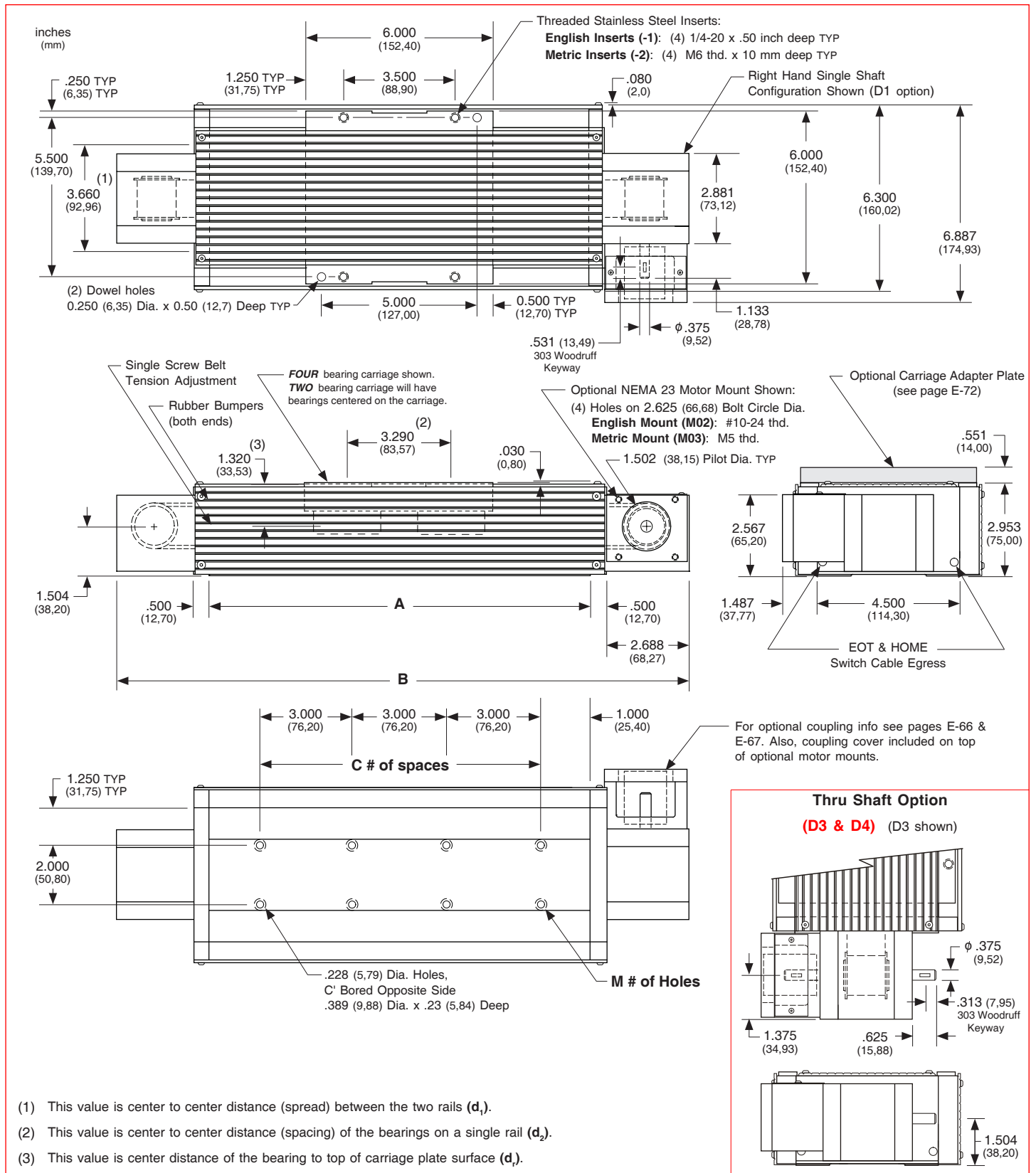



### Dimensions & Specifications

- With Waycovers -

Model Number	Travel Length inches (mm)	Table Dimensions inches (mm)		Mounting Dimensions inches (mm)		Belt Weight ounces (kg)	Table <sup>(1)</sup> Weight lbs (kg)
		A	B	C	M		
18x6003-WC1	3.7 (94)	12.125 (308,0)	18.250 (463,6)	3	8	3.8 (0,11)	18.0 (8,2)
18x6008-WC1	8.0 (203)	18.125 (460,4)	24.250 (616,0)	5	12	5.3 (0,15)	20.4 (9,3)
18x6012-WC1	12.8 (325)	24.125 (612,8)	30.250 (768,4)	7	16	6.8 (0,19)	22.8 (10,3)
18x6017-WC1	17.5 (444)	30.125 (765,2)	36.250 (920,8)	9	20	8.3 (0,23)	25.3 (11,5)
18x6022-WC1	22.0 (555)	36.125 (917,6)	42.250 (1073,2)	11	24	9.8 (0,28)	27.5 (12,7)
18x6028-WC1	28.0 (710)	42.125 (1070,0)	48.250 (1225,6)	13	28	11.3 (0,32)	29.9 (13,6)
18x6032-WC1	32.5 (825)	48.125 (1222,4)	54.250 (1378,0)	15	32	12.8 (0,36)	32.3 (14,7)
18x6037-WC1	37.0 (935)	54.125 (1374,8)	60.250 (1530,4)	17	36	14.3 (0,41)	34.7 (15,7)
18x6041-WC1	41.5 (1050)	60.125 (1527,1)	66.250 (1682,7)	19	40	15.8 (0,45)	37.2 (16,9)
18x6047-WC1	47.5 (1205)	66.125 (1679,6)	72.250 (1835,2)	21	44	17.3 (0,49)	39.8 (18,1)
18x6056-WC1	56.7 (1440)	78.125 (1984,4)	84.250 (2140,0)	25	52	20.3 (0,58)	45.0 (20,4)
18x6065-WC1	65.5 (1660)	90.125 (2289,2)	96.250 (2444,8)	29	60	23.3 (0,66)	50.2 (22,8)
18x6074-WC1	74.5 (1890)	102.125 (2594,0)	108.250 (2749,6)	33	68	26.3 (0,75)	55.4 (25,1)
18x6084-WC1	84.0 (2130)	114.125 (2898,8)	120.250 (3054,4)	37	76	29.3 (0,83)	60.6 (27,5)

- ┌ x = 2; Carriage has 2 bearings; Carriage weight = 2.5 lbs. (1,13 kg)
- └ x = 4; Carriage has 4 bearings; Carriage weight = 3.3 lbs. (1,50 kg)

#### Footnotes:

(1) Weight shown is with a 2 bearing carriage [2.5 lbs (1,13 kg)], a NEMA 23 motor mount [0.39 lbs (0,18 kg)], and a H100 style [0.08 lbs (0,04 kg)] coupling. When using a 4 bearing carriage add 0.8 lbs (0,36 kg) to each value.

Dimensions

- With Waycovers -

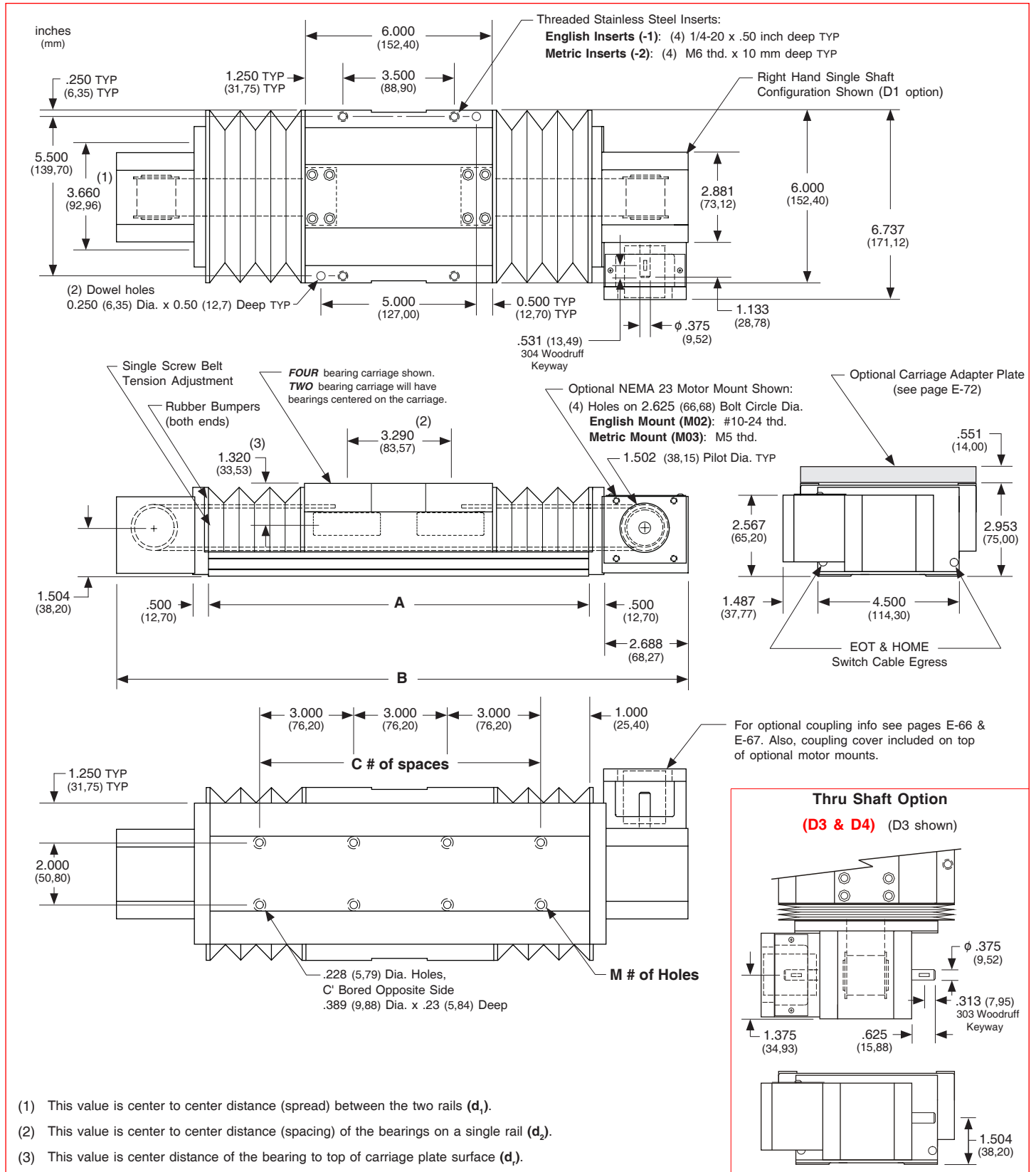

**Note:** Any 160, 170, or 180 series table can be mounted on top of a second 160, 170 or 180 series table, in order to create X-Y multiple axis configurations. See page E-72 for optional carriage adapter plate information or contact *LINTECH* for details.

**18** **4** **12** **004** - **CP1** - **1** - **D1** - **M02** - **C155** - **L04** - **E00** - **B00**

**Table Series**

**Number of Bearings**

- 4** - 4 bearings per carriage
- 6** - 6 bearings per carriage

**Carriage Length**

- 12** - 6 inches

**Travel Length** (see pages E-50, E-52, E-54 & E-56)

- 003** - 3 to 108 inches

**Cover Plate**

- CP0** - no cover plates
- CP1** - top cover plate only
- CP2** - top & side cover plates
- WC1** - waycovers

**Carriage Inserts** (see pages E-51, E-53, E-55, & E-57)

- 1** - English mount
- 2** - Metric mount

**Drive Shaft** (see pages E-51, E-53, E-55 & E-57)

- D1** - Right Hand single shaft
- D2** - Left Hand single shaft
- D3** - Right Hand thru shaft
- D4** - Left Hand thru shaft

**Motor Mount** (see pages E-51, E-53, E-55, E-57 & E-68)

- M00** - none
- M20 to M98** - see Website
- M99** - other
- M02** - NEMA 23 mount (E)
- M03** - NEMA 23 mount (M)
- M04** - NEMA 34 mount (E)
- M05** - NEMA 34 mount (M)

**Coupling Options** (see pages E-66 & E-67)

- C000** - none
- C999** - none
- C130 to C136** - H100
- C155 to C184** - H131
- C190 to C200** - H163
- C407 to C415** - G100
- C435 to C464** - G126
- C470 to C514** - G158

**Limit & Home Switches** (see pages E-63 to E-65)

- |                          |                     |            |            |            |            |
|--------------------------|---------------------|------------|------------|------------|------------|
| <b>L00</b> - no switches |                     | Reed       | Hall       | Prox (NPN) | Prox (PNP) |
| <b>L99</b> - other       | EOT & home switches | <b>L04</b> | <b>L07</b> | <b>L10</b> | <b>L13</b> |
|                          | EOT switches only   | <b>L05</b> | <b>L08</b> | <b>L11</b> | <b>L14</b> |
|                          | home switch only    | <b>L06</b> | <b>L09</b> | <b>L12</b> | <b>L15</b> |

**Encoder Options** (see page E-71)

- E00** - none
- E01** - rotary (500 lines/rev)
- E02** - rotary (1000 lines/rev)
- E03** - rotary (1270 lines/rev)
- E99** - other

*note: When selecting any rotary encoder option, the Drive Shaft D3 or D4 above is required.*

**Power-off Brakes** (see page E-70)

- B00** - none
- B01** - 24 VDC
- B02** - 90 VDC
- B99** - other

*note: When selecting any brake option, the Drive Shaft D3 or D4 above is required.*

(E) - English Interface  
(M) - Metric Interface

### Specifications

Load Capacities		Four (4) Bearing Carriage		Six (6) Bearing Carriage	
<b>Dynamic Horizontal</b>	2 million inches (50 km) of travel	7,780 lbs	( 3530 kgf)	11,670 lbs	( 5290 kgf)
<b>Dynamic Horizontal</b>	100 million inches (2540 km) of travel	2,090 lbs	( 948 kgf)	3,135 lbs	( 1420 kgf)
<b>Static Horizontal</b>		11,640 lbs	( 5280 kgf)	17,460 lbs	( 7920 kgf)
<b>Dynamic Roll Moment</b>	2 million inches (50 km) of travel	1,025 ft-lbs	( 1390 N-m)	1,540 ft-lbs	( 2085 N-m)
<b>Dynamic Roll Moment</b>	100 million inches (2540 km) of travel	275 ft-lbs	( 370 N-m)	410 ft-lbs	( 555 N-m)
<b>Static Roll Moment</b>		1,830 ft-lbs	( 2480 N-m)	2,750 ft-lbs	( 3725 N-m)
<b>Dyn. Pitch &amp; Yaw Moment</b>	2 million inches (50 km) of travel	2,160 ft-lbs	( 2925 N-m)	2,235 ft-lbs	( 3030 N-m)
<b>Dyn. Pitch &amp; Yaw Moment</b>	100 million inches (2540 km) of travel	580 ft-lbs	( 785 N-m)	600 ft-lbs	( 810 N-m)
<b>Static Pitch &amp; Yaw Moment</b>		3,860 ft-lbs	( 5230 N-m)	3,980 ft-lbs	( 5395 N-m)
<b>Each Bearing Dyn. Capacity</b>	2 million inches (50 km) of travel	1,945 lbs	( 882 kgf)	1,945 lbs	( 882 kgf)
<b>Each Bearing Dyn. Capacity</b>	100 million inches (2540 km) of travel	525 lbs	( 238 kgf)	525 lbs	( 238 kgf)
<b>Each Bearing Static Load Capacity</b>		2,910 lbs	( 1320 kgf)	2,910 lbs	( 1320 kgf)
<b>Maximum Belt Tensile Force</b>		350 lbs	( 159 kg)	350 lbs	( 159 kg)
<b>Maximum Carriage Thrust Force</b>		230 lbs	( 104 kg)	230 lbs	( 104 kg)
<b>Maximum Speed</b>		118 in/sec	( 3 m/sec)	118 in/sec	( 3 m/sec)
<b>Maximum Acceleration</b>		772 in/sec <sup>2</sup>	(19,6 m/sec <sup>2</sup> )	772 in/sec <sup>2</sup>	(19,6 m/sec <sup>2</sup> )
<b>d<sub>1</sub></b>	Center to center distance (spread) between the two rails	3.660 in	( 92,96 mm)	3.660 in	( 92,96 mm)
<b>d<sub>2</sub></b>	Center to center distance (spacing) of the bearings on a single rail	9.290 in	(235,97 mm)	4.645 in	(117,98 mm)
<b>d<sub>r</sub></b>	Center distance of the bearing to top of carriage plate surface	1.320 in	( 33,53 mm)	1.320 in	( 33,53 mm)

Other	For Four (4) & Six (6) Bearing Carriages
<b>Table Material</b>	Base, Carriage, End Plates, & Cover Plate - 6061 anodized aluminum
<b>Linear Rail Material</b>	Case Hardened Steel
<b>Belt Properties</b>	Black, 32 mm wide, Polyurethane, Steel reinforced belt
<b>Drive Pulley Weight</b>	0.39 lbs ( 0,18 kg)
<b>Drive Pulley Diameter</b>	1.128 in ( 28,65 mm)
<b>Drive Lead</b>	3.543 in ( 90,00 mm)
<b>Belt Stretch - x Load (lbs or N)</b>	0.00011 in/ft per lbs ( 0,00212 mm/m per N)
<b>Unidirectional Repeatability</b>	+/- 0.001 in (+/- 0,0254 mm)
<b>Bidirectional Repeatability</b>	+/- 0.004 in (+/- 0,1016 mm)
<b>Position Accuracy (Belt) <sup>(1)</sup></b>	< 0.010 in/ft (< 0,254 mm/300mm)
<b>Orthogonality (multi-axis systems)</b>	< 30 arc-seconds
<b>Friction Coefficient</b>	< 0.01
<b>Breakaway Torque</b>	< 75 oz-in (0,530 N-m)
<b>Motor Mount</b>	NEMA 23 & 34 Mounts, Metric Mounts, and Gearheads
<b>Coupling</b>	Two (2) different styles available
<b>Waycover Material</b>	Hypilon Polyester Bellows mounted to carriage & end plates

#### Footnotes:

(1) Position accuracy varies based on belt stretch. The given rating is based upon a carriage speed of 5 inches/sec (127 mm/sec) and a no load condition.

### Dimensions & Specifications

- Without Cover Plates -

Model Number	Travel Length inches (mm)	Table Dimensions inches (mm)		Mounting Dimensions inches (mm)		Belt Weight ounces (kg)	Table <sup>(1)</sup> Weight lbs (kg)
		A	B	C	M		
<b>18x12006-CP0</b>	6 (150)	18.125 (460,4)	24.250 (616,0)	5	12	5.3 (0,15)	22.1 (10,0)
<b>18x12012-CP0</b>	12 (300)	24.125 (612,8)	30.250 (768,4)	7	16	6.8 (0,19)	24.3 (11,0)
<b>18x12018-CP0</b>	18 (455)	30.125 (765,2)	36.250 (920,8)	9	20	8.3 (0,23)	26.5 (12,0)
<b>18x12024-CP0</b>	24 (605)	36.125 (917,6)	42.250 (1073,2)	11	24	9.8 (0,28)	28.7 (13,0)
<b>18x12030-CP0</b>	30 (760)	42.125 (1070,0)	48.250 (1225,6)	13	28	11.3 (0,32)	30.9 (14,0)
<b>18x12036-CP0</b>	36 (910)	48.125 (1222,4)	54.250 (1378,0)	15	32	12.8 (0,36)	33.1 (15,0)
<b>18x12042-CP0</b>	42 (1060)	54.125 (1374,8)	60.250 (1530,4)	17	36	14.3 (0,41)	35.3 (16,0)
<b>18x12048-CP0</b>	48 (1215)	60.125 (308,0)	66.250 (463,6)	19	40	3.8 (0,11)	37.5 (17,0)
<b>18x12054-CP0</b>	54 (1370)	66.125 (1679,6)	72.250 (1835,2)	21	44	15.8 (0,45)	39.7 (18,0)
<b>18x12066-CP0</b>	66 (1675)	78.125 (1984,4)	84.250 (2140,0)	25	52	20.3 (0,58)	44.1 (20,0)
<b>18x12078-CP0</b>	78 (1980)	90.125 (2289,2)	96.250 (2444,8)	29	60	23.3 (0,66)	48.5 (22,0)
<b>18x12090-CP0</b>	90 (2285)	102.125 (2594,0)	108.250 (2749,6)	33	68	26.3 (0,75)	52.9 (24,0)
<b>18x12102-CP0</b>	102 (2590)	114.125 (2898,8)	120.250 (3054,4)	37	76	29.3 (0,83)	57.3 (26,0)

- ┌ x = 4; Carriage has 4 bearings; Carriage weight = 5.0 lbs. (2,27 kg)
- └ x = 6; Carriage has 6 bearings; Carriage weight = 5.8 lbs. (2,63 kg)

#### Footnotes:

(1) Weight shown is with a 4 bearing carriage [5.0 lbs (2,26 kg)], a NEMA 23 motor mount [0.39 lbs (0,18 kg)], and a H100 style [0.08 lbs (0,04 kg)] coupling. When using a 6 bearing carriage add 0.8 lbs (0,36 kg) to each value.

Dimensions

- Without Cover Plates -

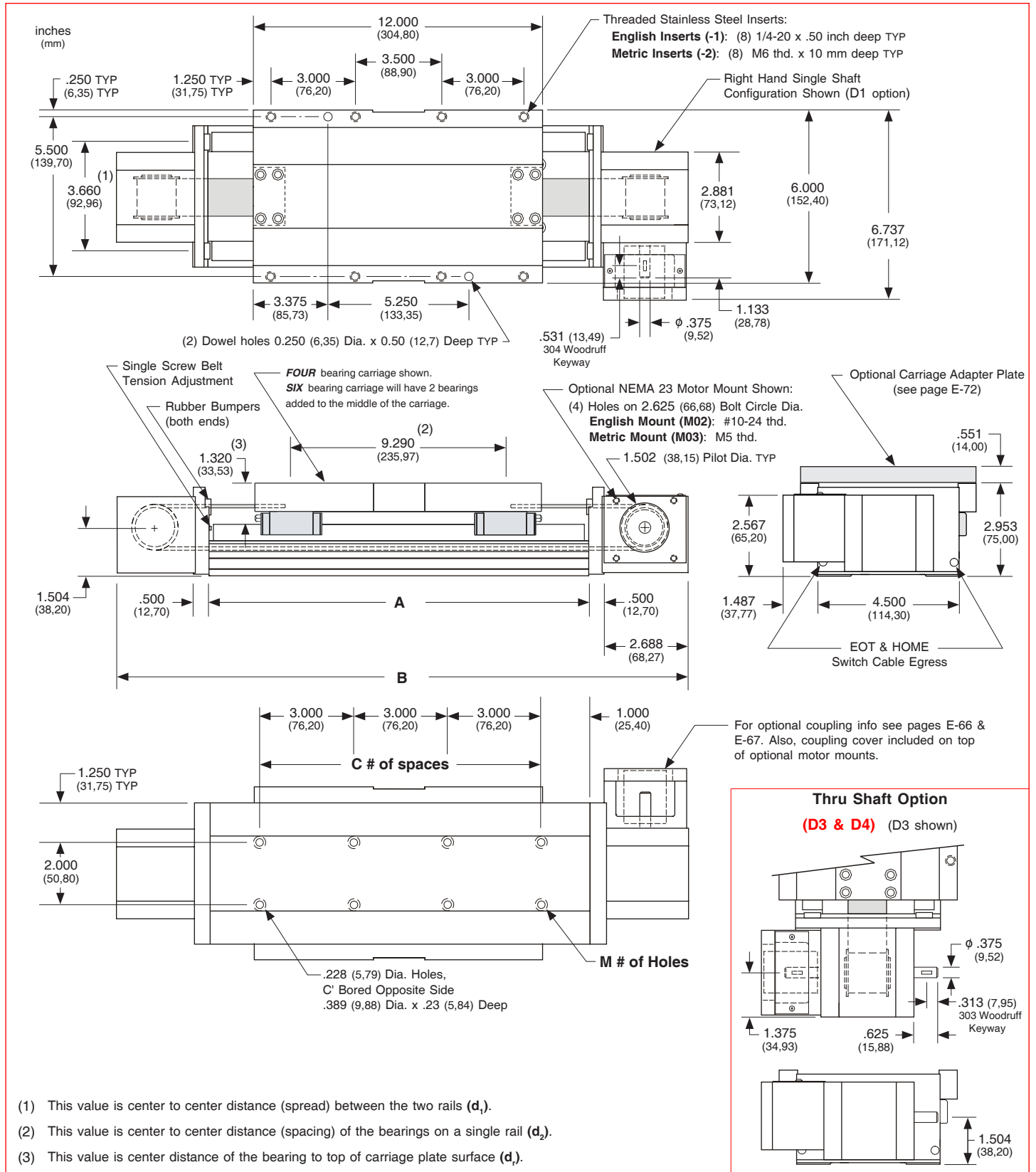

### Dimensions & Specifications

- With Top Cover Plate Only -

Model Number	Travel <sup>(1)</sup> inches (mm)	Table Dimensions inches (mm)		Mounting Dimensions inches (mm)		Belt Weight ounces (kg)	Table <sup>(2)</sup> Weight lbs (kg)
		A	B	C	M		
18x12006-CP1	6 (150)	18.125 (460,4)	24.250 (616,0)	5	12	5.3 (0,15)	23.3 (10,6)
18x12012-CP1	12 (300)	24.125 (612,8)	30.250 (768,4)	7	16	6.8 (0,19)	25.9 (11,7)
18x12018-CP1	18 (455)	30.125 (765,2)	36.250 (920,8)	9	20	8.3 (0,23)	28.5 (12,9)
18x12024-CP1	24 (605)	36.125 (917,6)	42.250 (1073,2)	11	24	9.8 (0,28)	31.1 (14,1)
18x12030-CP1	30 (760)	42.125 (1070,0)	48.250 (1225,6)	13	28	11.3 (0,32)	33.7 (15,3)
18x12036-CP1	36 (910)	48.125 (1222,4)	54.250 (1378,0)	15	32	12.8 (0,36)	36.3 (16,5)
18x12042-CP1	42 (1060)	54.125 (1374,8)	60.250 (1530,4)	17	36	14.3 (0,41)	38.9 (17,6)
18x12048-CP1	48 (1215)	60.125 (308,0)	66.250 (463,6)	19	40	3.8 (0,11)	41.5 (18,8)
18x12054-CP1	54 (1370)	66.125 (1679,6)	72.250 (1835,2)	21	44	17.3 (0,49)	44.1 (20,0)

- x = 4; Carriage has 4 bearings; Carriage weight = 5.0 lbs. (2,27 kg)
- x = 6; Carriage has 6 bearings; Carriage weight = 5.8 lbs. (2,63 kg)

#### Footnotes:

- (1) For travels greater than 54 inches (1520 mm) a top cover plate (-CP1) cannot be used due to the sag of the cover plate.
- (2) Weight shown is with a 4 bearing carriage [5.0 lbs (2,26 kg)], a NEMA 23 motor mount [0.39 lbs (0,18 kg)], and a H100 style [0.08 lbs (0,04 kg)] coupling. When using a 6 bearing carriage add 0.8 lbs (0,36 kg) to each value.





### Dimensions & Specifications

- With Top & Side Cover Plates -

Model Number	Travel Length <sup>(1)</sup> inches (mm)	Table Dimensions inches (mm)		Mounting Dimensions inches (mm)		Belt Weight ounces (kg)	Table Weight <sup>(2)</sup> lbs (kg)
		A	B	C	M		
18x12006-CP2	6 (150)	12.125 (308,0)	18.250 (463,6)	3	8	3.8 (0,11)	25.2 (11,4)
18x12012-CP2	12 (300)	18.125 (460,4)	24.250 (616,0)	5	12	5.3 (0,15)	28.2 (12,8)
18x12018-CP2	18 (455)	24.125 (612,8)	30.250 (768,4)	7	16	6.8 (0,19)	31.2 (14,2)
18x12024-CP2	24 (605)	30.125 (765,2)	36.250 (920,8)	9	20	8.3 (0,23)	34.1 (15,5)
18x12030-CP2	30 (760)	36.125 (917,6)	42.250 (1073,2)	11	24	9.8 (0,28)	37.1 (16,8)
18x12036-CP2	36 (910)	42.125 (1070,0)	48.250 (1225,6)	13	28	11.3 (0,32)	40.1 (18,2)
18x12042-CP2	42 (1060)	48.125 (1222,4)	54.250 (1378,0)	15	32	12.8 (0,36)	43.0 (19,5)
18x12048-CP2	48 (1215)	54.125 (1374,8)	60.250 (1530,4)	17	36	14.3 (0,41)	46.0 (20,9)
18x12054-CP2	54 (1370)	66.125 (1679,6)	72.250 (1835,2)	21	44	17.3 (0,49)	48.9 (22,2)
18x12066-CP2 <sup>(1)</sup>	66 (1675)	78.125 (1984,4)	84.250 (2140,0)	25	52	20.3 (0,58)	49.7 (22,5)
18x12078-CP2 <sup>(1)</sup>	78 (1980)	90.125 (2289,2)	96.250 (2444,8)	29	60	23.3 (0,66)	54.9 (24,9)
18x12090-CP2 <sup>(1)</sup>	90 (2285)	102.125 (2594,0)	108.250 (2749,6)	33	68	26.3 (0,75)	60.1 (27,3)
18x12102-CP2 <sup>(1)</sup>	102 (2590)	114.125 (2898,8)	120.250 (3054,4)	37	76	29.3 (0,83)	65.3 (29,6)

- x = 4; Carriage has 4 bearings; Carriage weight = 5.0 lbs. (2,27 kg)
- x = 6; Carriage has 6 bearings; Carriage weight = 5.8 lbs. (2,63 kg)

#### Footnotes:

- (1) For travels greater than 60 inches (1520 mm) the top cover plate cannot be used due to the sag of the cover plate. Just the two side cover plates are installed.
- (2) Weight shown is with a 4 bearing carriage [5.0 lbs (2,26 kg)], a NEMA 23 motor mount [0.39 lbs (0,18 kg)], and a H100 style [0.08 lbs (0,04 kg)] coupling. When using a 6 bearing carriage add 0.8 lbs (0,36 kg) to each value.

Dimensions

- With Top & Side Cover Plates -

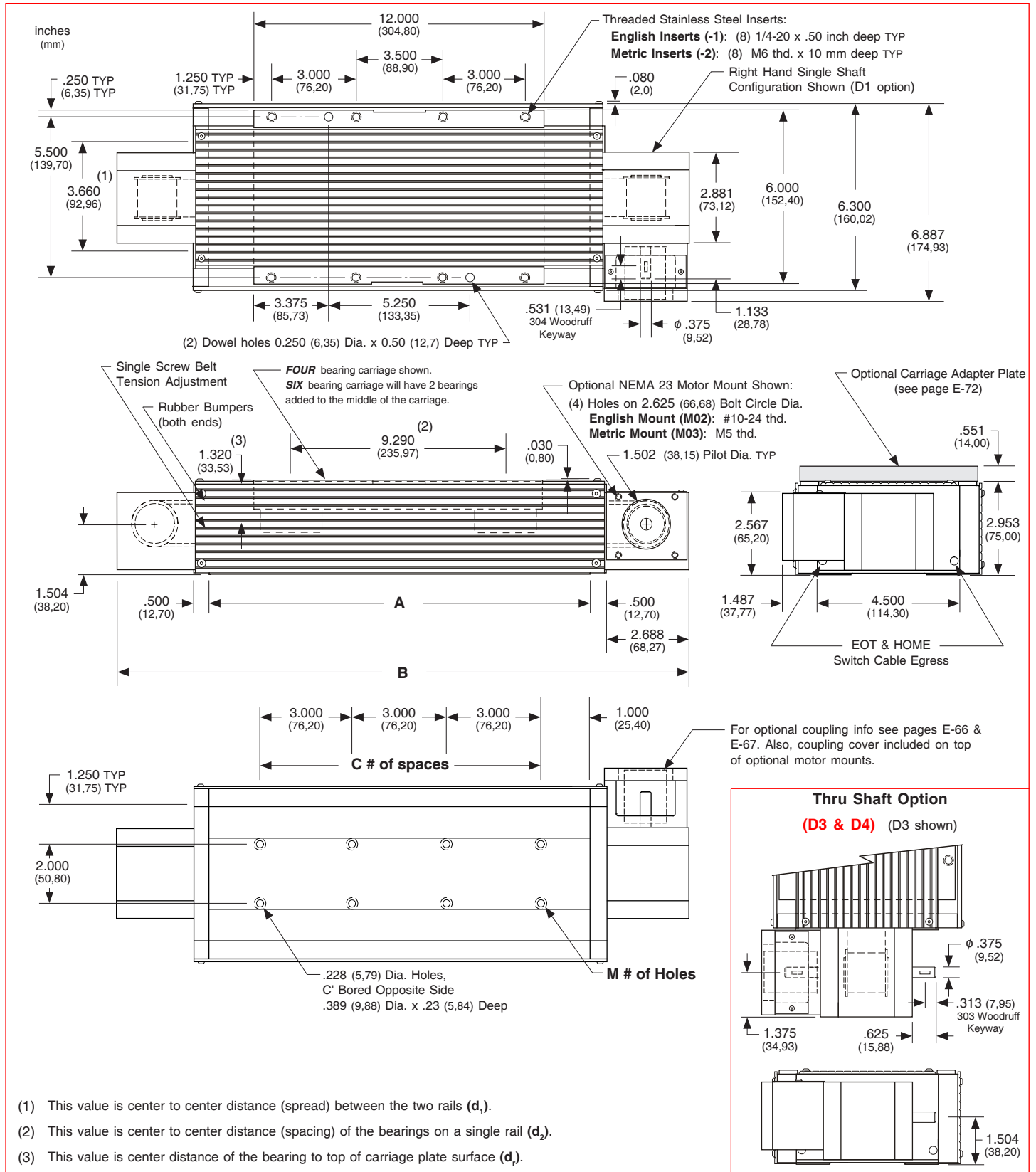

**Note:** Any 160, 170, or 180 series table can be mounted on top of a second 160, 170 or 180 series table, in order to create X-Y multiple axis configurations. See page E-72 for optional carriage adapter plate information or contact *LINTECH* for details.

### Dimensions & Specifications

- With Waycovers -

Model Number	Travel Length inches (mm)	Table Dimensions inches (mm)		Mounting Dimensions inches (mm)		Belt Weight ounces (kg)	Table <sup>(1)</sup> Weight lbs (kg)
		A	B	C	M		
<b>18x12003-WC1</b>	3.7 (90)	12.125 (308,0)	18.250 (463,6)	3	8	3.8 (0,11)	22.9 (10,4)
<b>18x12008-WC1</b>	8.0 (203)	18.125 (460,4)	24.250 (616,0)	5	12	5.3 (0,15)	25.3 (11,5)
<b>18x12012-WC1</b>	12.8 (325)	24.125 (612,8)	30.250 (768,4)	7	16	6.8 (0,19)	27.8 (12,6)
<b>18x12017-WC1</b>	17.5 (444)	30.125 (765,2)	36.250 (920,8)	9	20	8.3 (0,23)	30.0 (13,6)
<b>18x12022-WC1</b>	22.0 (555)	36.125 (917,6)	42.250 (1073,2)	11	24	9.8 (0,28)	32.4 (14,7)
<b>18x12028-WC1</b>	28.0 (710)	42.125 (1070,0)	48.250 (1225,6)	13	28	11.3 (0,32)	34.8 (15,8)
<b>18x12032-WC1</b>	32.5 (825)	48.125 (1222,4)	54.250 (1378,0)	15	32	12.8 (0,36)	37.2 (16,9)
<b>18x12037-WC1</b>	37.0 (935)	54.125 (1374,8)	60.250 (1530,4)	17	36	14.3 (0,41)	39.7 (18,0)
<b>18x12041-WC1</b>	41.5 (1050)	66.125 (1679,6)	72.250 (1835,2)	21	44	17.3 (0,49)	42.3 (19,2)
<b>18x12053-WC1</b>	53.5 (1355)	78.125 (1984,4)	84.250 (2140,0)	25	52	20.3 (0,58)	47.5 (21,5)

{

 x = 4; Carriage has 4 bearings; Carriage weight = 5.0 lbs. (2,27 kg)  
 x = 6; Carriage has 6 bearings; Carriage weight = 5.8 lbs. (2,63 kg)

#### Footnotes:

(1) Weight shown is with a 4 bearing carriage [5.0 lbs (2,26 kg)], a NEMA 23 motor mount [0.39 lbs (0,18 kg)], and a H100 style [0.08 lbs (0,04 kg)] coupling. When using a 6 bearing carriage add 0.8 lbs (0,36 kg) to each value.

Dimensions

- With Waycovers -

