

17 2 6 06 - CP1 - 1 - S005 - M02 - C155 - L01 - E00 - B00

Table Series

Number of Bearings

2 - 2 bearings **4** - 4 bearings

Carriage Length

6 - 6 inches

Travel Length (see pages E-10, E-12, E-14 & E-16)

06 - 3 to 60 inches

Cover Plate

CP0 - no cover plates **CP1** - top cover plate only **CP2** - top & side cover plates **WC1** - waycovers

Carriage Inserts (see pages E-11, E-13, E-15 & E-17)

1 - English mount **2** - Metric mount

Screw Options (see pages E-30 to E-35)

<i>Rolled ball screws</i>	<i>Rolled ball screws</i>	<i>Precision ball screws</i>
S005 - .625 x .200 NPL	S017 - .750 x .500 NPL	S114 - .625 x .200 NPL
S006 - .625 x .200 PL	S018 - .750 x .500 PL	S115 - .625 x .200 PL
S007 - .625 x .200 NPL(T)	S019 - .750 x .500 NPL(T)	S116 - 16 x 5 NPL
S008 - .625 x .200 PL(T)	S020 - .750 x .500 PL(T)	S117 - 16 x 5 PL
S009 - .625 x 1.000 NPL		S118 - 16 x 10 NPL
S010 - .625 x 1.000 PL	<i>Ground ball screws</i>	S119 - 16 x 10 PL
S011 - .625 x 1.000 NPL(T)	S212 - .625 x .200 PL	S120 - 16 x 16 NPL
S012 - .625 x 1.000 PL(T)	S213 - .625 x .500 PL	S121 - 16 x 16 PL
S013 - .750 x .200 NPL	S214 - 16 x 5 PL	S122 - .750 x .200 NPL
S014 - .750 x .200 PL	S215 - 16 x 16 PL	S123 - .750 x .200 PL
S015 - .750 x .200 NPL(T)	<i>Rolled acme screws</i>	S124 - 20 x 5 NPL
S016 - .750 x .200 PL(T)	S300 - .625 x .100 NPL	S125 - 20 x 5 PL
	S301 - .625 x .100 PL	S128 - 20 x 20 NPL
S999 - other	S302 - .625 x .200 NPL	S129 - 20 x 20 PL
	S303 - .625 x .200 PL	

Motor Mount (see pages E-11, E-13, E-15, E-17, E-68 & E-69)

M00 - none	M02 - NEMA 23 mount (E)	M06 - NEMA 23 (RH) wrap
M01 - hand crank	M03 - NEMA 23 mount (M)	M07 - NEMA 23 (LH) wrap
M20 to M98 - see Website	M04 - NEMA 34 mount (E)	M08 - NEMA 34 (RH) wrap
M99 - other	M05 - NEMA 34 mount (M)	M09 - NEMA 34 (LH) wrap

Coupling Options (see pages E-66 to E-67)

C000 - none	C025 to C030 - C100	C130 to C136 - H100	C407 to C415 - G100
C999 - other	C048 to C069 - C125	C155 to C184 - H131	C435 to C464 - G126
		C190 to C200 - H163	C470 to C514 - G158

Limit & Home Switches (see pages E-63 to E-65)

L00 - no switches	Mechanical	Reed	Hall	Prox (NPN)	Prox (PNP)
L99 - other	EOT & home switches	L01	L04	L07	L10
	EOT switches only	L02	L05	L08	L11
	home switch only	L03	L06	L09	L12
				L12	L15

Encoder Options (see page E-71)

E00 - none	E02 - rotary (1000 lines/rev)	E10 - linear (2500 lines/inch)	E99 - other
E01 - rotary (500 lines/rev)	E03 - rotary (1270 lines/rev)	E11 - linear (125 lines/mm)	

Power-off Brakes (see page E-70)

B00 - none	B01 - 24 VDC	B02 - 90 VDC	B99 - other	(E) - English Interface	(NPL) - Non Preloaded
				(LH) - Left Hand	(PL) - Preloaded
				(M) - Metric Interface	(RH) - Right Hand
					(T) - Turcite Nut

Specifications subject to change without notice

Specifications

Load Capacities		Two (2) Bearing Carriage		Four (4) Bearing Carriage	
Dynamic Horizontal	2 million inches (50 km) of travel	3,890 lbs	(1765 kgf)	7,780 lbs	(3530 kgf)
Dynamic Horizontal	100 million inches (2540 km) of travel	1,045 lbs	(474 kgf)	2,090 lbs	(948 kgf)
Static Horizontal		5,820 lbs	(2640 kgf)	11,640 lbs	(5280 kgf)
Dynamic Roll Moment	2 million inches (50 km) of travel	510 ft-lbs	(690 N-m)	1,025 ft-lbs	(1390 N-m)
Dynamic Roll Moment	100 million inches (2540 km) of travel	137 ft-lbs	(185 N-m)	275 ft-lbs	(370 N-m)
Static Roll Moment		915 ft-lbs	(1240 N-m)	1,830 ft-lbs	(2480 N-m)
Dyn. Pitch & Yaw Moment	2 million inches (50 km) of travel	71 ft-lbs	(96 N-m)	930 ft-lbs	(1260 N-m)
Dyn. Pitch & Yaw Moment	100 million inches (2540 km) of travel	19 ft-lbs	(26 N-m)	250 ft-lbs	(339 N-m)
Static Pitch & Yaw Moment		126 ft-lbs	(170 N-m)	1,670 ft-lbs	(2260 N-m)
Each Bearing Dyn. Capacity	2 million inches (50 km) of travel	1,945 lbs	(882 kgf)	1,945 lbs	(882 kgf)
Each Bearing Dyn. Capacity	100 million inches (2540 km) of travel	525 lbs	(238 kgf)	525 lbs	(238 kgf)
Each Bearing Static Load Capacity		2,910 lbs	(1320 kgf)	2,910 lbs	(1320 kgf)
Thrust Force Capacity	10 million screw revolutions	895 lbs	(406 kgf)	895 lbs	(406 kgf)
Thrust Force Capacity	500 million screw revolutions	240 lbs	(109 kgf)	240 lbs	(109 kgf)
Maximum Acceleration		386 in/sec ²	(9,8 m/sec ²)	772 in/sec ²	(19,6 m/sec ²)
d₁	Center to center distance (spread) between the two rails	3.660 in	(92,96 mm)	3.660 in	(92,96 mm)
d₂	Center to center distance (spacing) of the bearings on a single rail		-	3.290 in	(83,57 mm)
d_r	Center distance of the bearing to top of carriage plate surface	1.320 in	(33,53 mm)	1.320 in	(33,53 mm)

Other	For Two (2) & Four (4) Bearing Carriages
Table Material	Base, Carriage, End Plates & Cover Plate Option - 6061 anodized aluminum
Linear Rail Material	Case Hardened Steel
Screw Material (see pages E-30 to E-35)	Acme Screw - Stainless Steel
Screw Material (see pages E-30 to E-35)	Rolled Ball, Precision Ball, & Ground Ball - Case Hardened Steel
Unidirectional Repeatability	+/- 0.0002 in (5 microns)
Bidirectional Repeatability	+/- 0.0002 in (5 microns) to +/- 0.0082 in (208 microns) - depends on selected screw
Straightness	< 0.00016 in/in (< 4,06 microns/25mm)
Flatness	< 0.00016 in/in (< 4,06 microns/25mm)
Orthogonality (multi-axis systems)	< 30 arc-seconds
Friction Coefficient	< 0.01
Motor Mount	NEMA 23 & 34 Mounts, Metric Mounts, Motor Wraps, and Hand Crank Option
Coupling	Three (3) different styles available
Waycover Material	Hypilon Polyester Bellows mounted to carriage & end plates

Specifications subject to change without notice

Dimensions & Specifications

- Without Cover Plates -

Model Number	Travel Length inches (mm)	Table Dimensions inches (mm)		Mounting Dimensions inches (mm)		Screw Length inches (mm)	Table Weight lbs (kgf) ⁽¹⁾
		A	B	C	M		
17x606-CP0	6 (150)	12.125 (308,0)	16.688 (423,9)	3	8	16.00 (406)	14.2 (6,4)
17x612-CP0	12 (300)	18.125 (460,4)	22.688 (576,3)	5	12	22.00 (559)	16.0 (7,3)
17x618-CP0	18 (455)	24.125 (612,8)	28.688 (728,7)	7	16	28.00 (711)	17.8 (8,1)
17x624-CP0	24 (605)	30.125 (765,2)	34.688 (881,1)	9	20	34.00 (864)	19.6 (8,9)
17x630-CP0	30 (760)	36.125 (917,6)	40.688 (1033,5)	11	24	40.00 (1016)	21.4 (9,7)
17x636-CP0	36 (910)	42.125 (1070,0)	46.688 (1185,9)	13	28	46.00 (1168)	23.2 (10,5)
17x642-CP0	42 (1060)	48.125 (1222,4)	52.688 (1338,3)	15	32	52.00 (1321)	25.0 (11,3)
17x648-CP0	48 (1215)	54.125 (1374,8)	58.688 (1490,7)	17	36	58.00 (1473)	26.8 (12,2)
17x654-CP0	54 (1370)	60.125 (1527,1)	64.688 (1643,0)	19	40	64.00 (1625)	28.6 (13,0)
17x660-CP0	60 (1520)	66.125 (1679,6)	70.688 (1795,5)	21	44	70.00 (1778)	30.4 (13,8)

- {

 x = 2; Carriage has 2 bearings; Carriage weight = 2.5 lbs. (1,13 kg)
- }

 x = 4; Carriage has 4 bearings; Carriage weight = 3.3 lbs. (1,50 kg)

Footnotes:

- (1) Weight shown is with a 0.625 inch (16 mm) diameter screw, a NEMA 23 motor mount [0.42 lbs (0,19 kg)], a C100 style [0.09 lbs (0,04 kg)] coupling, and a 2 bearing carriage. When using a 0.750 inch (20 mm) diameter screw add 0.042 lbs per inch (0,00075 kg per mm) of screw length for a given model number. When using a 4 bearing carriage add 0.8 lbs (0,36 kg) to each value.

Dimensions

- Without Cover Plates -

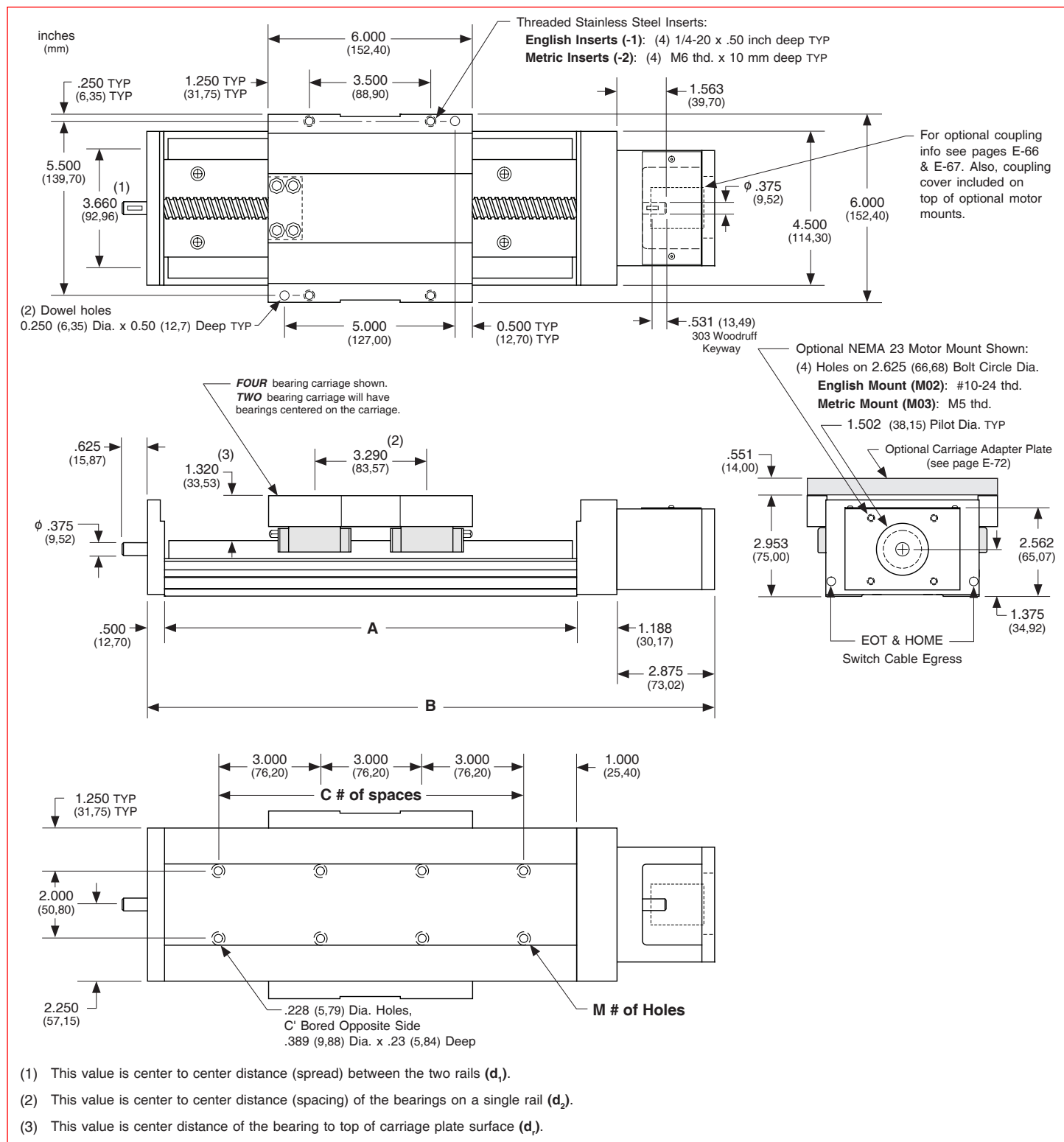

Specifications subject to change without notice

Dimensions & Specifications

- With Top Cover Plate Only -

Model Number	Travel Length inches (mm)	Table Dimensions inches (mm)		Mounting Dimensions inches (mm)		Screw Length inches (mm)	Table Weight ⁽¹⁾ lbs (kg)
		A	B	C	M		
17x606-CP1	6 (150)	12.125 (308,0)	16.688 (423,9)	3	8	16.00 (406)	15.0 (6,8)
17x612-CP1	12 (300)	18.125 (460,4)	22.688 (576,3)	5	12	22.00 (559)	17.2 (7,8)
17x618-CP1	18 (455)	24.125 (612,8)	28.688 (728,7)	7	16	28.00 (711)	19.4 (8,8)
17x624-CP1	24 (605)	30.125 (765,2)	34.688 (881,1)	9	20	34.00 (864)	21.6 (9,8)
17x630-CP1	30 (760)	36.125 (917,6)	40.688 (1033,5)	11	24	40.00 (1016)	23.8 (10,8)
17x636-CP1	36 (910)	42.125 (1070,0)	46.688 (1185,9)	13	28	46.00 (1168)	26.0 (11,8)
17x642-CP1	42 (1060)	48.125 (1222,4)	52.688 (1338,3)	15	32	52.00 (1321)	28.2 (12,8)
17x648-CP1	48 (1215)	54.125 (1374,8)	58.688 (1490,7)	17	36	58.00 (1473)	30.4 (13,8)
17x654-CP1	54 (1370)	60.125 (1527,1)	64.688 (1643,0)	19	40	64.00 (1625)	32.6 (14,8)
17x660-CP1	60 (1520)	66.125 (1679,6)	70.688 (1795,5)	21	44	70.00 (1778)	34.8 (15,8)

- x = 2; Carriage has 2 bearings; Carriage weight = 2.5 lbs. (1,13 kg)
- x = 4; Carriage has 4 bearings; Carriage weight = 3.3 lbs. (1,50 kg)

Footnotes:

(1) Weight shown is with a 0.625 inch (16 mm) diameter screw, a NEMA 23 motor mount [0.42 lbs (0,19 kg)], a C100 style [0.09 lbs (0,04 kg)] coupling, and a 2 bearing carriage. When using a 0.750 inch (20 mm) diameter screw add 0.042 lbs per inch (0,00075 kg per mm) of screw length for a given model number. When using a 4 bearing carriage add 0.8 lbs (0,36 kg) to each value.

Dimensions

- With Top Cover Plate Only -

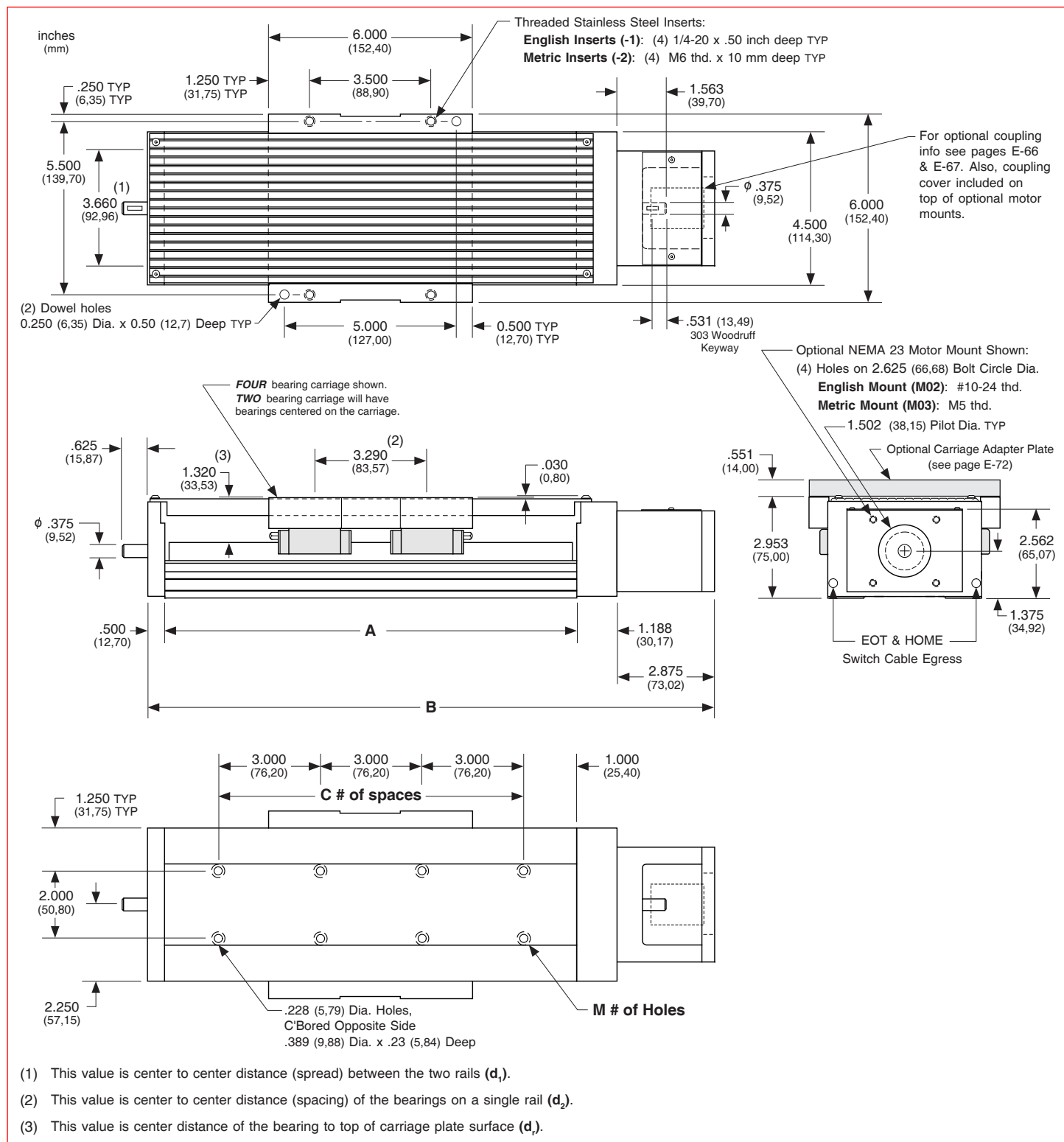

Dimensions & Specifications

- With Top & Side Cover Plates -

Model Number	Travel Length inches (mm)	Table Dimensions inches (mm)		Mounting Dimensions inches (mm)		Screw Length inches (mm)	Table ⁽¹⁾ Weight lbs (kg)
		A	B	C	M		
17x606-CP2	6 (150)	12.125 (308,0)	16.688 (423,9)	3	8	16.00 (406)	16.6 (7,5)
17x612-CP2	12 (300)	18.125 (460,4)	22.688 (576,3)	5	12	22.00 (559)	19.1 (8,7)
17x618-CP2	18 (455)	24.125 (612,8)	28.688 (728,7)	7	16	28.00 (711)	21.7 (9,8)
17x624-CP2	24 (605)	30.125 (765,2)	34.688 (881,1)	9	20	34.00 (864)	24.3 (11,0)
17x630-CP2	30 (760)	36.125 (917,6)	40.688 (1033,5)	11	24	40.00 (1016)	26.8 (12,2)
17x636-CP2	36 (910)	42.125 (1070,0)	46.688 (1185,9)	13	28	46.00 (1168)	29.4 (13,3)
17x642-CP2	42 (1060)	48.125 (1222,4)	52.688 (1338,3)	15	32	52.00 (1321)	32.0 (14,5)
17x648-CP2	48 (1215)	54.125 (1374,8)	58.688 (1490,7)	17	36	58.00 (1473)	34.5 (15,6)
17x654-CP2	54 (1370)	60.125 (1527,1)	64.688 (1643,0)	19	40	64.00 (1625)	37.1 (16,8)
17x660-CP2	60 (1520)	66.125 (1679,6)	70.688 (1795,5)	21	44	70.00 (1778)	39.6 (17,9)

- x = 2; Carriage has 2 bearings; Carriage weight = 2.5 lbs. (1,13 kg)
- x = 4; Carriage has 4 bearings; Carriage weight = 3.3 lbs. (1,50 kg)

Footnotes:

(1) Weight shown is with a 0.625 inch (16 mm) diameter screw, a NEMA 23 motor mount [0.42 lbs (0,19 kg)], a C100 style [0.09 lbs (0,04 kg)] coupling, and a 2 bearing carriage. When using a 0.750 inch (20 mm) diameter screw add 0.042 lbs per inch (0,00075 kg per mm) of screw length for a given model number. When using a 4 bearing carriage add 0.8 lbs (0,36 kg) to each value.

Dimensions

- With Top & Side Cover Plates -

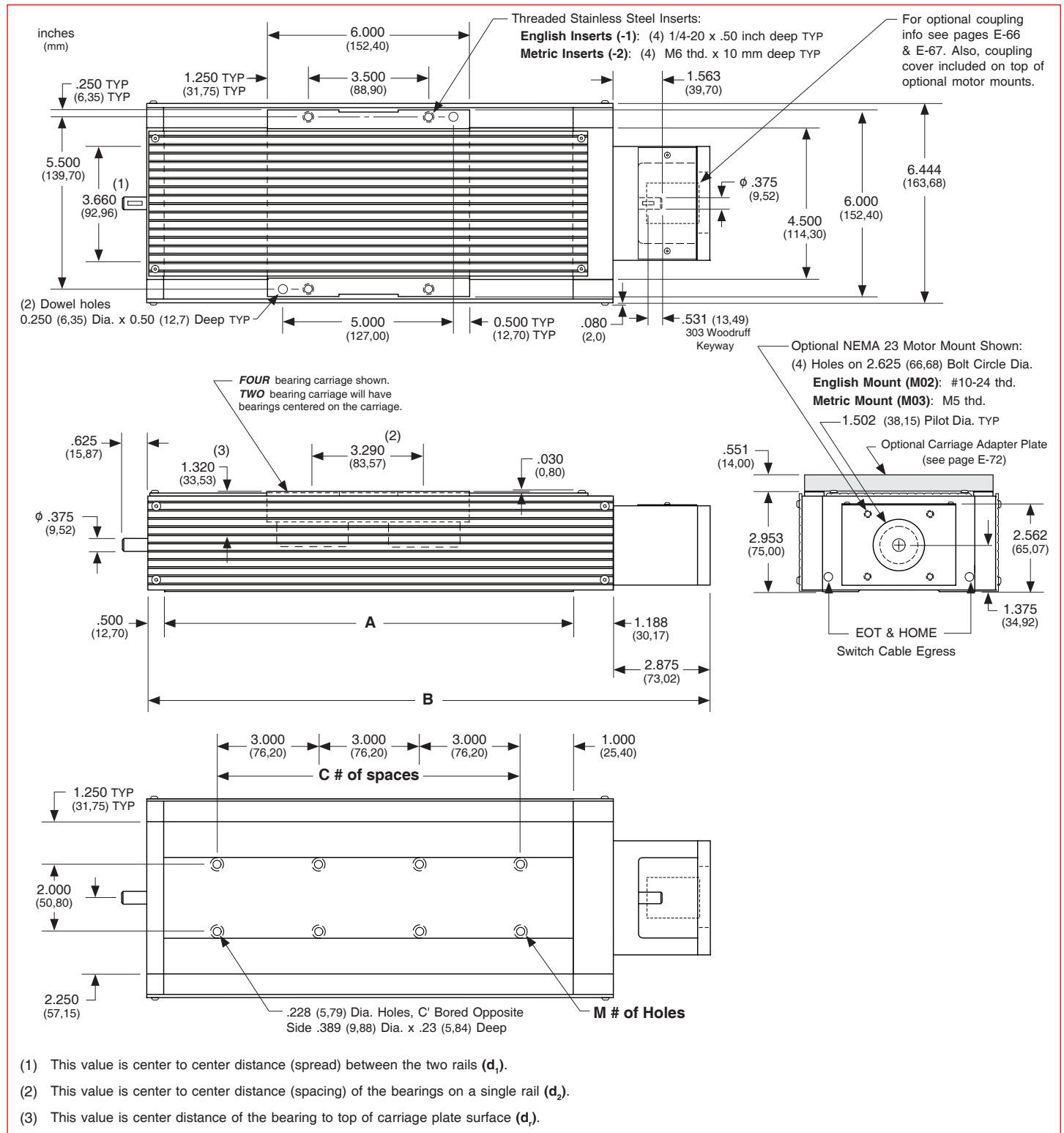

Dimensions & Specifications

- With Waycovers -

Model Number	Travel Length inches (mm)	Table Dimensions inches (mm)		Mounting Dimensions inches (mm)		Screw Length inches (mm)	Table ⁽¹⁾ Weight lbs (kg)
		A	B	C	M		
17x603-WC1	3.7 (94)	12.125 (308,0)	16.688 (423,9)	3	8	16.00 (406)	14.8 (6,7)
17x608-WC1	8.0 (203)	18.125 (460,4)	22.688 (576,3)	5	12	22.00 (559)	16.8 (7,6)
17x612-WC1	12.8 (325)	24.125 (612,8)	28.688 (728,7)	7	16	28.00 (711)	18.8 (8,5)
17x617-WC1	17.5 (444)	30.125 (765,2)	34.688 (881,1)	9	20	34.00 (864)	20.9 (9,5)
17x622-WC1	22.0 (555)	36.125 (917,6)	40.688 (1033,5)	11	24	40.00 (1016)	22.7 (10,3)
17x628-WC1	28.0 (710)	42.125 (1070,0)	46.688 (1185,9)	13	28	46.00 (1168)	24.7 (11,2)
17x632-WC1	32.5 (825)	48.125 (1222,4)	52.688 (1338,3)	15	32	52.00 (1321)	26.7 (12,1)
17x637-WC1	37.0 (935)	54.125 (1374,8)	58.688 (1490,7)	17	36	58.00 (1473)	28.7 (13,0)
17x641-WC1	41.5 (1050)	60.125 (1527,1)	64.688 (1643,0)	19	40	64.00 (1625)	30.8 (14,0)
17x647-WC1	47.5 (1205)	66.125 (1679,6)	70.688 (1795,5)	21	44	70.00 (1778)	33.0 (15,0)

- x = 2; Carriage has 2 bearings; Carriage weight = 2.5 lbs. (1,13 kg)
- x = 4; Carriage has 4 bearings; Carriage weight = 3.3 lbs. (1,50 kg)

Footnotes:

(1) Weight shown is with a 0.625 inch (16 mm) diameter screw, a NEMA 23 motor mount [0.42 lbs (0,19 kg)], a C100 style [0.09 lbs (0,04 kg)] coupling, and a 2 bearing carriage. When using a 0.750 inch (20 mm) diameter screw add 0.042 lbs per inch (0,00075 kg per mm) of screw length for a given model number. When using a 4 bearing carriage add 0.8 lbs (0,36 kg) to each value.

Dimensions

- With Waycovers -

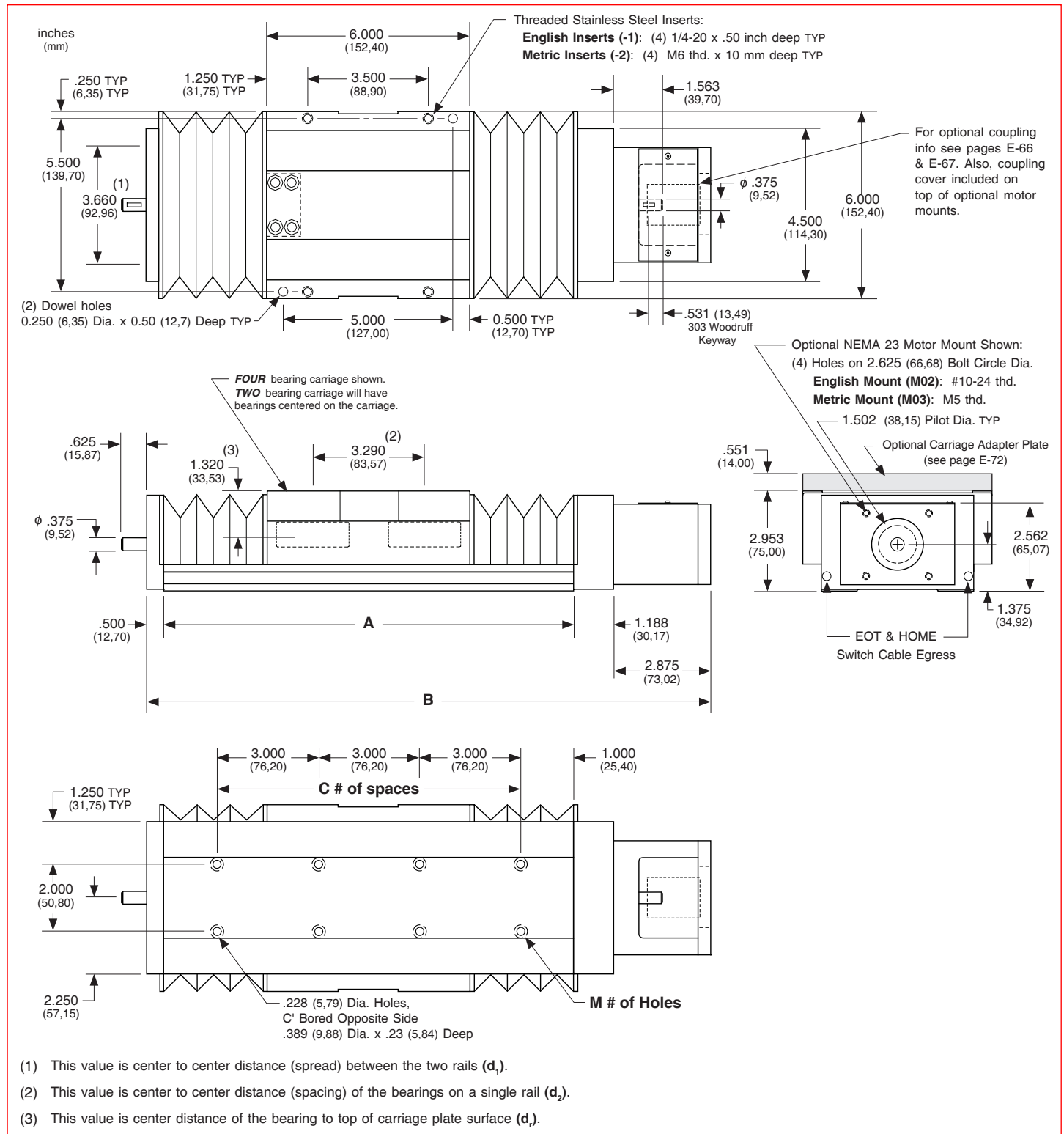

Note: Any 160, 170, or 180 series table can be mounted on top of a second 160, 170 or 180 series table, in order to create X-Y multiple axis configurations. See page E-72 for optional carriage adapter plate information or contact *LINTECH* for details.

17 **6** **12** **06** - **CP1** - **1** - **S005** - **M02** - **C155** - **L01** - **E00** - **B00**

Table Series

Number of Bearings

4 - 4 bearings **6** - 6 bearings

Carriage Length

12 - 12 inches

Travel Length (see pages E-20, E-22, E-24 & E-26)

06 - 3 to 54 inches

Cover Plate

CP0 - no cover plates **CP1** - top cover plate only **CP2** - top & side cover plates **WC1** - waycovers

Carriage Inserts (see pages E-21, E-23, E-25 & E-27)

1 - English mount **2** - Metric mount

Screw Options (see pages E-30 to E-35)

<i>Rolled ball screws</i>	<i>Rolled ball screws</i>	<i>Precision ball screws</i>
S005 - .625 x .200 NPL	S017 - .750 x .500 NPL	S114 - .625 x .200 NPL
S006 - .625 x .200 PL	S018 - .750 x .500 PL	S115 - .625 x .200 PL
S007 - .625 x .200 NPL(T)	S019 - .750 x .500 NPL(T)	S116 - 16 x 5 NPL
S008 - .625 x .200 PL(T)	S020 - .750 x .500 PL(T)	S117 - 16 x 5 PL
S009 - .625 x 1.000 NPL		S118 - 16 x 10 NPL
S010 - .625 x 1.000 PL	<i>Ground ball screws</i>	S119 - 16 x 10 PL
S011 - .625 x 1.000 NPL(T)	S212 - .625 x .200 PL	S120 - 16 x 16 NPL
S012 - .625 x 1.000 PL(T)	S213 - .625 x .500 PL	S121 - 16 x 16 PL
S013 - .750 x .200 NPL	S214 - 16 x 5 PL	S122 - .750 x .200 NPL
S014 - .750 x .200 PL	S215 - 16 x 16 PL	S123 - .750 x .200 PL
S015 - .750 x .200 NPL(T)	<i>Rolled acme screws</i>	S124 - 20 x 5 NPL
S016 - .750 x .200 PL(T)	S300 - .625 x .100 NPL	S125 - 20 x 5 PL
	S301 - .625 x .100 PL	S128 - 20 x 20 NPL
S999 - other	S302 - .625 x .200 NPL	S129 - 20 x 20 PL
	S303 - .625 x .200 PL	

Motor Mount (see pages E-21, E-23, E-25, E-27, E-68 & E-69)

M00 - none	M02 - NEMA 23 mount (E)	M06 - NEMA 23 (RH) wrap
M01 - hand crank	M03 - NEMA 23 mount (M)	M07 - NEMA 23 (LH) wrap
M20 to M98 - see Website	M04 - NEMA 34 mount (E)	M08 - NEMA 34 (RH) wrap
M99 - other	M05 - NEMA 34 mount (M)	M09 - NEMA 34 (LH) wrap

Coupling Options (see pages E-66 to E-67)

C000 - none	C025 to C030 - C100	C130 to C136 - H100	C407 to C415 - G100
C999 - other	C048 to C069 - C125	C155 to C184 - H131	C435 to C464 - G126
		C190 to C200 - H163	C470 to C514 - G158

Limit & Home Switches (see pages E-63 to E-65)

L00 - no switches	Mechanical	Reed	Hall	Prox (NPN)	Prox (PNP)
L99 - other	L01	L04	L07	L10	L13
	L02	L05	L08	L11	L14
	L03	L06	L09	L12	L15

Encoder Options (see page E-71)

E00 - none	E02 - rotary (1000 lines/rev)	E10 - linear (2500 lines/inch)	E99 - other
E01 - rotary (500 lines/rev)	E03 - rotary (1270 lines/rev)	E11 - linear (250 lines/mm)	

Power-off Brakes (see page E-70)

B00 - none	B01 - 24 VDC	B02 - 90 VDC	B99 - other	(E) - English Interface	(NPL) - Non Preloaded
				(LH) - Left Hand	(PL) - Preloaded
				(M) - Metric Interface	(RH) - Right Hand
					(T) - Turcite Nut

Specifications subject to change without notice

Specifications

Load Capacities		Four (4) Bearing Carriage	Six (6) Bearing Carriage
Dynamic Horizontal	2 million inches (50 km) of travel	7,780 lbs (3530 kgf)	11,670 lbs (5290 kgf)
Dynamic Horizontal	100 million inches (2540 km) of travel	2,090 lbs (948 kgf)	3,135 lbs (1420 kgf)
Static Horizontal		11,640 lbs (5280 kgf)	17,460 lbs (7920 kgf)
Dynamic Roll Moment	2 million inches (50 km) of travel	1,025 ft-lbs (1390 N-m)	1,540 ft-lbs (2085 N-m)
Dynamic Roll Moment	100 million inches (2540 km) of travel	275 ft-lbs (370 N-m)	410 ft-lbs (555 N-m)
Static Roll Moment		1,830 ft-lbs (2480 N-m)	2,750 ft-lbs (3725 N-m)
Dyn. Pitch & Yaw Moment	2 million inches (50 km) of travel	2,160 ft-lbs (2925 N-m)	2,235 ft-lbs (3030 N-m)
Dyn. Pitch & Yaw Moment	100 million inches (2540 km) of travel	580 ft-lbs (785 N-m)	600 ft-lbs (810 N-m)
Static Pitch & Yaw Moment		3,860 ft-lbs (5230 N-m)	3,980 ft-lbs (5395 N-m)
Each Bearing Dyn. Capacity	2 million inches (50 km) of travel	1,945 lbs (882 kgf)	1,945 lbs (882 kgf)
Each Bearing Dyn. Capacity	100 million inches (2540 km) of travel	525 lbs (238 kgf)	525 lbs (238 kgf)
Each Bearing Static Load Capacity		2,910 lbs (1320 kgf)	2,910 lbs (1320 kgf)
Thrust Force Capacity	10 million screw revolutions	895 lbs (406 kgf)	895 lbs (406 kgf)
Thrust Force Capacity	500 million screw revolutions	240 lbs (109 kgf)	240 lbs (109 kgf)
Maximum Acceleration		772 in/sec ² (19,6 m/sec ²)	772 in/sec ² (19,6 m/sec ²)
d₁	Center to center distance (spread) between the two rails	3.660 in (92,96 mm)	3.660 in (92,96 mm)
d₂	Center to center distance (spacing) of the bearings on a single rail	9.290 in (235,97 mm)	4.645 in (117,98 mm)
d_r	Center distance of the bearing to top of carriage plate surface	1.320 in (33,53 mm)	1.320 in (33,53 mm)

Other	For Two (2) & Four (4) Bearing Carriages
Table Material	Base, Carriage, End Plates & Cover Plate Option - 6061 anodized aluminum
Linear Rail Material	Case Hardened Steel
Screw Material (see pages E-30 to E-35)	Acme Screw - Stainless Steel
Screw Material (see pages E-30 to E-35)	Rolled Ball, Precision Ball, & Ground Ball - Case Hardened Steel
Unidirectional Repeatability	+/- 0.0002 in (5 microns)
Bidirectional Repeatability	+/- 0.0002 in (5 microns) to +/- 0.0082 in (208 microns) - depends on selected screw
Straightness	< 0.00016 in/in (< 4,06 microns/25mm)
Flatness	< 0.00016 in/in (< 4,06 microns/25mm)
Orthogonality (multi-axis systems)	< 30 arc-seconds
Friction Coefficient	< 0.01
Motor Mount	NEMA 23 & 34 Mounts, Metric Mounts, Motor Wraps, and Hand Crank Option
Coupling	Three (3) different styles available
Waycover Material	Hypilon Polyester Bellows mounted to carriage & end plates

Specifications subject to change without notice

Dimensions & Specifications

- Without Cover Plates -

Model Number	Travel Length inches (mm)	Table Dimensions inches (mm)		Mounting Dimensions inches (mm)		Screw Length inches (mm)	Table ⁽¹⁾ Weight
		A	B	C	M		lbs (kgf)
17x1206-CP0	6 (150)	18.125 (460,4)	22.688 (576,3)	5	12	22.00 (559)	18.5 (8,4)
17x1212-CP0	12 (300)	24.125 (612,8)	28.688 (728,7)	7	16	28.00 (711)	20.3 (9,2)
17x1218-CP0	18 (455)	30.125 (765,2)	34.688 (881,1)	9	20	34.00 (864)	22.1 (10,2)
17x1224-CP0	24 (605)	36.125 (917,6)	40.688 (1033,5)	11	24	40.00 (1016)	23.9 (10,8)
17x1230-CP0	30 (760)	42.125 (1070,0)	46.688 (1185,9)	13	28	46.00 (1168)	25.7 (11,7)
17x1236-CP0	36 (910)	48.125 (1222,4)	52.688 (1338,3)	15	32	52.00 (1321)	27.5 (12,5)
17x1242-CP0	42 (1060)	54.125 (1374,8)	58.688 (1490,7)	17	36	58.00 (1473)	29.3 (13,3)
17x1248-CP0	48 (1215)	60.125 (1527,2)	64.688 (1643,1)	19	40	64.00 (1626)	31.2 (14,2)
17x1254-CP0	54 (1370)	66.125 (1679,6)	70.688 (1795,5)	21	44	70.00 (1778)	33.0 (15,0)

- ┌ x = 4; Carriage has 4 bearings; Carriage weight = 5.0 lbs. (2,27 kg)
- └ x = 6; Carriage has 6 bearings; Carriage weight = 5.8 lbs. (2,63 kg)

Footnotes:

(1) Weight shown is with a 0.625 inch (16 mm) diameter screw, a NEMA 23 motor mount [0.42 lbs (0,19 kg)], a C100 style [0.09 lbs (0,04 kg)] coupling, and a 4 bearing carriage. When using a 0.750 inch (20 mm) diameter screw add 0.042 lbs per inch (0,00075 kg per mm) of screw length for a given model number. When using a 6 bearing carriage add 0.8 lbs (0,36 kg) to each value.

Dimensions

- Without Cover Plates -

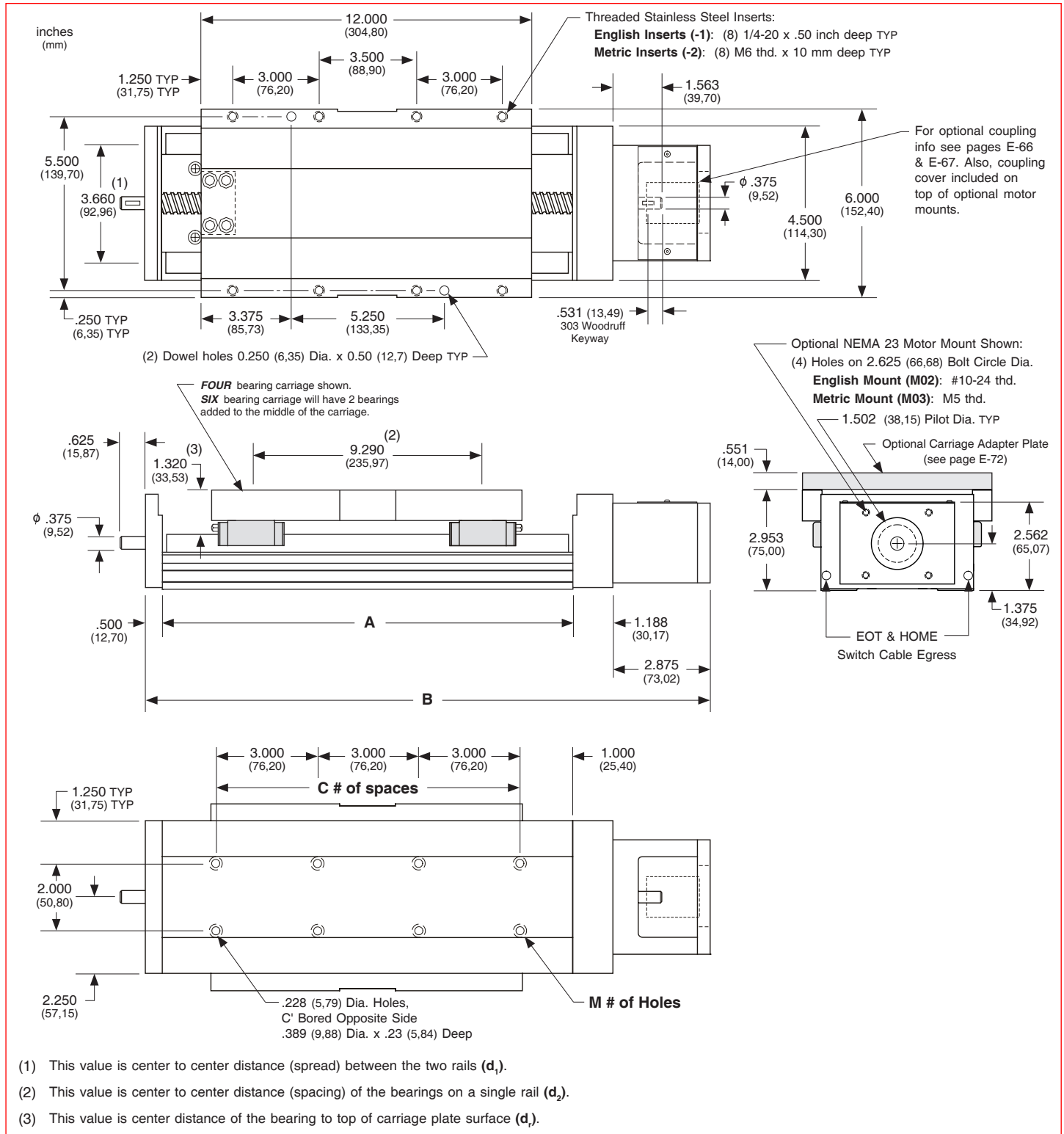

Note: Any 160, 170, or 180 series table can be mounted on top of a second 160, 170 or 180 series table, in order to create X-Y multiple axis configurations. See page E-72 for optional carriage adapter plate information or contact *LINTECH* for details.

Dimensions & Specifications

- With Top Cover Plate Only -

Model Number	Travel Length inches (mm)	Table Dimensions inches (mm)		Mounting Dimensions inches (mm)		Screw Length inches (mm)	Table ⁽¹⁾ Weight
		A	B	C	M		lbs (kgf)
17x1206-CP1	6 (150)	18.125 (460,4)	22.688 (576,3)	5	12	22.00 (559)	19.7 (8,9)
17x1212-CP1	12 (300)	24.125 (612,8)	28.688 (728,7)	7	16	28.00 (711)	21.9 (9,9)
17x1218-CP1	18 (455)	30.125 (765,2)	34.688 (881,1)	9	20	34.00 (864)	24.1 (10,9)
17x1224-CP1	24 (605)	36.125 (917,6)	40.688 (1033,5)	11	24	40.00 (1016)	26.3 (11,9)
17x1230-CP1	30 (760)	42.125 (1070,0)	46.688 (1185,9)	13	28	46.00 (1168)	28.5 (12,9)
17x1236-CP1	36 (910)	48.125 (1222,4)	52.688 (1338,3)	15	32	52.00 (1321)	30.7 (13,9)
17x1242-CP1	42 (1060)	54.125 (1374,8)	58.688 (1490,7)	17	36	58.00 (1473)	32.9 (14,9)
17x1248-CP1	48 (1215)	60.125 (1527,2)	64.688 (1643,1)	19	40	64.00 (1626)	35.1 (15,9)
17x1254-CP1	54 (1370)	66.125 (1679,6)	70.688 (1795,5)	21	44	70.00 (1778)	37.3 (16,9)

- ┌ x = 4; Carriage has 4 bearings; Carriage weight = 5.0 lbs. (2,27 kg)
- └ x = 6; Carriage has 6 bearings; Carriage weight = 5.8 lbs. (2,63 kg)

Footnotes:

(1) Weight shown is with a 0.625 inch (16 mm) diameter screw, a NEMA 23 motor mount [0.42 lbs (0,19 kg)], a C100 style [0.09 lbs (0,04 kg)] coupling, and a 4 bearing carriage. When using a 0.750 inch (20 mm) diameter screw add 0.042 lbs per inch (0,00075 kg per mm) of screw length for a given model number. When using a 6 bearing carriage add 0.8 lbs (0,36 kg) to each value.

Dimensions

- With Top Cover Plate Only -

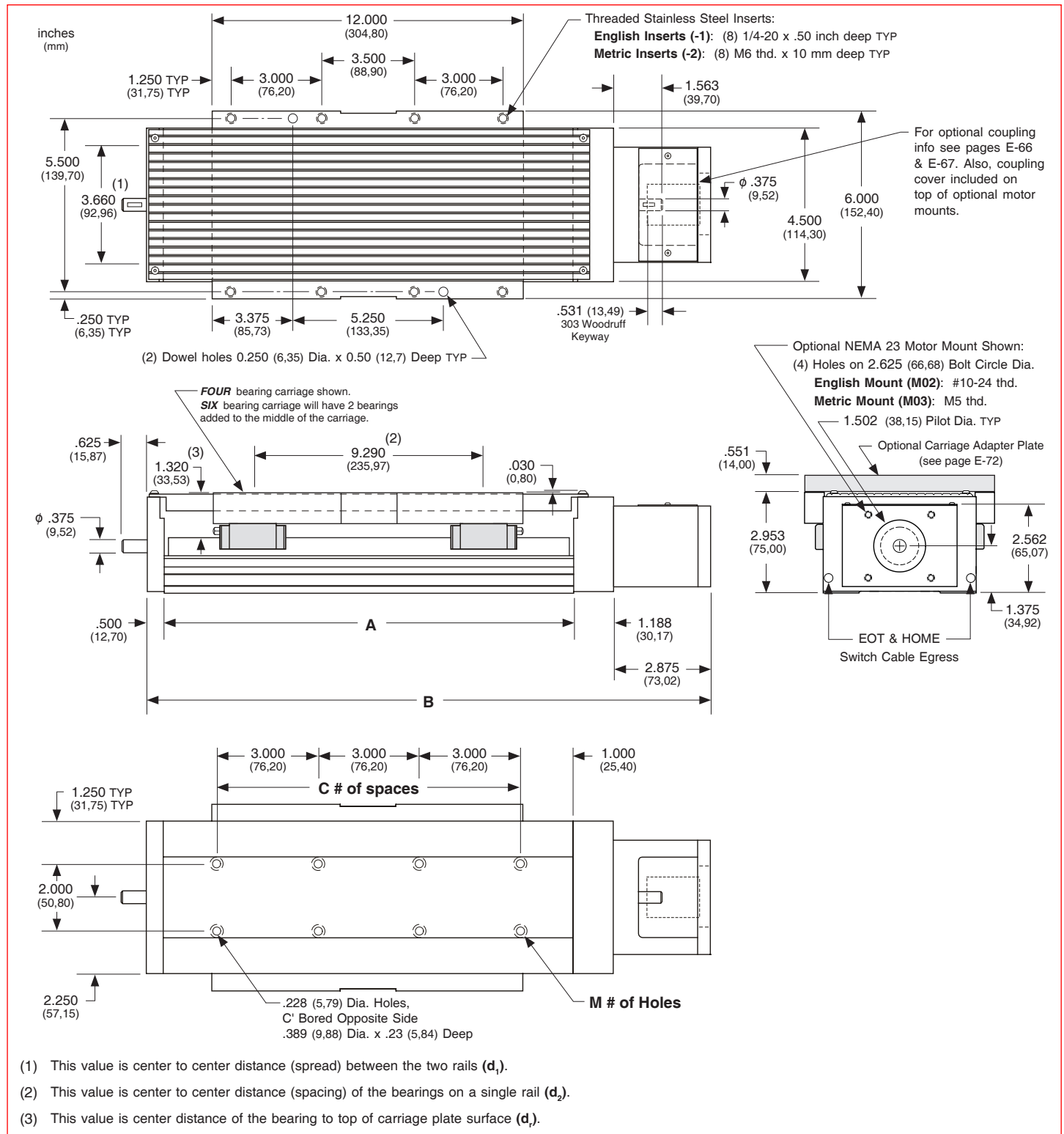

Dimensions & Specifications

- With Top & Side Cover Plates -

Model Number	Travel Length inches (mm)	Table Dimensions inches (mm)		Mounting Dimensions inches (mm)		Screw Length inches (mm)	Table ⁽¹⁾ Weight
		A	B	C	M		lbs (kgf)
17x1206-CP2	6 (150)	18.125 (460,4)	22.688 (576,3)	5	12	22.00 (559)	21.6 (9,8)
17x1212-CP2	12 (300)	24.125 (612,8)	28.688 (728,7)	7	16	28.00 (711)	24.2 (11,0)
17x1218-CP2	18 (455)	30.125 (765,2)	34.688 (881,1)	9	20	34.00 (864)	26.1 (11,8)
17x1224-CP2	24 (605)	36.125 (917,6)	40.688 (1033,5)	11	24	40.00 (1016)	28.7 (13,1)
17x1230-CP2	30 (760)	42.125 (1070,0)	46.688 (1185,9)	13	28	46.00 (1168)	31.3 (14,2)
17x1236-CP2	36 (910)	48.125 (1222,4)	52.688 (1338,3)	15	32	52.00 (1321)	34.5 (15,7)
17x1242-CP2	42 (1060)	54.125 (1374,8)	58.688 (1490,7)	17	36	58.00 (1473)	37.0 (16,8)
17x1248-CP2	48 (1215)	60.125 (1527,2)	64.688 (1643,1)	19	40	64.00 (1626)	39.6 (18,0)
17x1254-CP2	54 (1370)	66.125 (1679,6)	70.688 (1795,5)	21	44	70.00 (1778)	42.1 (19,1)

- ┌ x = 4; Carriage has 4 bearings; Carriage weight = 5.0 lbs. (2,27 kg)
- └ x = 6; Carriage has 6 bearings; Carriage weight = 5.8 lbs. (2,63 kg)

Footnotes:

(1) Weight shown is with a 0.625 inch (16 mm) diameter screw, a NEMA 23 motor mount [0.42 lbs (0,19 kg)], a C100 style [0.09 lbs (0,04 kg)] coupling, and a 4 bearing carriage. When using a 0.750 inch (20 mm) diameter screw add 0.042 lbs per inch (0,00075 kg per mm) of screw length for a given model number. When using a 6 bearing carriage add 0.8 lbs (0,36 kg) to each value.

Dimensions

- With Top & Side Cover Plates -

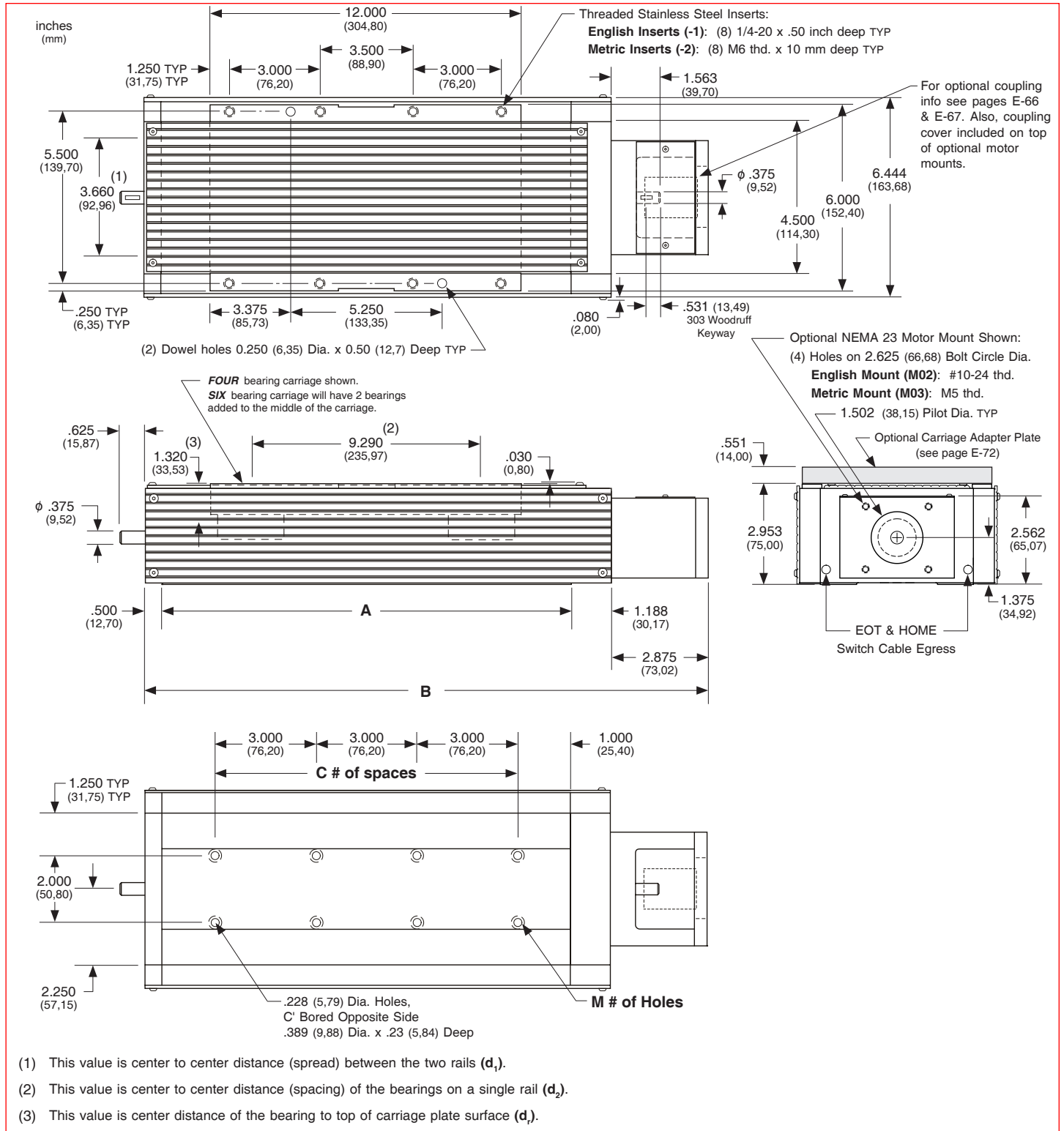

Note: Any 160, 170, or 180 series table can be mounted on top of a second 160, 170 or 180 series table, in order to create X-Y multiple axis configurations. See page E-72 for optional carriage adapter plate information or contact *LINTECH* for details.

Dimensions & Specifications

- With Waycovers -

Model Number	Travel Length inches (mm)	Table Dimensions inches (mm)		Mounting Dimensions inches (mm)		Screw Length inches (mm)	Table ⁽¹⁾ Weight lbs (kg)
		A	B	C	M		
17x1203-WC1	3.7 (94)	18.125 (460,4)	22.688 (576,3)	5	12	22.00 (559)	16.8 (7,6)
17x1208-WC1	8.0 (203)	24.125 (612,8)	28.688 (728,7)	7	16	28.00 (711)	18.8 (8,5)
17x1212-WC1	12.8 (444)	30.125 (765,2)	34.688 (881,1)	9	20	34.00 (864)	20.9 (9,5)
17x1217-WC1	17.5 (597)	36.125 (917,6)	40.688 (1033,5)	11	24	40.00 (1016)	22.7 (10,3)
17x1222-WC1	22.0 (555)	42.125 (1070,0)	46.688 (1185,9)	13	28	46.00 (1168)	24.7 (11,2)
17x1228-WC1	28.0 (710)	48.125 (1222,4)	52.688 (1338,3)	15	32	52.00 (1321)	26.7 (12,1)
17x1232-WC1	32.5 (825)	54.125 (1374,8)	58.688 (1490,7)	17	36	58.00 (1473)	28.7 (13,0)
17x1237-WC1	37.0 (935)	60.125 (1527,2)	64.688 (1643,1)	21	44	64.00 (1626)	30.9 (14,0)
17x1241-WC1	41.5 (1050)	66.125 (1679,6)	70.688 (1795,5)	21	44	70.00 (1778)	33.0 (15,0)

- x = 4; Carriage has 4 bearings; Carriage weight = 5.0 lbs. (2,27 kg)
- x = 6; Carriage has 6 bearings; Carriage weight = 5.8 lbs. (2,63 kg)

Footnotes:

(1) Weight shown is with a 0.625 inch (16 mm) diameter screw, a NEMA 23 motor mount [0.42 lbs (0,19 kg)], a C100 style [0.09 lbs (0,04 kg)] coupling, and a 2 bearing carriage. When using a 0.750 inch (20 mm) diameter screw add 0.042 lbs per inch (0,00075 kg per mm) of screw length for a given model number. When using a 4 bearing carriage add 0.8 lbs (0,36 kg) to each value.

Dimensions

- With Waycovers -

