

Nut Dimensions

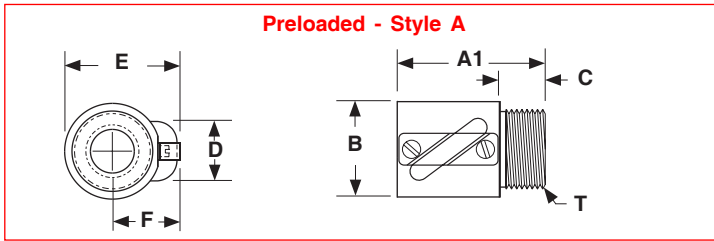

Nut Flange Dimensions

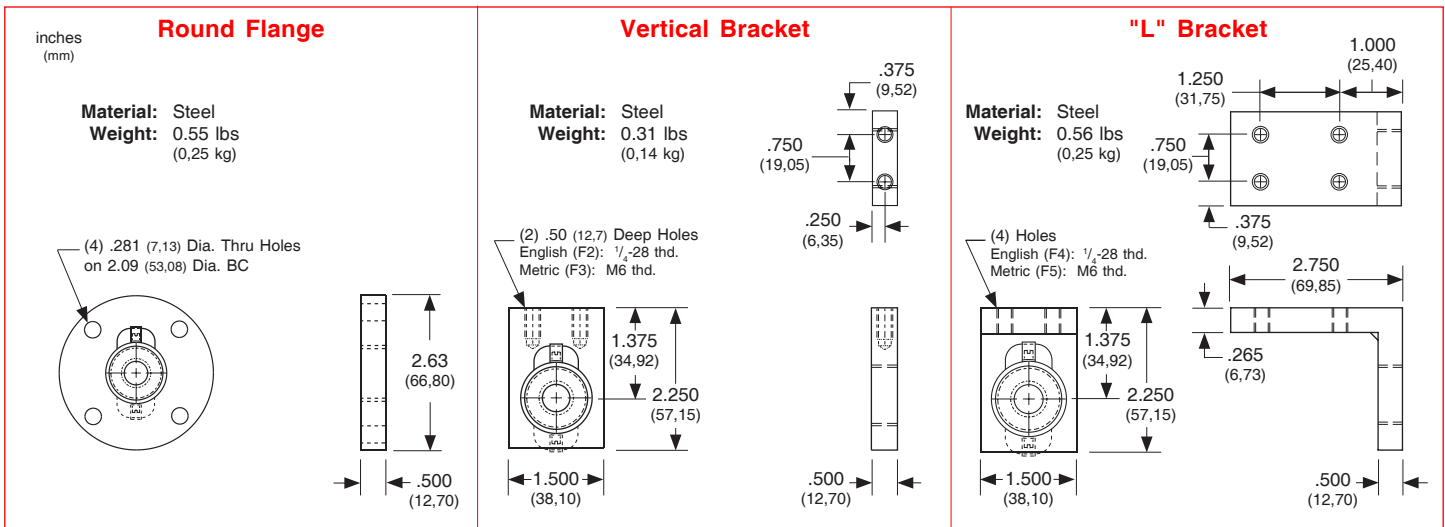

Model Number	Nut Style	Nut Dimensions inches (mm)							Nut Weight lbs (kg)
		A1 ⁽¹⁾	B	C	D	E	F	T - "V" Threads ⁽²⁾	
GS075020	A	1.780 (45,21)	1.378 (35,00)	0.500 (12,70)	1.063 (27,00)	1.674 (42,52)	0.985 (25,00)	1.173 - 18 UNS-2A (29,79 - 18 UNS-2A)	0.68 (0,31)
GS20M05M	A	1.780 (45,21)	1.378 (35,00)	0.500 (12,70)	1.063 (27,00)	1.674 (42,52)	0.985 (25,00)	1.173 - 18 UNS-2A (29,79 - 18 UNS-2A)	0.68 (0,31)
GS20M20M	A	2.370 (60,20)	1.418 (36,02)	0.500 (12,70)	1.103 (28,02)	1.772 (45,01)	1.063 (27,00)	1 1/4 - 16 UN-2A (31,75 - 16 UN-2A)	0.85 (0,39)

Footnotes:

- (1) The preload is achieved internal to the nut. Thus, the GS series preloaded nut is matched to the screw thread.
 (2) All flange threads are internal (Type 2B) to match the external nut threads.