

## Dimensions & Specifications

Model Number	Table Top Diameter inches (mm)	Table Top Weight lbs (kg)	Table Weight lbs (kg)
<b>406xxx-1</b>	5.480 (139,2)	3.0 (1,4)	13.5 (6,2)

- xxx = 030; 30 to 1 gear ratio
- xxx = 090; 90 to 1 gear ratio
- xxx = 180; 180 to 1 gear ratio
- xxx = 270; 270 to 1 gear ratio
- xxx = 360; 360 to 1 gear ratio

## Dimensions

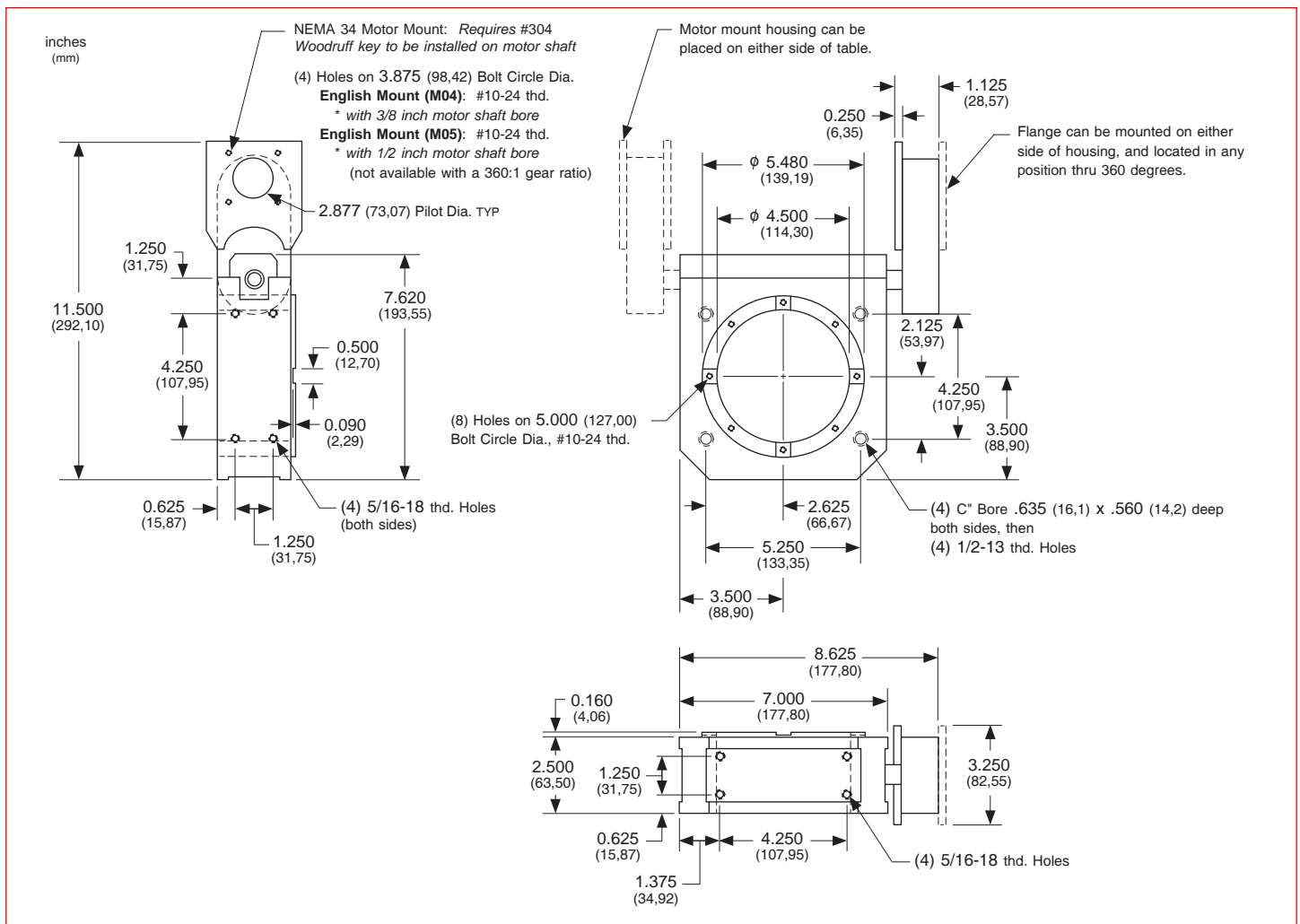

Specifications subject to change without notice