

Dimensions & Specifications

Model Number	Travel Length inches (mm)	Table Dimensions inches (mm)		Mounting Dimensions inches (mm)		Belt Weight ounces (kg)	Table (1) Weight lbs (kg)
		A	B	C	M		
18x6006-CP0	6 (150)	12.125 (308,0)	18.250 (463,6)	3	8	3.8 (0,11)	17.4 (7,9)
18x6012-CP0	12 (300)	18.125 (460,4)	24.250 (616,0)	5	12	5.3 (0,15)	19.6 (8,9)
18x6018-CP0	18 (455)	24.125 (612,8)	30.250 (768,4)	7	16	6.8 (0,19)	21.8 (9,9)
18x6024-CP0	24 (605)	30.125 (765,2)	36.250 (920,8)	9	20	8.3 (0,23)	24.0 (10,9)
18x6030-CP0	30 (760)	36.125 (917,6)	42.250 (1073,2)	11	24	9.8 (0,28)	26.2 (11,9)
18x6036-CP0	36 (910)	42.125 (1070,0)	48.250 (1225,6)	13	28	11.3 (0,32)	28.4 (12,9)
18x6042-CP0	42 (1060)	48.125 (1222,4)	54.250 (1378,0)	15	32	12.8 (0,36)	30.6 (13,9)
18x6048-CP0	48 (1215)	54.125 (1374,8)	60.250 (1530,4)	17	36	14.3 (0,41)	32.8 (14,9)
18x6054-CP0	54 (1370)	60.125 (1527,1)	66.250 (1682,7)	19	40	15.8 (0,45)	35.0 (15,9)
18x6060-CP0	60 (1520)	66.125 (1679,6)	72.250 (1835,2)	21	44	17.3 (0,49)	37.2 (16,9)
18x6072-CP0	72 (1825)	78.125 (1984,4)	84.250 (2140,0)	25	52	20.3 (0,58)	41.6 (18,9)
18x6084-CP0	84 (2130)	90.125 (2289,2)	96.250 (2444,8)	29	60	23.3 (0,66)	46.0 (20,9)
18x6096-CP0	96 (2435)	102.125 (2594,0)	108.250 (2749,6)	33	68	26.3 (0,75)	50.4 (22,9)
18x6108-CP0	108 (2740)	114.125 (2898,8)	120.250 (3054,4)	37	76	29.3 (0,83)	54.8 (24,9)

x = 2; Carriage has 2 bearings; Carriage weight = 2.5 lbs. (1,13 kg)
 x = 4; Carriage has 4 bearings; Carriage weight = 3.3 lbs. (1,50 kg)

Footnotes:

(1) Weight shown is with a 2 bearing carriage [2.5 lbs (1,13 kg)], a NEMA 23 motor mount [0.39 lbs (0,18 kg)], and a H100 style [0.08 lbs (0,04 kg)] coupling. When using a 4 bearing carriage add 0.8 lbs (0,36 kg) to each value.

- Without Cover Plates -

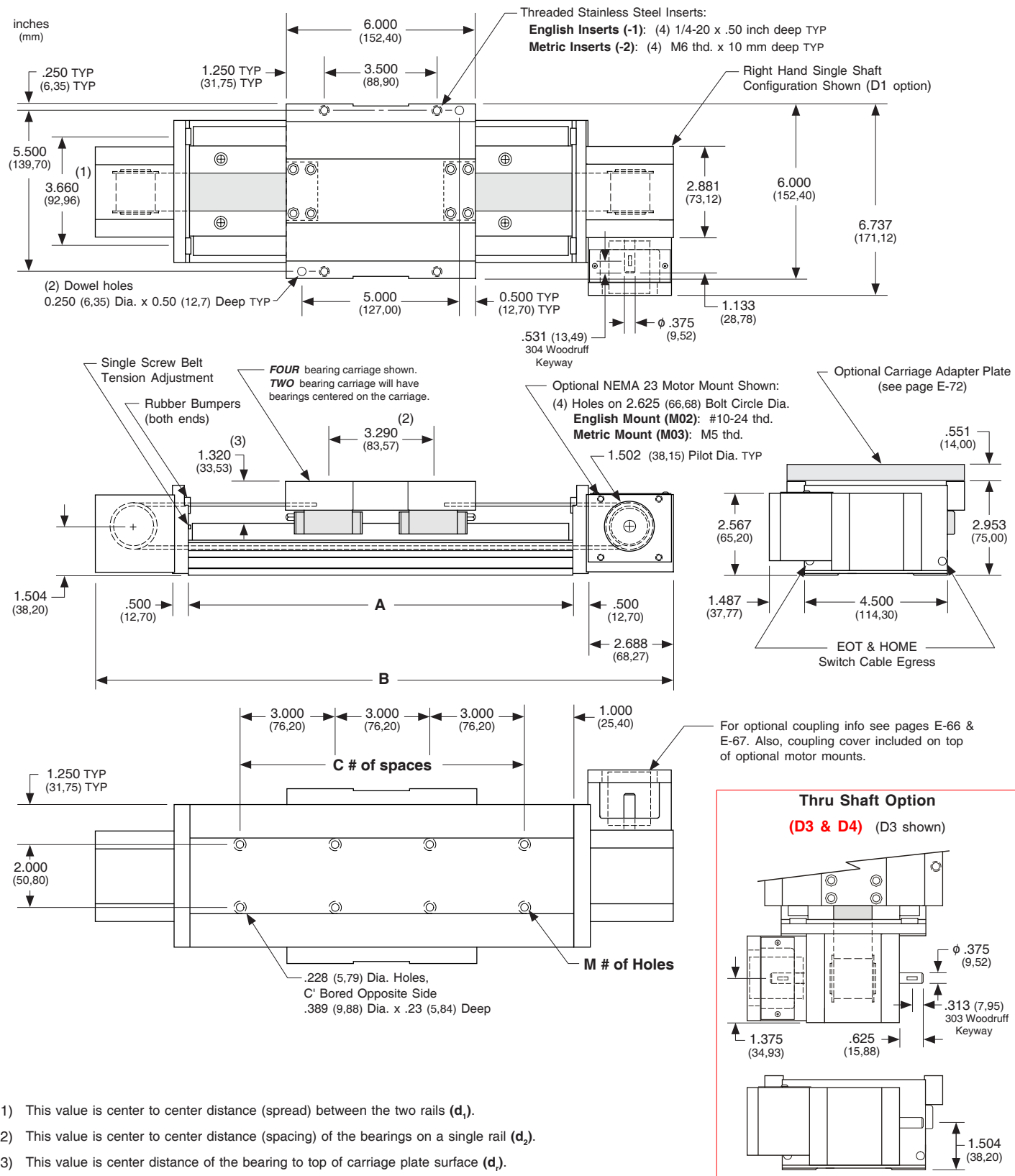

Note: Any 160, 170, or 180 series table can be mounted on top of a second 160, 170 or 180 series table, in order to create X-Y multiple axis configurations. See page E-72 for optional carriage adapter plate information or contact LINTTECH for details.