

Precision Shafting

LINTECH's precision "cut to length" 1060 carbon steel inch precision shafting is manufactured with the highest standards for surface finish, surface hardening, roundness and straightness. These manufacturing procedures provide a quality shaft with long life and optimum performance in today's demanding applications. Inch diameters are available from 0.25 to 2.0 inches in class L, S and N diameter tolerances. Metric diameters are available from 8 to 50 mm. Any length is available within .001 inch increments, up to the standard maximum stocked length.



ES End Shaft Support Blocks

LINTECH's aluminum and steel end support housings (ES series) provide a simple means to fix the ends of a shaft to a mounting surface. The ES-S series is manufactured from 1045 steel, while the ES-A series is manufactured from 6061-T6 aluminum.



ARS & LSRS Shaft Supports

LINTECH's aluminum and steel shaft supports provide a simple means to fix a shaft to a user mounting surface in an application that requires the shaft to be fully supported over its entire length. The ARS series is manufactured from 6061-T6 aluminum, while the low profile LSRS series is manufactured from C-1018 steel.



SA Shaft Assemblies

LINTECH's single Shaft Assembly (SA series) is a complete assembly which simplifies the use of a linear bearing in a mechanical positioning application. Each assembly has a steel shaft mounted to a black anodized, precision machined, aluminum support. The pre-drilled base mounting holes in the 6, 12, 18, and 24 inch supports allow for easy customer mounting. The SA assemblies come in standard lengths from 6 to 192 inches, and with shaft diameters from 0.50 to 2.00 inches.

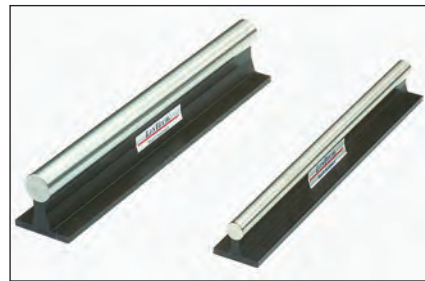

TRSA Shaft Assemblies

LINTECH's *TWIN RAIL*® Shaft Assembly (TRSA series) is a complete assembly which simplifies the use of a linear bearing in a mechanical positioning application. Two steel shafts are mounted and aligned on the common base, therefore eliminating the alignment process required for two separate shafts. The pre-drilled base mounting holes in the support allow for easy customer mounting. Each 6, 12, 18, and 24 inch aluminum support has two threaded holes at one end to assist in leveling the assembly. The TRSA comes in standard lengths from 6 to 192 inches, and with shaft diameters from 0.50 to 2.00 inches.



LBCA & LBOA Precision Linear Bearings

LINTECH's LBCA & LBOA offer an "all steel" linear bearing design. This provides for operation in high temperature environments (up to + 600^o F) and can offer a smoother operation when compared to the LBC & LBO style bearings for some applications.



LBC, LBO & Metric High Capacity Linear Bearings

LINTECH's high capacity linear bearings have a ball conforming outer race coupled with a self-aligning feature which allows for zero bearing clearance while maintaining smooth operation. The independently self-aligning outer bearing races insure smooth operation by allowing miss-alignment up to 1/2 degree in all directions. These linear bearings are available in "open" or "closed" styles. The closed style is available in 0.25 to 2.00 inch nominal diameters, while the open style is available in 0.50 to 2.00 inch nominal diameters. Metric style diameters are available from 16 mm to 50 mm.



SLBO, SLBC, DLBC & DLBO Pillow Blocks

LINTECH's SLBC and SLBO series have one linear bearing and two wiper seals per pillow block, and are self-aligning in all directions. The SLBO and DLBO series have a screw for pre-load adjustment to reduce the shaft and bearing clearance. *LINTECH's* DLBC and DLBO series have two linear bearings in one aluminum pillow block, separated by a wick that serves as an oil reservoir. Each pillow block housing provides a flat top surface for load mounting and alignment.

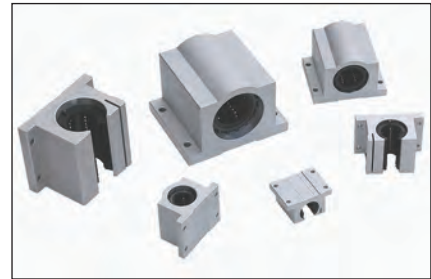

TRCA Carriage Assemblies

LINTECH's TRCA series, *TWIN RAIL*® carriage assemblies are pre-engineered assemblies which have either SLBO or DLBO pillow blocks mounted to a 6061-T6 aluminum, black anodized machined plate. The pillow blocks are pre-aligned and doweled to the carriage plate to match *LINTECH's* TRSA series shaft assemblies. The use of a TRCA carriage assembly and a TRSA shaft assembly reduces the process of mounting and aligning two shafts and pillow blocks. Each carriage surface is machined which allows for accurate mounting of customer loads, and are available with mounting holes with stainless steel inserts. Carriage assemblies are provided with pillow blocks for shaft diameters from 0.50 to 2.00 inches, and come in lengths from 6 to 30 inches.

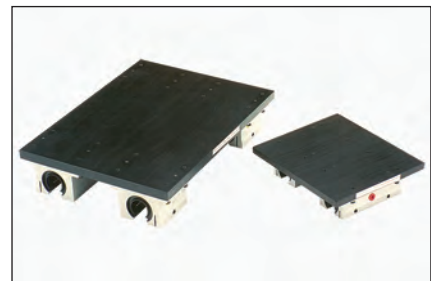

Options

LINTECH can provide many options which allow the user to customize a product for their application requirements. These include: metric shaft assemblies, tubular shafting, bearing locks, metric linear bearings, special finishes, custom *TWIN RAIL*® assembly widths and lengths, etc.. Contact the factory if a desired option is not shown in this catalog.

Precision Steel Shafts

LINTECH's precision shafting, SA and TRSA shaft assemblies use Rockwell 60-65C hardened and ground shafts. These high quality carbon steel shafts are accurately machined and heat treated for uniform hardness. They are also inspected for straightness, roundness, and smoothness. The high hardness and extremely smooth surface of the steel shafts creates an abrasion-resistant surface, which reduces material wear and system friction, while maintaining an optimal surface finish. Inch and Metric shaft diameters are available in different shaft tolerances.

Stainless Steel Shafts

For corrosion resistant applications, **LINTECH** provides 440C stainless steel shafts with the same shaft diameter tolerance, hardness depth, and straightness as our standard steel shafts. Stainless steel shafts are typically used in the chemical and food processing industries, for medical equipment in corrosive environments, or in strong oxidizing atmospheres where no lubricating oil is available.

Chrome Plated Shafts

LINTECH can also provide chrome plated precision shafting for those demanding applications that required a high level of corrosion resistance.

Shaft Diameter Tolerance

LINTECH shafts are precision ground to a very close diameter tolerance. This diameter tolerance is an extremely important factor when using **LINTECH** linear bearings. It assures a dependable fit, with proper clearance between a shaft and linear bearing.

Shaft Hardness

The hardness of a steel shaft is its ability to prevent nicks, indentations, or grooving. It is an important factor in determining the life of a linear bearing system in an application. The heat treatment process performed on all shafts assures uniform hardness in radial and axial directions.

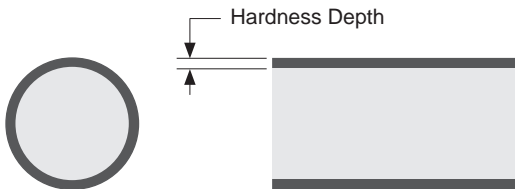

Shaft Straightness

The exceptional straightness of all shafts eliminate system binding when using a TRSA shaft assembly with a TRCA carriage assembly, and helps the alignment process when using two precision shafts, or SA shaft assemblies, in a parallel assembly application.

Shaft Supports

LINTECH ES end supports use 6061-T6 aluminum (-A), or 1045 steel (-S). These supports slide over the hardened shaft, and have a screw that is adjusted to clamp the support onto the shaft. The ARS series assembly support is manufactured from aluminum, while the low profile LSRS series is manufactured from C-1018 steel and functions the same as the ARS series, but has a smaller overall height.

ES-A Series

ES-S Series

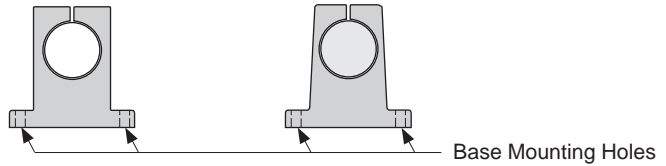

ARS Series

LSRS Series

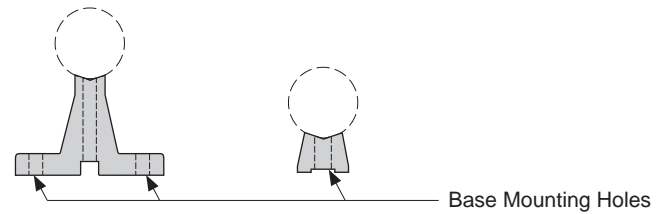

Shaft Assemblies

LINTECH shaft assemblies (SA and TRSA series) use 6061-T6 precision machined aluminum supports. These black anodized supports have pre-drilled base mounting holes that come in both single supports for the SA, and **TWIN RAIL**® supports for the TRSA. These precision machined supports come in 6, 12, 18, and 24 inch lengths, and can be combined for nearly unlimited assembly lengths.

SA Series - single rail supported assembly

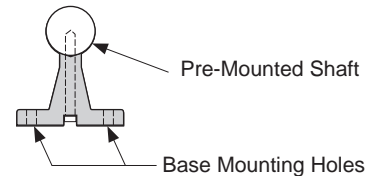

TRSA Series - **TWIN RAIL**® supported assembly

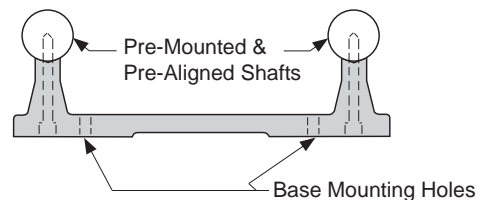

Precision Steel Linear Bearings

LINTECH's LBCA and LBCO precision steel linear bearings are manufactured with high quality steel that is hardened and precision ground. The recirculating precision ground bearing balls roll freely into and out of the load zone. The balls are guided through their recirculation path by a steel retainer and hardened sleeve. These bearings are used in high temperature applications and where self alignment is not required.

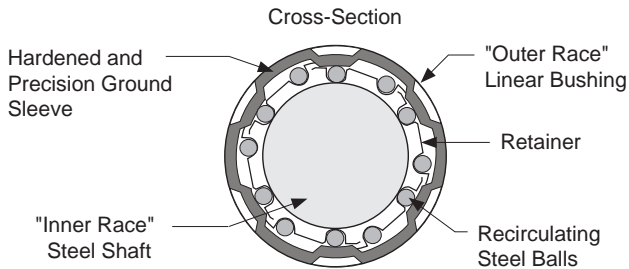

Pillow Blocks

LINTECH's SLBC, SLBO, DLBC and DLBO series pillow blocks use one or two, LBC or LBO, linear bearings with integral seals to obtain their long life, and high load capacity. The precision machined 6061-T6 aluminum pillow block mounting surface allows for accurate and easy mounting to a common carriage plate. The SLBO and DLBO pillow block models have an adjusting screw to permit adjustment of radial play between the "inner race" steel shaft and the "outer race" linear bearing. A retention pin is used to secure the linear bushing within the aluminum housing.

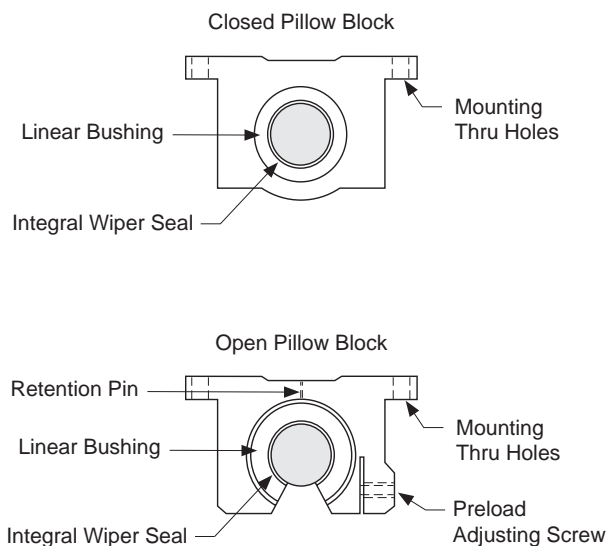

Self-Aligning Linear Bearings

LINTECH's LBC, LBC and Metric style linear bearings consists of a wear resistant, low friction, smooth, resilient, plastic ball retainer and plastic outer sleeve. The load carrying components of the linear bearing are precision machined, hardened steel bearing plates, and recirculating steel balls. There are longitudinal grooves along the inner surface of the steel bearing plates which contact the recirculating steel balls. The steel bearing plate is also designed slightly thicker in the middle than at either end. This tapered thickness along the bearing plate length allows the bearing plate to automatically align itself with the "inner race" steel shaft. This assures smooth entry and exit of the recirculating steel balls in and out of the load area, along with a more uniform load distribution within the linear bearing.

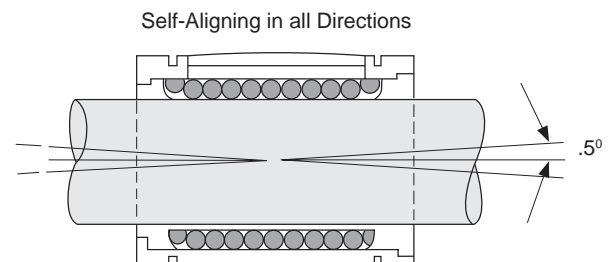
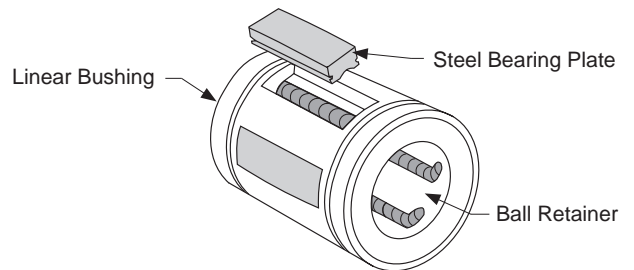
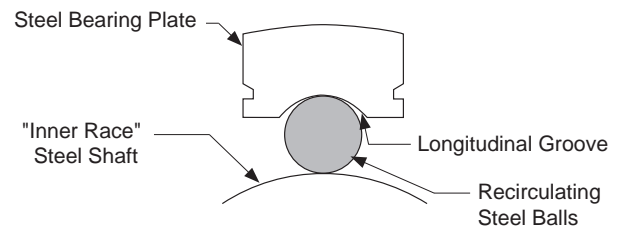
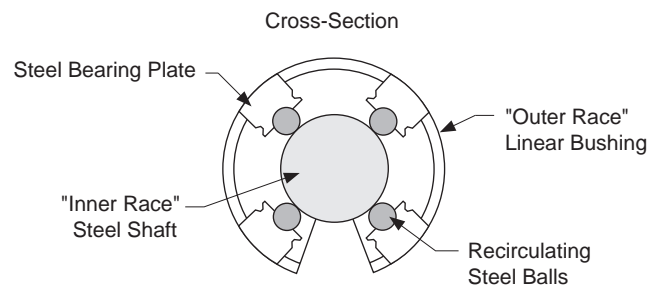

Travel Life

The rated life of a linear bearing, pillow block or carriage assembly is measured in inches (or km) of travel under a specified load. The failure of a linear bearing system occurs when the operating stresses from the rolling balls in the linear bushing cause material fatigue, resulting in flaking of the steel balls or steel shaft and/or grooving in the steel shaft.

Every linear bearing, pillow block or carriage assembly has a dynamic load rating associated with it based on a L_{10} life of 2 million inches of travel (approximately 50 km). For most applications, knowing the load applied to a linear bearing and the life required is all that is needed in selecting the proper components for the task at hand.

For more demanding applications the hardness of the shaft used, operating temperature, direction of the load, additional shock loads, and linear speed of the bearing are all factors that should be considered. This allows for an accurate prediction of the dynamic life of a linear bearing, pillow block or carriage assembly in a specific application.

Load Ratings

The applied load that a linear bearing, pillow block or carriage assembly will see needs to be compared against the load capacity of that component. The dynamic load rating of a linear bearing, pillow block or carriage assembly pertains to the component in motion and this load rating is based on the number of inches (or km) traveled.

Required Life

It is important to evaluate the required or expected life from a linear bearing system for a given application load. This required life is specified by the user as the desired life prior to a possible failure. This period of time (usually in years) then will need to be converted into a travel distance (typically inches or km) to select the appropriate size linear bearing, pillow block or carriage assembly.

Required Life Examples

Below are two examples which illustrate the importance of a dynamic load rating based upon travel life. These two applications could lead to the selection of different components due to the difference in the number of required inches of travel, even though the the applied load is the same 150 lbs (68 kg).

Example 1:

assembly needs to last 6 years
with
a 10 inch move out, then back 10 inches every 90 seconds
for
8 hours per day
for
5 days per week
and
50 weeks per year

$$\frac{(10 \times 2) \text{ inches}}{90 \text{ sec}} \times \frac{60 \text{ sec}}{1 \text{ min}} \times \frac{60 \text{ min}}{1 \text{ hr}} \times \frac{8 \text{ hr}}{1 \text{ day}} \times \frac{5 \text{ days}}{1 \text{ week}} \times \frac{50 \text{ weeks}}{1 \text{ yr}} \times 6 \text{ years} = \mathbf{9,590,400} \text{ inches of travel}$$

Example 2:

assembly needs to last 8 years
with
(24) 1 inch moves out, then back 24 inches every 30 seconds
for
12 hours per day
for
7 days per week
and
52 weeks per year

$$\frac{(24 \times 2) \text{ inches}}{30 \text{ sec}} \times \frac{60 \text{ sec}}{1 \text{ min}} \times \frac{60 \text{ min}}{1 \text{ hr}} \times \frac{12 \text{ hr}}{1 \text{ day}} \times \frac{7 \text{ days}}{1 \text{ week}} \times \frac{52 \text{ weeks}}{1 \text{ yr}} \times 8 \text{ years} = \mathbf{201,277,440} \text{ inches of travel}$$

Safety Factors

As a practice, safety factors should always be used when selecting a linear bearing, pillow block or carriage assembly for a given application. For most real world applications people do use safety factors. However, sometimes the incorrect safety factor or no safety has been used. This can lead into an unexpected system failure. **LINTECH** provides, in a chart form, different safety factor recommendations for linear bearings, pillow blocks or carriage assemblies. Keep in mind that these recommendations for safety factors are not hard and fast rules. Safety factors for a specific linear bearing system may have to be increased or decreased based upon the application requirements.

Linear Bearing Load Capacities

Linear Bearing Load Capacities are usually specified with a dynamic value. These values are used to help select the proper linear bearing, pillow block or carriage assembly size for a given load/life application. The use of adequate safety factors is a key element in the selection process of a linear bearing system for a given application. Selecting a bearing system with no safety margin can lead to problems relating to performance and long term life.

Dynamic Load Capacity

Dynamic Loads exert a force upon the linear bearing, pillow block or carriage assembly while in motion. Every linear bearing system has a load capacity associated with it that is based upon the number of inches (or km) traveled. If the load applied to the linear bearing system is less than the rated value at 2 million inches (or 50 km) of travel, the linear bearings will have a longer life associated with them that is exponential. Therefore, to properly select a linear bearing, pillow block or carriage assembly that will last the required travel life for an application, the forces acting upon the linear bearings need to be reviewed. Once the force on the heaviest loaded bearing has been determined and a proper safety factor selected, then the life of that bearing, pillow block or carriage assembly can be determined by using a simple mathematical equation.

Even though the forces acting upon a bearing, pillow block or carriage assembly can be calculated, other parameters such as changing loads, speeds, acceleration rates, environments, and lack of lubrication produce extra forces (stresses) that are hard to quantify. As a bearing moves, there are additional resultant loads as a by-product. The rate at which the bearing begins to move a load can have a large impact on its life. The linear bearings see this start/stop rate as a shock load each time. These and other variable loads cannot be calculated precisely. Thus, a safety factor should be applied to account for these loads which could fatigue the system and cause premature failure. See the below chart as a guideline.

Recommended Linear Bearing Dynamic Safety Factors

Impacts or Vibration	Speed (in/sec)	Acceleration (G's)	Min. Safety Factor - S
None	< 5	< 0.25	1.0 - 2.0
Small	5 - 10	0.25 - 0.50	2.0 - 3.0
Medium	10 - 20	0.50 - 1.00	3.0 - 4.0
Large	20 - 50	1.00 - 1.50	4.0 - 6.0
Very Large	> 50	> 1.50	6.0 - 8.0

Safety Factor Example

The application calls for moving a part (weight = 150 lbs) that is mounted to a carriage assembly. The carriage assembly will be moved to various positions at a speed of 9 IPS, with an acceleration of 0.75 G's.

From above chart - use a 3.5 safety factor

Load	Safety Factor	Select a carriage assembly that has a dynamic capacity greater than this value
150	x 3.5	= 525 lbs

Hardness factor - F_H

The maximum travel life of a linear bearing is achieved when the shaft surface has a hardness value greater than (>) Rockwell 60C. This hardness assures that no shaft grooving or flaking will occur under normal operating conditions.

<i>LINTECH</i> SL, SS, SN, SM, SA & TRSA	Rockwell Hardness	F_H factor
standard 1060 steel shafts	60-65C	1.00
440C stainless steel shafts	50-55C	.52
chrome plated 1060 steel shafts	67-72C	1.00

When using *LINTECH* bearings, pillow blocks or TRCA carriage assemblies with different shafting and hardness ratings, refer to the Shaft Hardness graph below for the correction factor.

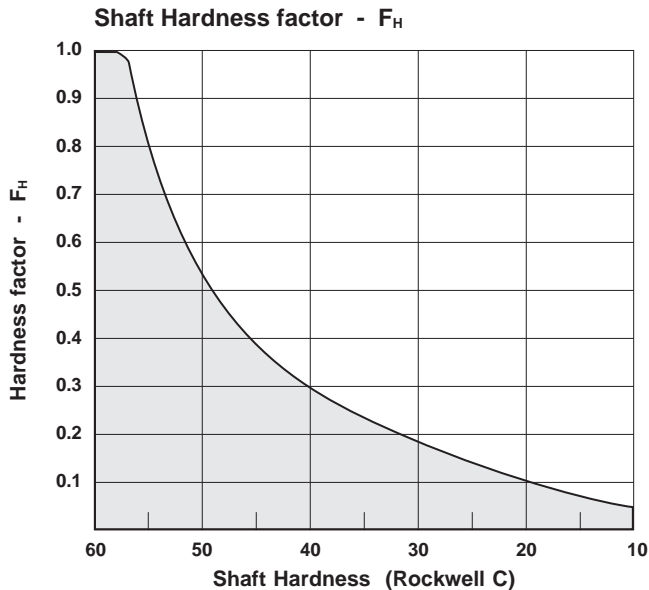

Temperature factor - F_T

Ambient temperatures over 212° F (100° C) will fatigue any linear bearing system, and will cause a decrease in travel life. Please note that some *LINTECH* linear bearings, pillow blocks and carriage assemblies have a maximum operating ambient temperature of 185° F. Therefore these bearings, pillow blocks or carriage assemblies, should never be used in ambient temperatures above 185° F.

Refer to the temperature graph below for the correction factor when using a linear bearing system in an ambient temperature that exceeds 212° F (100° C).

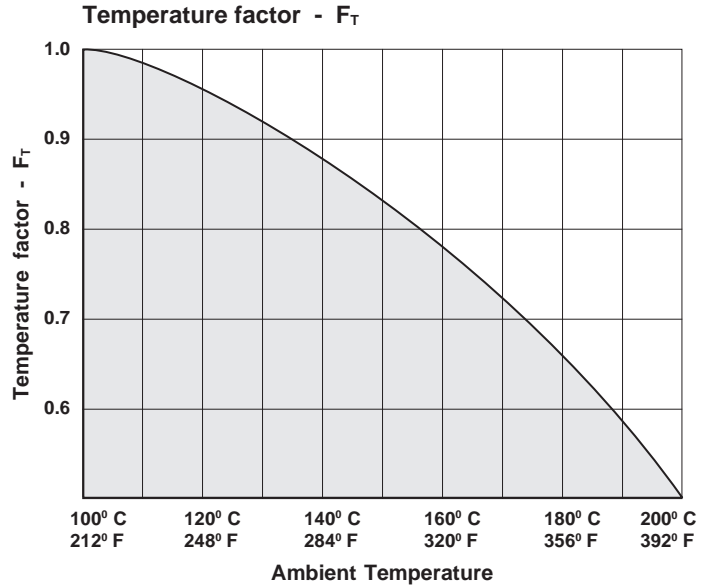

Load direction factor - F_L

The maximum travel life of a linear bearing, pillow block or carriage assembly may need to be de-rated depending upon the direction the load is applied to the bearing. The Polar charts shown below for each bearing type indicate the de-rating factor (or multiplier) based upon the direction the load is applied to the bearing. In most applications not all the bearings will see the same applied load, so you can use the adjacent equation to determine the estimated life based upon the heaviest loaded bearing or the bearing which requires the greatest de-rating factor. This will yield a system life value showing the bearing which has the lowest overall travel life. To use the below graphs, simply find the intersecting point based upon the direction of the load (that the bearing sees) and then use the de-rating factor (i.e. 0.9, etc.), if any.

$$L = \left[F_H \times F_T \times F_L \times \frac{R}{F \times S} \right]^3 \times B$$

- L = normal travel life millions of inches (or Km)
- R = rated dynamic load capacity of linear bearing, or carriage at 2 million inches of travel (or 50 Km)
- F = user applied load
- B = either 2 millions of inches (or 50 Km)
- F_H = shaft hardness factor
- F_T = environment temperature factor
- F_L = load direction factor
- S = dynamic safety factor

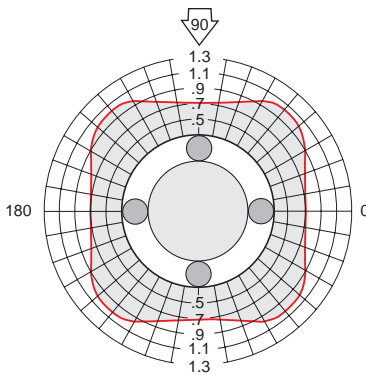

LBC-4
LBC-6, LBCA-6
LBC-8, LBCA-8, SLBC-8, DLBC-8
LBCA-10

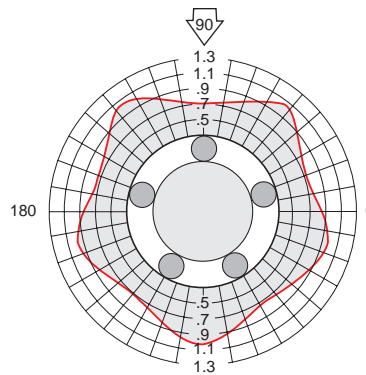

LBC-10, SLBC-10, DLBC-10
LBCA-12, LBCA-16
LBCM-16, LBCME-16

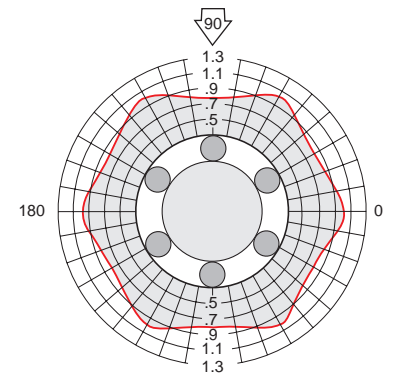

LBC-12, SLBC-12, DLBC-12
LBC-16, SLBC-16, DLBC-16
LBC-20, LBCA-20, SLBC-20, DLBC-20
LBC-24, LBCA-24, SLBC-24, DLBC-24
LBC-32, LBCA-32, SLBC-32
LBCM-20, LBCM-25, LBCM-30, LBCM-40
LBCME-20, LBCME-25, LBCME-30
LBCME-40, LBCME-50

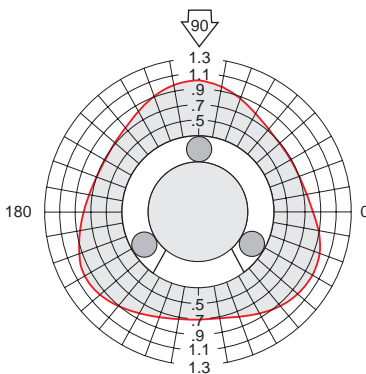

LBCA-4
LBOA-8
LBOA-10

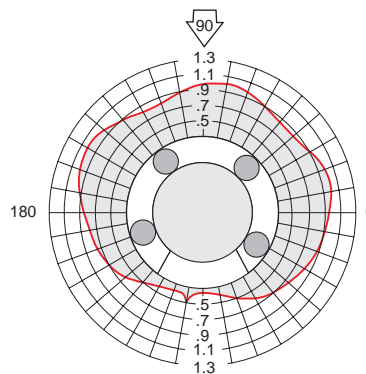

LBO-8, SLBO-8, DLBO-8
LBO-10, SLBO-10, DLBO-10
LBOA-12, LBOA-16
LBOM-16, LBOME-16

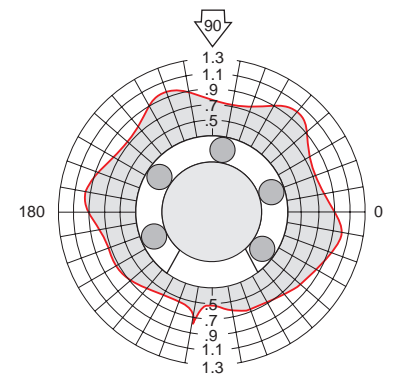

LBO-12, SLBO-12, DLBO-12
LBO-16, SLBO-16, DLBO-16
LBO-20, LBOA-20, SLBO-20, DLBO-20
LBO-24, LBOA-24, SLBO-24, DLBO-24
LBO-32, LBOA-32, SLBO-32
LBOM-20, LBOM-25, LBOM-30, LBOM-40
LBOME-20, LBOME-25, LBOM-30
LBOME-40, LBOME-50

Lubrication

LINTECH shafts, shaft assemblies, linear bearings, pillow blocks or carriage assemblies require a small amount of grease or oil for proper, long term operation. Lubrication will decrease system wear and the potential for rusting of shafts and linear bearing surfaces. For most applications a medium to heavy oil, light grease, or silicone based lubricant is recommended. The many built-in pockets within the linear bearing allows the adhesive properties of these lubricants to be stored for extended periods of time while minimizing sealing problems.

To obtain the estimated travel life for a given application, the linear bearings, pillow blocks or carriage assemblies should not run dry for an extended period of time. This lubrication schedule will ultimately need to be determined empirically during operation at the installation site since it can vary depending upon the environment, operation conditions, quantity and type of lube used, and other unforeseen conditions.

All **LINTECH** shafts, shaft assemblies, linear bearings, pillow blocks and carriage assemblies are shipped lightly coated with a rust preventative oil in the bearings or on the shafts. This will help prevent corrosion during the shipping period of the product. It is highly recommended that all shafts, shaft assemblies, linear bearings, pillow blocks and carriage assemblies be lubricated during installation or prior to operation. Also, periodic re-lubrication of the linear bearings and shafts, will help assure that the rated life of the system is obtained.

NOTE: Use of WD-40 or other cleaning solvents should strictly be avoided as they can cause damage to the linear bearing and shaft.

Frictional Resistance

The total friction resistance of a **LINTECH** linear bearing, pillow block or carriage assembly can be calculated by using the following equation.

$$R = [W \times \mu] + F_s$$

R = Frictional resistance (lbs)

W = Load weight (lbs)

μ = coefficient of friction

F_s = Frictional resistance - seal drag (lbs)

Note: **LINTECH** recommends using **μ** = .01 for all linear bearing systems.

The coefficient of friction (**μ**) of a **LINTECH** linear bearing, pillow block or carriage assembly consists of the rolling friction and the static (breakaway) friction. Two main factors affect the coefficient value. The type of lubrication used (i.e. oil, grease, or none) and the ratio between the total load weight and the dynamic load rating of the linear bearing, pillow block or carriage assembly used.

For most applications, **LINTECH** recommends using a value of .01 for the coefficient of friction. This value can be used for all linear bearings systems. The .01 value provides for an adequate safety margin when evaluating system performance. Other frictional resistances of a **LINTECH** linear bearing are seal drag and system preload. While wiper seals are used to retain lubricants and prevent entry of foreign particles into the linear bearing, they will increase the frictional resistance of the system. Increasing the preload of a linear bearing will also add extra frictional resistance. The chart below lists the nominal values for frictional seal drag of **LINTECH** linear bearings, pillow blocks and carriage assemblies.

Frictional Resistance - F_s (seal drag)

Bearing size -S (Sealed Versions) and Pillow Blocks	F _s (lbs)	Carriage Model TRCA series	F _s (lbs)
Single, 0.50" diameter	0.5	TRCA-8-xx	2.0
Single, 0.62" diameter	0.4	TRCA-10-xx	1.6
Single, 0.75" diameter	0.4	TRCA-12-xx	1.6
Single, 1.00" diameter	0.4	- TRCA-16-xx	1.6
Single, 1.25" diameter	5.0	TRCA-20-xx	20.0
Single, 1.50" diameter	7.0	TRCA-24-xx	28.0
Single, 2.00" diameter	8.0	TRCA-32-xx	32.0
Double, 0.50" diameter	0.5	TRCA-8-6	1.0
Double, 0.62" diameter	0.4	TRCA-10-6	0.8
Double, 0.75" diameter	0.4	TRCA-12-6	0.8
Double, 1.00" diameter	0.4	TRCA-16-6	0.8
Double, 1.25" diameter	5.0	TRCA-20-8	10.0
Double, 1.50" diameter	7.0	TRCA-24-12	14.0

All individual bearing force equations below pertain to a four bearing carriage which is at constant uniform velocity or with the carriage at rest. During acceleration and deceleration intervals of a positioning system, the force exerted upon an individual bearing changes as the acceleration or deceleration rate varies. In most cases, the extra force acting upon an individual bearing during the acceleration interval is offset by a reduced force during the deceleration interval. Therefore, using just the constant uniform velocity equations will adequately determine the life of an individual bearing for a particular application.

- d_1 - distance between center lines of shafts or rails (in)
- d_2 - distance between center lines of linear bearing blocks (in)
- d_3 - distance between carriage center and load center of gravity (in)
- d_4 - distance between carriage center and load center of gravity (in)
- d_r - distance between carriage surface and linear bearings (in)
- F_{BX} - force acting upon bearing in X-axis direction (lbs)
- F_{BY} - force acting upon bearing in Y-axis direction (lbs)
- F_{BZ} - force acting upon bearing in Z-axis direction (lbs)
- W - load weight (lbs)

Horizontal Applications

Example #1

Example #2

$$F_{1z} = \frac{W}{4} + \left[\frac{W}{2} \times \frac{d_4}{d_2} \right] + \left[\frac{W}{2} \times \frac{d_3}{d_1} \right]$$

$$F_{2z} = \frac{W}{4} - \left[\frac{W}{2} \times \frac{d_4}{d_2} \right] + \left[\frac{W}{2} \times \frac{d_3}{d_1} \right]$$

$$F_{3z} = \frac{W}{4} + \left[\frac{W}{2} \times \frac{d_4}{d_2} \right] - \left[\frac{W}{2} \times \frac{d_3}{d_1} \right]$$

$$F_{4z} = \frac{W}{4} - \left[\frac{W}{2} \times \frac{d_4}{d_2} \right] - \left[\frac{W}{2} \times \frac{d_3}{d_1} \right]$$

Side Mounted Applications

$$F_{1z} = F_{3z} = \frac{W}{4} + \left[\frac{W}{2} \times \frac{d_4}{d_2} \right]$$

$$F_{2z} = F_{4z} = \frac{W}{4} - \left[\frac{W}{2} \times \frac{d_4}{d_2} \right]$$

$$F_{1y} \sim F_{3y} = \left[\frac{W}{2} \times \frac{d_3 + d_r}{d_1} \right]$$

Vertical Applications

$$F_{1x} \sim F_{3x} = \frac{W}{2} \times \frac{d_4 + d_r}{d_2}$$

$$F_{1y} \sim F_{3y} = \frac{W}{2} \times \frac{d_3}{d_2}$$

$$F_{1x} + F_{3x} \sim F_{2x} + F_{4x}$$

$$F_{1y} + F_{3y} \sim F_{2y} + F_{4y}$$

Mean Bearing Load Calculation

When the force acting upon an individual bearing varies, as is the case with the bottom axis bearings of a multi-axes positioning system, a mean bearing load calculation determines the life of that bearing.

$$F_{avg} = \frac{1}{3} (F_{min} + 2 \times F_{max})$$

- F_{avg} - average force acting upon bearing (lbs)
- F_{min} - minimum force acting upon bearing (lbs)
- F_{max} - maximum force acting upon bearing (lbs)

TRCA Rated Load Capacity

The **LINTECH** TRCA series, **TWIN RAIL**® carriage assembly consists of (2) DLBO or (4) SLBO series pillow blocks mounted to a precision machined aluminum plate. The pillow blocks are mounted, aligned, and then doweled in-place. They are designed to mate directly with the **LINTECH** TRSA series, **TWIN RAIL**® shaft assemblies. Using these two series in combination with each other will eliminate the requirement to align and set-up a mechanical positioning system to be parallel.

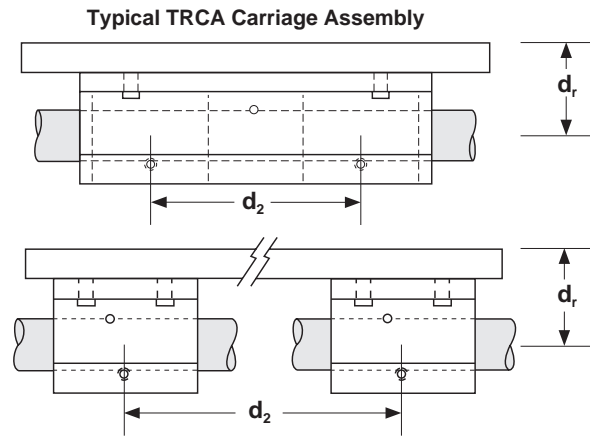

TRCA Carriage Assemblies

Model Number	Nominal Shaft Dia. (inches)	Carriage Length (inches)	Linear Bearing Used	Each Bearing (1) Dyn. Load Capacity (lbs)	Dyn. Load Capacity (lbs)	d _r (inches)	d ₁ (inches)	d ₂ (inches)
TRCA8-6	0.500	6.00	DLBO-8	230	920	1.062	3.00	1.90
TRCA8-12	0.500	12.00	SLBO-8	230	920	1.062	3.00	10.00
TRCA8-18	0.500	18.00	SLBO-8	230	920	1.062	3.00	16.00
TRCA10-6	0.625	6.00	DLBO-10	320	1,280	1.250	3.75	2.15
TRCA10-12	0.625	12.00	SLBO-10	320	1,280	1.250	3.75	9.75
TRCA10-18	0.625	18.00	SLBO-10	320	1,280	1.250	3.75	15.75
TRCA12-6	0.750	6.00	DLBO-12	470	1,880	1.437	4.50	2.50
TRCA12-12	0.750	12.00	SLBO-12	470	1,880	1.437	4.50	9.62
TRCA12-18	0.750	18.00	SLBO-12	470	1,880	1.437	4.50	15.62
TRCA16-6	1.000	6.00	DLBO-16	780	3,120	1.687	5.25	3.25
TRCA16-12	1.000	12.00	SLBO-16	780	3,120	1.687	5.25	8.87
TRCA16-18	1.000	18.00	SLBO-16	780	3,120	1.687	5.25	14.87
TRCA16-24	1.000	24.00	SLBO-16	780	3,120	1.687	5.25	20.87
TRCA20-8	1.250	8.00	DLBO-20	1,170	4,680	2.250	6.00	3.90
TRCA20-12	1.250	12.00	SLBO-20	1,170	4,680	2.250	6.00	8.12
TRCA20-18	1.250	18.00	SLBO-20	1,170	4,680	2.250	6.00	14.12
TRCA20-24	1.250	24.00	SLBO-20	1,170	4,680	2.250	6.00	20.12
TRCA24-12	1.500	12.00	DLBO-24	1,560	6,240	2.750	6.62	5.00
TRCA24-18	1.500	18.00	SLBO-24	1,560	6,240	2.750	6.62	13.75
TRCA24-24	1.500	24.00	SLBO-24	1,560	6,240	2.750	6.62	19.75
TRCA24-30	1.500	30.00	SLBO-24	1,560	6,240	2.750	6.62	25.75
TRCA32-18	2.000	18.00	SLBO-32	2,350	9,400	3.375	7.25	12.75
TRCA32-24	2.000	24.00	SLBO-32	2,350	9,400	3.375	7.25	18.75
TRCA32-30	2.000	30.00	SLBO-32	2,350	9,400	3.375	7.25	24.75

Footnotes:

(1) Rating based upon 2 million inches of travel with the load forces being applied downward on the linear bearing, while in a horizontal application, and based upon 1060 steel shafting (Rockwell 60C). The actual load rating, and life, is dependent upon factors detailed on pages 6 to 11.

TRCA Rated Load Capacity

The dynamic load capacity of a **LINTECH** TRCA carriage assembly is based upon having the load forces centered on the carriage and the combined dynamic load capacity values of the SLBO or DLBO linear bearings used. The rated values are based on a L_{10} life of 2 million inches of travel (or 50 km) and with the load forces applied downward onto the carriage assembly.

For a given carriage assembly, as the load force decreases, the life of the carriage assembly will increase exponentially. The life of a carriage assembly, used in an application, can be determined by reviewing the load considerations found on pages 6 to 11.

TRCA Rated Moment Loads

When using a **LINTECH** TRCA carriage assembly in an application, a moment load exists when the load center of gravity is located away from the center of the carriage assembly. The life of a carriage assembly is determined by the heaviest loaded linear bearing. Follow the steps below to determine if a specific TRCA carriage assembly will operate sufficiently in a given application.

Step 1: Calculate the forces acting on each of the individual bearings for a given configuration and TRCA carriage assembly by using the equations on page 11.

Step 2: Compare the calculated values with the rated dynamic load capacity values for the SLBO or DLBO linear bearings used on the TRCA carriage assembly. Make sure the calculated values are below the rated values. **Note:** If the calculated forces are acting on the open end of a linear bearing, reduce the rated dynamic load capacity of that bearing by the value shown on the Polar Charts found on page 9.

Step 3: Follow the information on pages 6 through 11 to determine the theoretical travel life of the selected carriage assembly in inches (or km) of travel.

Load Centered on Carriage

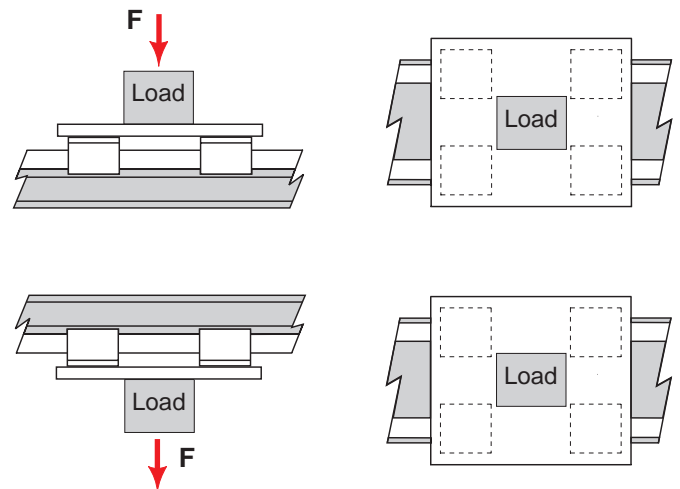

Load Center away from Carriage Center

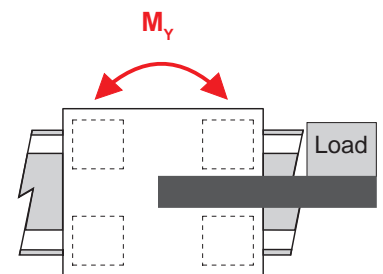
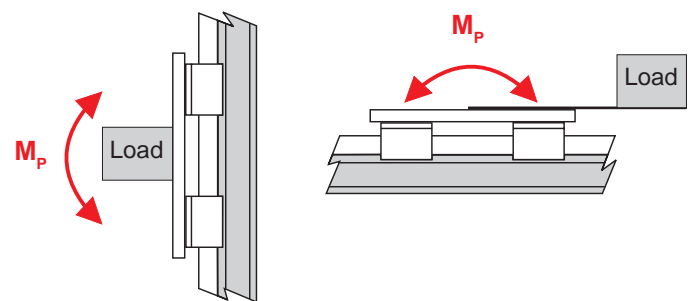
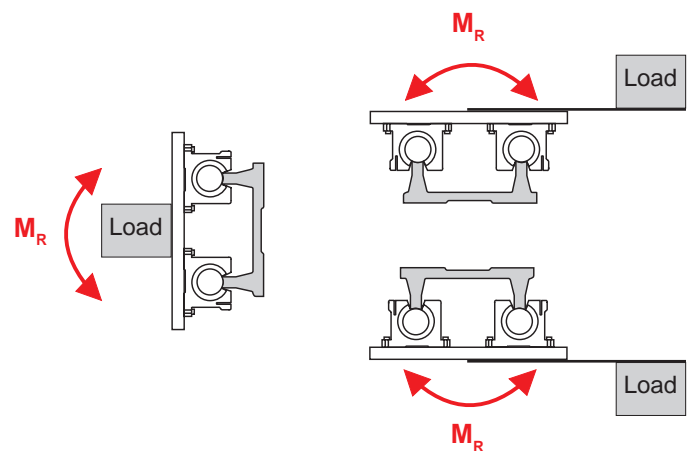

Shaft Deflection

The equations below can be used when *LINTECH* closed linear bearings (LBC, LBCA, SLBC or DLBC series), and precision hardened shafting is used with shaft end supports (ES series), or with threaded shaft ends attached to a plate on each end. The estimated deflection that a configuration will experience is dependent upon the shaft diameter, unsupported shaft length, shaft material, along with the type and number of bearings being used.

Minimizing the deflection of the components will reduce additional stresses which can lead to premature failure. Excessive deflection can cause binding or rough operation when the bearings are at the area of travel furthest from the supported portion, which is usually at mid-stroke.

- D** = deflection (inches) (mm)
- W** = user applied load (lbs) (N)
- L** = length of unsupported shaft (inches) (mm)
- C** = distance from support to center of first bearing (inches) (mm)
- T** = shaft weight per length (lbs/in) (N/mm)
- S_k** = strength constant - modulus of elasticity x moment of inertia

Model Number	Nominal Shaft Diameter (inches)	Shaft Weight T (lbs/in)	Strength Factor S _k (lb/in ²)
Sx4	0.250	0.014	5,700
Sx6	0.375	0.031	29,100
Sx8	0.500	0.055	91,800
Sx10	0.625	0.086	224,400
Sx12	0.750	0.125	465,000
Sx16	1.000	0.222	1,470,000
Sx20	1.250	0.348	3,594,000
Sx24	1.500	0.500	7,455,000
Sx32	2.000	0.890	23,562,000

Model Number	Nominal Shaft Diameter (mm)	Shaft Weight T (N/mm)	Strength Factor S _k (N/mm ²)
SM8	8	0.0038	38.26
SM10	10	0.0061	93.41
SM12	12	0.0087	193.70
SM16	16	0.0154	612.20
SM20	20	0.0240	1,495.00
SM25	25	0.0379	3,649.00
SM30	30	0.0542	7,566.00
SM40	40	0.0968	23,910.00
SM50	50	0.1513	58,380.00

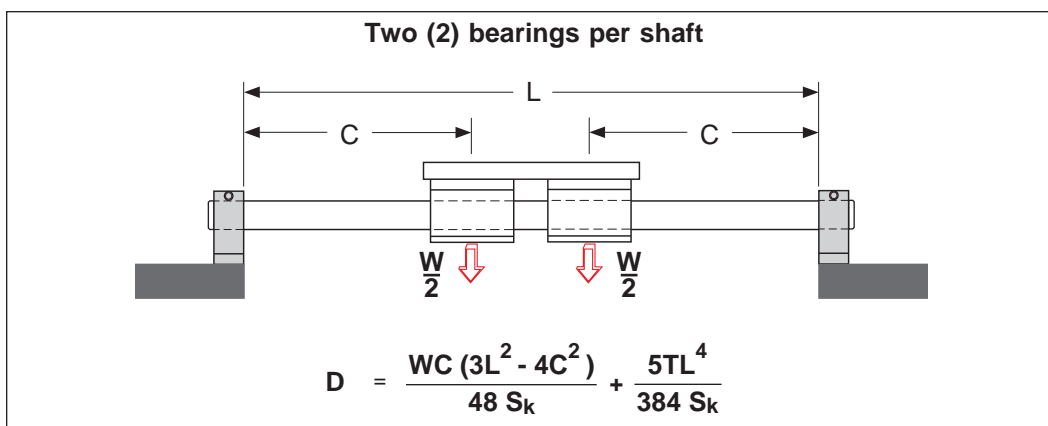
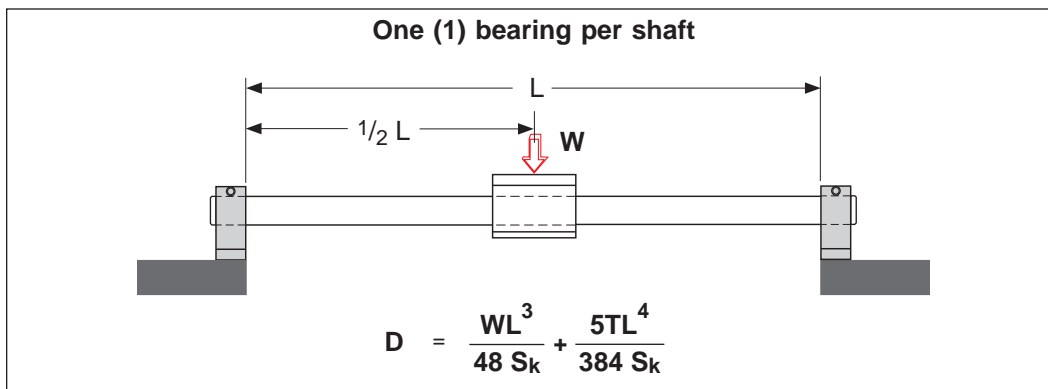

Life Example

The following example is provided to aid in the understanding of how the various charts and equations in this technical section should be implemented. For this example, the life estimation will be determined for an application that will use a **LINTECH** TRCA carriage assembly with a TRSA shaft assembly.

Application Parameters

The load weight of 100 lbs is centered on the TRCA carriage along with a 12 inch total travel in the horizontal plane. The **LINTECH** TRSA shaft assembly will use 440C stainless steel shafts, and will be mounted to a support structure so that the carriage will be inverted. Various outward moves will be made with a maximum return speed of 5 IPS. This return speed will be the most demanding speed profile in the application and the installation environment will be at 80° F.

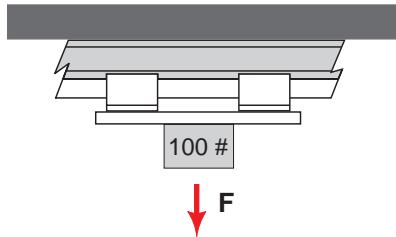

Different Options

In the application below, utilizing a custom carriage length which has six (6) SLBO-12 pillow blocks instead of two (2) DLBO-12 pillow blocks on the TRCA12 carriage assembly, would increase the R value from 1,880 to 2,820 lbs. Thus, increasing the L life estimate value to 98,538,824 inches of travel from 29,196,688 inches of travel.

Another option would be to utilize chrome plated shafts for the TRSA assembly instead of the 440C stainless steel shafts. This would increase the shaft hardness factor to 1 instead of 0.52. Thus, increasing the L life estimate value to 207,646,00 inches of travel from 29,196,688 inches of travel for just using the standard TRCA12-6.

Determine Safety and Correction Factors

- Step 1: Use chart on page 7 for 5 IPS to select a safety factor: $S = 2$
- Step 2: Use chart on page 8 for 440C to select a shaft hardness factor: $F_H = .52$
- Step 3: Use graph on page 8 for 80° F to select a temperature factor: $F_T = 1$
- Step 4: Would like to use a TRCA12-6. From chart on page 12: $R = 1,880$ lbs
- Step 5: Use polar graph on page 9 to select load direction factor: $F_L = .5$
- Step 6: Use the equation on page 9 to compute the estimated life:

$$L = \left[F_H \times F_T \times F_L \times \frac{R}{F \times S} \right]^3 \times B$$

$$L = \left[.52 \times 1 \times .5 \times \frac{1880}{100 \times 2} \right]^3 \times 2,000,000$$

$$L = 29,196,688 \text{ inches of travel}$$

- Step 7: Use the equation on page 6 to determine the required life of your application. If the estimated L value above (for a 100 pound load) is less than your desired life, then select a larger carriage assembly from the chart on page 12, and then plug its dynamic load capacity for the R value into the equation above to re-calculate the estimated L life. As an example, the TRCA16-6 load rating of 3,120 lbs would increase the L life estimate to 133,451,615 inches of travel from 29,196,688 inches of travel.

Shafting & Shaft Assembly Applications

LINTECH shafts, shaft assemblies, linear bearings, pillow blocks and carriage assemblies are used in many different applications requiring mechanical motion. These components are utilized with air cylinders, hydraulic actuators, lead screws, rack & pinion systems, belt & pulleys, chain & sprockets, as well as in manual positioning systems. **LINTECH** individual shafts or SA shaft assemblies, along with individual linear bearings or pillow blocks, are typically used when a designer wishes to spread apart the shafts or SA shaft assemblies and make a custom carriage assembly. The TRSA shaft assemblies and TRCA carriage assemblies are utilized together when ease of installation is of essence.

