

9 06 06 - WC0 - 1 - S005 - M02 - C155 - L01 - E00 - B00

Table Series

Carriage Length

06 - 6 inches **12** - 12 inches

Travel Length (see pages D-6 & D-8)

06 - 6 to 60 inches

Waycovers

WC0 - with no waycovers **WC1** - with waycovers

Carriage Inserts (see pages D-7 & D-9)

1 - English mount **2** - Metric mount

Screw Options (see pages D-18 to D-25)

<i>Rolled ball screws</i>	<i>Rolled ball screws</i>	<i>Precision ball screws</i>
S005 - .625 x .200 NPL	S021 - 1.000 x .250 NPL	S114 - .625 x .200 NPL
S006 - .625 x .200 PL	S022 - 1.000 x .250 PL	S115 - .625 x .200 PL
S007 - .625 x .200 NPL(T)	S023 - 1.000 x .250 NPL(T)	S116 - 16 x 5 NPL
S008 - .625 x .200 PL(T)	S024 - 1.000 x .250 PL(T)	S117 - 16 x 5 PL
S009 - .625 x 1.000 NPL	S025 - 1.000 x .500 NPL	S118 - 16 x 10 NPL
S010 - .625 x 1.000 PL	S026 - 1.000 x .500 PL	S119 - 16 x 10 PL
S011 - .625 x 1.000 NPL(T)	S027 - 1.000 x .500 NPL(T)	S120 - 16 x 16 NPL
S012 - .625 x 1.000 PL(T)	S028 - 1.000 x .500 PL(T)	S121 - 16 x 16 PL
S013 - .750 x .200 NPL	S029 - 1.000 x 1.000 NPL	S122 - .750 x .200 NPL
S014 - .750 x .200 PL	S030 - 1.000 x 1.000 PL	S123 - .750 x .200 PL
S015 - .750 x .200 NPL(T)	S031 - 1.000 x 1.000 NPL(T)	S124 - 20 x 5 NPL
S016 - .750 x .200 PL(T)	S032 - 1.000 x 1.000 PL(T)	S125 - 20 x 5 PL
S017 - .750 x .500 NPL		S128 - 20 x 20 NPL
S018 - .750 x .500 PL	<i>Ground ball screws</i>	S129 - 20 x 20 PL
S019 - .750 x .500 NPL(T)	S212 - .625 x .200 PL	
S020 - .750 x .500 PL(T)	S213 - .625 x .500 PL	<i>Rolled acme screws</i>
	S214 - 16 x 5 PL	S300 - .625 x .100 NPL
	S215 - 16 x 16 PL	S301 - .625 x .100 PL
S999 - other		S302 - .625 x .200 NPL
		S303 - .625 x .200 PL

Motor Mount (see pages D-7 & D-9, D-28 to D-29)

M00 - none	M02 - NEMA 23 mount (E)	M07 - NEMA 23 (LH) wrap
M01 - hand crank	M03 - NEMA 23 mount (M)	M08 - NEMA 34 (RH) wrap
	M04 - NEMA 34 mount (E)	M09 - NEMA 34 (LH) wrap
M99 - other	M05 - NEMA 34 mount (M)	M12 - NEMA 42 (RH) wrap
	M06 - NEMA 23 (RH) wrap	M13 - NEMA 42 (LH) wrap

Coupling Options (see pages D-26 to D-27)

C000 - none	C025 to C029 - C100	C130 to C134 - H100	C407 to C413 - G100
C999 - other	C048 to C055 - C125	C155 to C164 - H131	C435 to C444 - G126

Limit & Home Switches (see pages D-15 to D-17)

L00 - no switches		Mechanical	Reed	Hall	Prox (NPN)	Prox (PNP)
L99 - other	EOT & home switches	L01	L04	L07	L10	L13
	EOT switches only	L02	L05	L08	L11	L14
	home switch only	L03	L06	L09	L12	L15

Encoder Options (see page D-31)

E00 - none	E02 - rotary (1000 lines/rev)	E10 - linear (2500 lines/inch)	E99 - other
E01 - rotary (500 lines/rev)	E03 - rotary (1270 lines/rev)	E11 - linear (125 lines/mm)	

Power-off Brakes (see page D-30)

B00 - none	B01 - 24 VDC	B02 - 90 VDC	B99 - other
-------------------	---------------------	---------------------	--------------------

(E) - English Interface (NPL) - Non Preloaded
 (LH) - Left Hand (PL) - Preloaded
 (M) - Metric Interface (RH) - Right Hand
 (T) - Turcite Nut

Specifications subject to change without notice

Specifications

Load Capacities		6 inch (4 bearing) Carriage		12 inch (4 bearing) Carriage	
Dynamic Horizontal ⁽¹⁾	2 million inches (50 km) of travel	3,300 lbs	(1496 kg)	3,300 lbs	(1496 kg)
Dynamic Horizontal ⁽¹⁾	50 million inches (1270 km) of travel	1,125 lbs	(510 kg)	1,125 lbs	(510 kg)
Static Horizontal ⁽¹⁾		5,000 lbs	(2268 kg)	5,000 lbs	(2268 kg)
Dynamic Roll Moment ⁽¹⁾	2 million inches (50 km) of travel	380 ft-lbs	(515 N-m)	380 ft-lbs	(515 N-m)
Dynamic Roll Moment ⁽¹⁾	50 million inches (1270 km) of travel	130 ft-lbs	(176 N-m)	130 ft-lbs	(176 N-m)
Static Roll Moment ⁽¹⁾		575 ft-lbs	(780 N-m)	575 ft-lbs	(780 N-m)
Dyn. Pitch & Yaw Moment ⁽¹⁾	2 million inches (50 km) of travel	150 ft-lbs	(203 N-m)	525 ft-lbs	(712 N-m)
Dyn. Pitch & Yaw Moment ⁽¹⁾	50 million inches (1270 km) of travel	51 ft-lbs	(69 N-m)	179 ft-lbs	(243 N-m)
Static Pitch & Yaw Moment ⁽¹⁾		225 ft-lbs	(305 N-m)	790 ft-lbs	(1071 N-m)
Each Bearing Dyn. Cap. ⁽¹⁾	2 million inches (50 km) of travel	825 lbs	(374 kg)	825 lbs	(374 kg)
Each Bearing Dyn. Cap. ⁽¹⁾	50 million inches (1270 km) of travel	282 lbs	(128 kg)	282 lbs	(128 kg)
Each Bearing Static Load Capacity ⁽¹⁾		1,250 lbs	(567 kg)	1,250 lbs	(567 kg)
Thrust Force Capacity	10 million screw revolutions	895 lbs	(406 kg)	895 lbs	(406 kg)
Thrust Force Capacity	500 million screw revolutions	240 lbs	(109 kg)	240 lbs	(109 kg)
Maximum Acceleration		772 in/sec ²	(19,6 m/sec ²)	772 in/sec ²	(19,6 m/sec ²)
d₁	Center to center distance (spread) between the two rails	4.500 in	(114,3 mm)	4.500 in	(114,3 mm)
d₂	Center to center distance (spacing) of the bearings on a single rail	2.500 in	(63,5 mm)	8.620 in	(218,9 mm)
d_r	Center distance of the bearing to top of carriage plate surface	1.437 in	(36,5 mm)	1.437 in	(36,5 mm)

Other	For Six (6) & Twelve (12) inch Carriages
Table Material	Base, Carriage, End Plates, & Cover Plate option - 6061 anodized aluminum
Linear Rail Material	Case Hardened Steel
Screw Material (see pages D-18 to D-25)	Acme Screw - Stainless Steel
Screw Material (see pages D-18 to D-25)	Rolled Ball, Precision Ball, & Ground Ball - Case Hardened Steel
Straightness	< 0.00016 in/in (< 4,06 microns/25mm)
Flatness	< 0.00016 in/in (< 4,06 microns/25mm)
Orthogonality (multi-axis systems)	< 30 arc-seconds
Friction Coefficient	< 0.01
Motor Mount	NEMA 23 & 34 Mounts, Metric Mounts, Motor Wraps, and Hand Crank Option
Coupling	Three (3) different styles available
Waycover Material	Hypilon Polyester Bellows firmly mounted to carriage & end plates

Footnotes:

(1) Derate value by 50 % when load is applied to the open end of the bearing (such as in moment loads and inverted configurations).

Dimensions & Specifications

- Without Waycovers -

Model Number	Travel Length inches (mm)	Table Dimensions inches (mm)		Mounting Dimensions inches (mm)				Screw Length inches (mm)	Table Weight ⁽¹⁾ lbs (kg)
		A	B	C	D	E	M		
90606-WC0	6 (150)	13.25 (336,5)	15.75 (400,0)	10.00 (254,0)	6.00 (152,4)	4.00 (101,6)	6	14.94 (379,4)	13.3 (6,0)
90612-WC0	12 (300)	19.25 (488,9)	21.75 (552,4)	16.00 (406,4)	See Detail 1		8	20.94 (531,9)	16.8 (7,6)
90618-WC0	18 (455)	25.25 (641,3)	27.75 (704,8)	22.00 (558,8)	See Detail 2		10	26.94 (684,3)	20.0 (9,1)
90624-WC0	24 (605)	31.25 (793,7)	33.75 (857,2)	28.00 (711,2)	See Detail 3		14	32.94 (836,7)	31.0 (14,1)
90630-WC0	30 (760)	37.25 (946,1)	39.75 (1009,6)	34.00 (863,6)	See Detail 4		16	38.94 (989,1)	36.0 (16,3)
90636-WC0	36 (910)	43.25 (1098,5)	45.75 (1162,0)	40.00 (1016,0)	See Detail 5		18	44.94 (1141,5)	41.0 (18,6)
90648-WC0	48 (1215)	55.25 (1403,3)	57.75 (1466,8)	52.00 (1320,8)	See Detail 7		24	56.94 (1446,3)	51.0 (23,1)
90660-WC0	60 (1520)	67.25 (1708,1)	69.75 (1771,6)	64.00 (1625,6)	See Detail 9		28	68.94 (1751,1)	61.0 (27,7)
91206-WC0	6 (150)	19.25 (488,9)	21.75 (552,4)	16.00 (406,4)	See Detail 1		8	20.94 (531,9)	21.3 (9,7)
91212-WC0	12 (300)	25.25 (641,3)	27.75 (704,8)	22.00 (558,8)	See Detail 2		10	26.94 (684,3)	23.5 (10,7)
91218-WC0	18 (455)	31.25 (793,7)	33.75 (857,2)	28.00 (711,2)	See Detail 3		14	32.94 (836,7)	33.0 (15,0)
91224-WC0	24 (605)	37.25 (946,1)	39.75 (1009,6)	34.00 (863,6)	See Detail 4		16	38.94 (989,1)	38.0 (17,2)
91230-WC0	30 (760)	43.25 (1098,5)	45.75 (1162,0)	40.00 (1016,0)	See Detail 5		18	44.94 (1141,5)	43.0 (19,5)
91236-WC0	36 (910)	49.25 (1250,9)	51.75 (1466,8)	46.00 (1168,4)	See Detail 6		24	50.94 (1293,9)	48.0 (21,8)
91248-WC0	48 (1215)	61.25 (1555,7)	63.75 (1619,2)	58.00 (1473,2)	See Detail 8		28	62.94 (1598,7)	58.0 (26,3)
91260-WC0	60 (1520)	73.25 (1860,5)	75.75 (1924,0)	70.00 (1778,0)	See Detail 10		30	74.94 (1903,5)	68.0 (30,8)

- 06 = Carriage length is 06 inch (152,4 mm) with 4 bearings; Carriage weight = 5.25 lbs. (2,38 kg)
- 12 = Carriage length is 12 inch (304,8 mm) with 4 bearings; Carriage weight = 8.00 lbs. (3,63 kg)

Footnotes:

(1) Weight shown is with a 0.625 inch (16 mm) diameter screw, a NEMA 23 motor mount [0.34 lbs (0,16 kg)], and a C100 style [0.09 lbs (0,04 kg)] coupling. When using a 0.750 inch (20 mm) diameter screw add 0.042 lbs per inch (0,00075 kg per mm) of screw length for a given model number. When using a 1.000 inch diameter screw add 0.117 lbs per inch (0,0021 kg per mm) of screw length for a given model number.

Dimensions

- Without Waycovers -

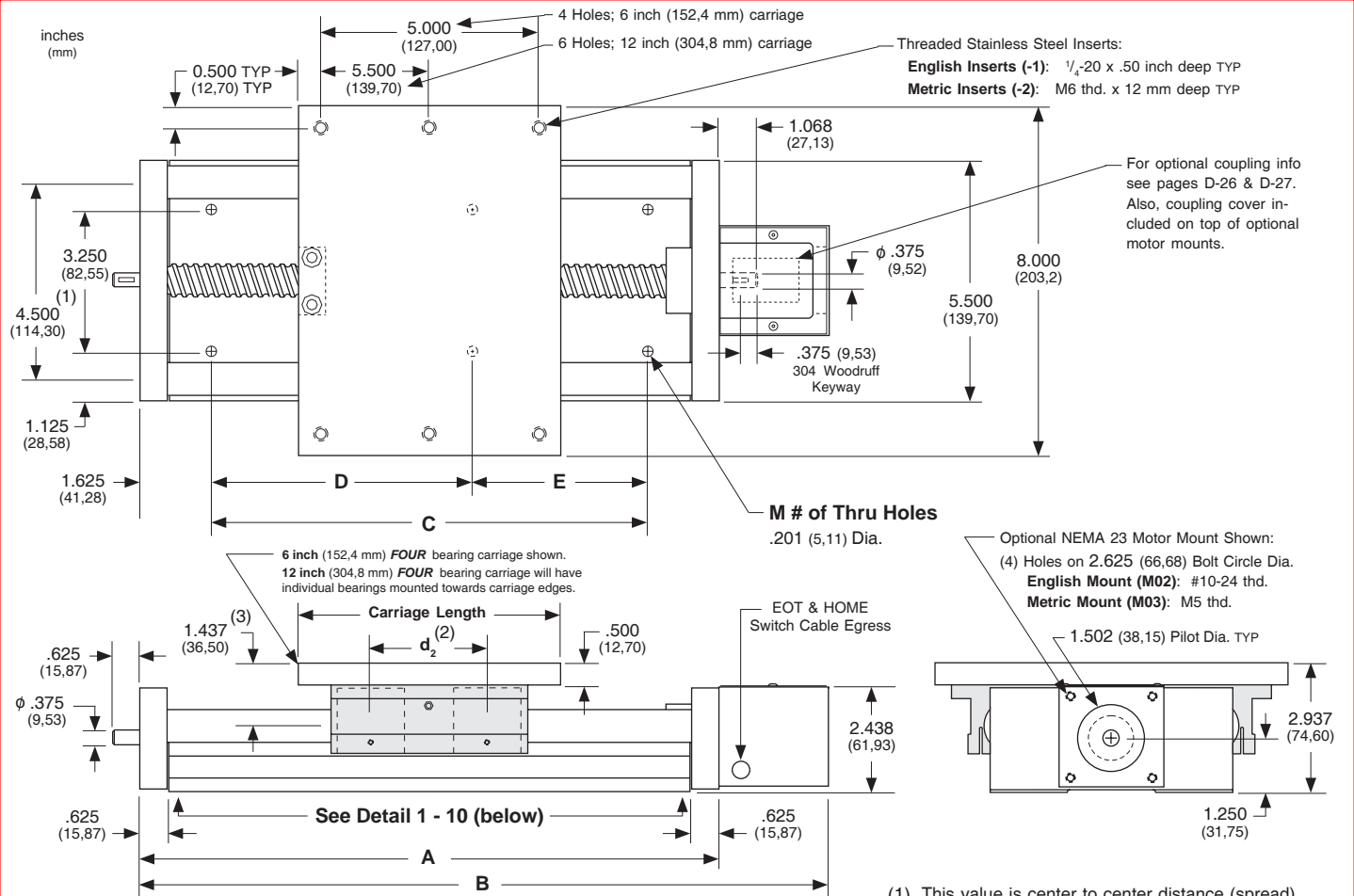

(1) This value is center to center distance (spread) between the two rails (d_1).

(2) This value is center to center distance (spacing) of the bearings on a single rail (d_2) [see page D-5].

(3) This value is center distance of the bearing to top of carriage plate surface (d_3).

Note: Any 90 series table can be mounted on top of any second 90 series, in order to create X-Y multiple axis configurations. The carriage's threaded stainless steel insert hole pattern DOES NOT exactly match the base mounting hole pattern on each table, therefore machining of the bottom axis carriage plate is required. Please contact *LINTECH*.

1 Mounting Details 1 through 10

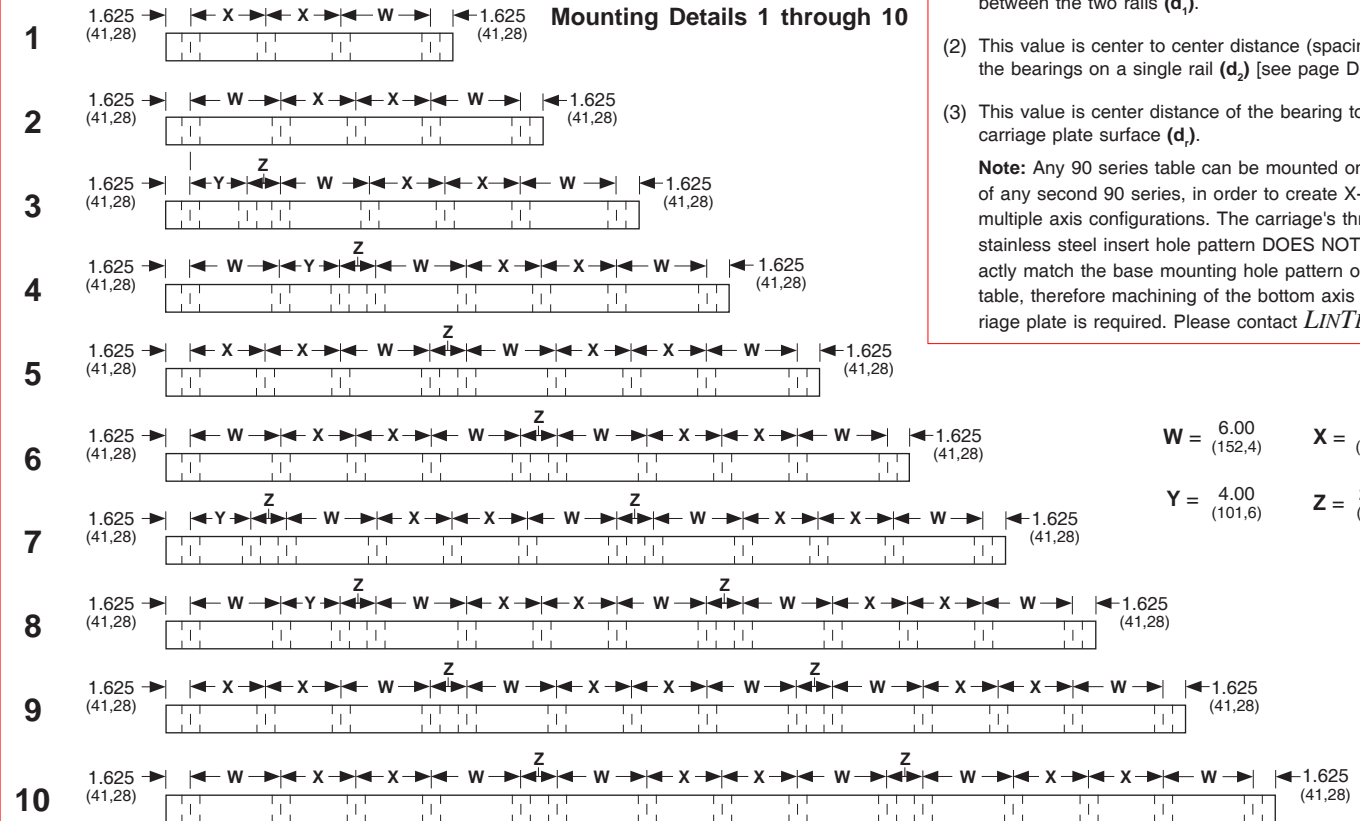

$W = 6.00$ (152,4) $X = 5.00$ (127,0)

$Y = 4.00$ (101,6) $Z = 2.00$ (50,8)

Specifications subject to change without notice

Dimensions & Specifications

- With Waycovers -

Model Number	Travel Length inches (mm)	Table Dimensions inches (mm)		Mounting Dimensions inches (mm)				Screw Length inches (mm)	Table ⁽¹⁾ Weight lbs (kg)
		A	B	C	D	E	M		
90604-WC1	4.7 (119)	13.25 (336,5)	15.75 (400,0)	10.00 (254)	6.00 (152,4)	4.00 (101,6)	6	14.94 (379,4)	14.2 (6,5)
90609-WC1	9.7 (246)	19.25 (488,9)	21.75 (552,4)	16.00 (406,4)	See Detail 1		8	20.94 (531,9)	18.2 (8,3)
90614-WC1	14.8 (375)	25.25 (641,3)	27.75 (704,8)	22.00 (558,8)	See Detail 2		10	26.94 (684,3)	21.8 (9,9)
90619-WC1	19.8 (502)	31.25 (793,7)	33.75 (857,2)	28.00 (711,2)	See Detail 3		14	32.94 (836,7)	33.2 (15,1)
90624-WC1	24.9 (632)	37.25 (946,1)	39.75 (1009,6)	34.00 (863,6)	See Detail 4		16	38.94 (989,1)	38.6 (17,5)
90629-WC1	29.9 (759)	43.25 (1098,5)	45.75 (1162,0)	40.00 (1016,0)	See Detail 5		18	44.94 (1141,5)	44.0 (20,0)
90640-WC1	40.2 (1021)	55.25 (1403,3)	57.75 (1466,8)	52.00 (1320,8)	See Detail 7		24	56.94 (1446,3)	54.9 (24,9)
90650-WC1	50.2 (1275)	67.25 (1708,1)	69.75 (1771,6)	64.00 (1625,6)	See Detail 9		28	68.94 (1751,1)	65.7 (29,8)
91204-WC1	4.7 (119)	19.25 (488,9)	21.75 (552,4)	16.00 (406,4)	See Detail 1		8	20.94 (531,9)	22.3 (10,1)
91209-WC1	9.7 (246)	25.25 (641,3)	27.75 (704,8)	22.00 (558,8)	See Detail 2		10	26.94 (684,3)	24.9 (11,3)
91214-WC1	14.8 (375)	31.25 (793,7)	33.75 (857,2)	28.00 (711,2)	See Detail 3		14	32.94 (836,7)	34.8 (15,8)
91219-WC1	19.8 (502)	37.25 (946,1)	39.75 (1009,6)	34.00 (863,6)	See Detail 4		16	38.94 (989,1)	40.2 (18,2)
91224-WC1	24.9 (632)	43.25 (1098,5)	45.75 (1162,0)	40.00 (1016,0)	See Detail 5		18	44.94 (1141,5)	45.6 (20,7)
91229-WC1	29.9 (759)	49.25 (1250,9)	51.75 (1466,8)	46.00 (1168,4)	See Detail 6		24	50.94 (1293,9)	51.0 (23,1)
91240-WC1	40.2 (1021)	61.25 (1555,7)	63.75 (1619,2)	58.00 (1473,2)	See Detail 8		28	62.94 (1598,7)	61.9 (28,1)
91250-WC1	50.2 (1275)	73.25 (1860,5)	75.75 (1924,0)	70.00 (1778,0)	See Detail 10		30	74.94 (1903,5)	72.7 (33,0)

{ 06 = Carriage length is 06 inch (152,4 mm) with 4 bearings; Carriage weight = 5.75 lbs. (2,61 kg)
} 12 = Carriage length is 12 inch (304,8 mm) with 4 bearings; Carriage weight = 8.75 lbs. (3,97 kg)

Footnotes:

(1) Weight shown is with a 0.625 inch (16 mm) diameter screw, a NEMA 23 motor mount [0.34 lbs (0,16 kg)], and a C100 style [0.09 lbs (0,04 kg)] coupling. When using a 0.750 inch (20 mm) diameter screw add 0.042 lbs per inch (0,00075 kg per mm) of screw length for a given model number. When using a 1.000 inch diameter screw add 0.117 lbs per inch (0,0021 kg per mm) of screw length for a given model number.

Dimensions

- With Waycovers -

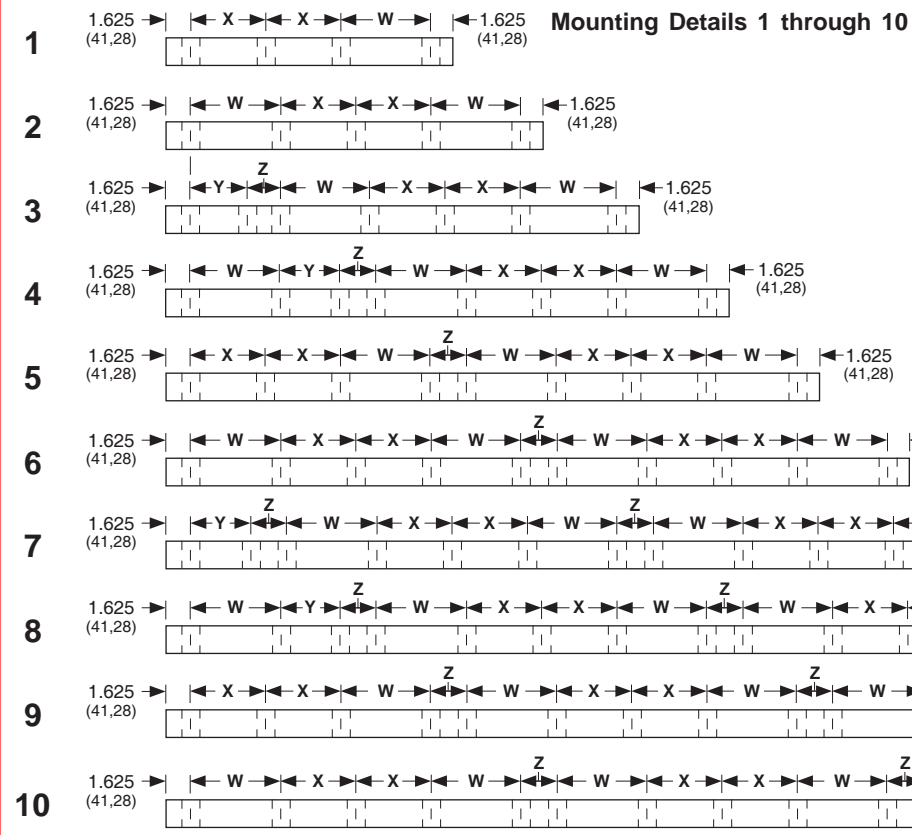
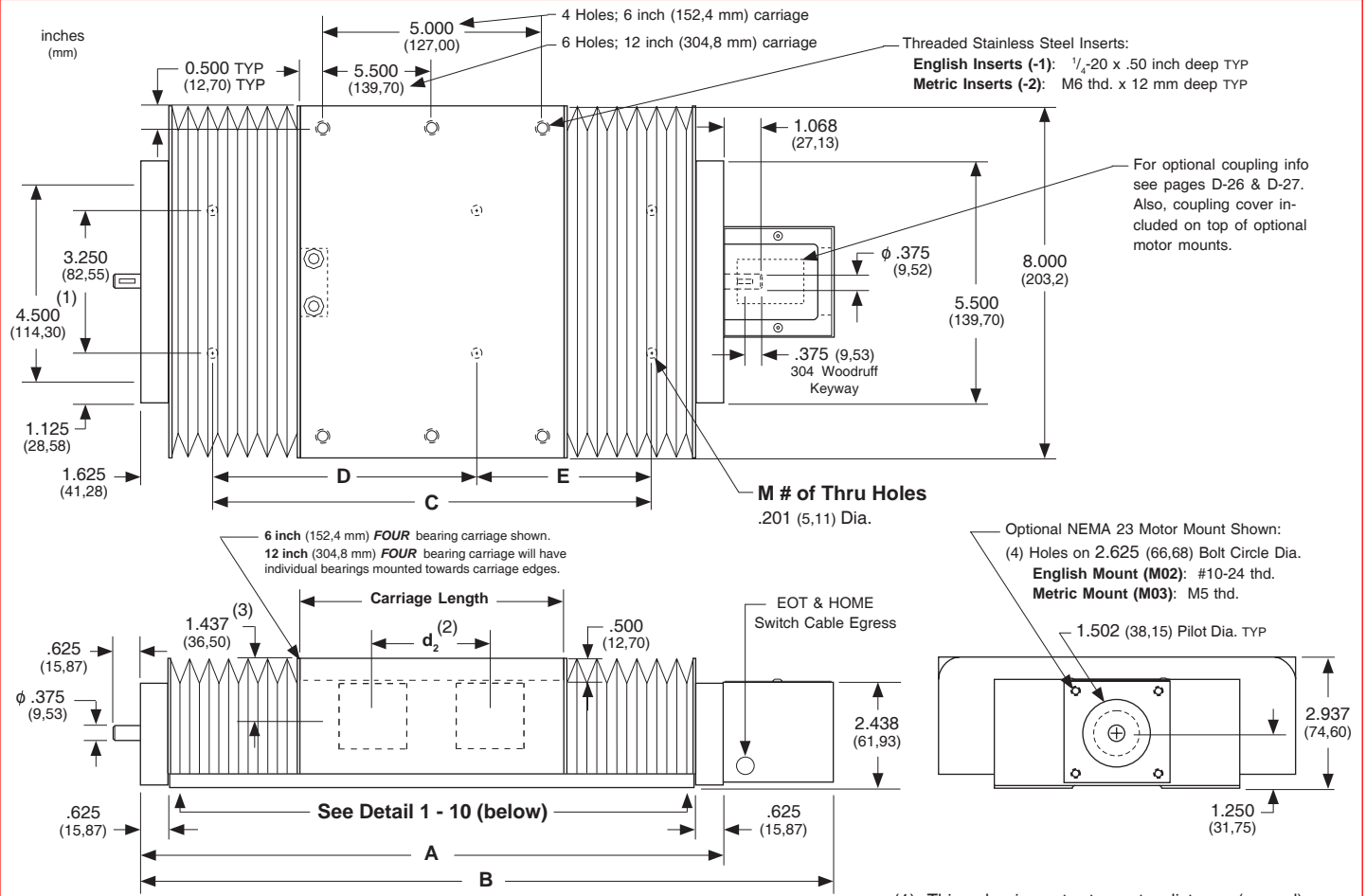

- (1) This value is center to center distance (spread) between the two rails (d_1).
 - (2) This value is center to center distance (spacing) of the bearings on a single rail (d_2) [see page D-5].
 - (3) This value is center distance of the bearing to top of carriage plate surface (d_3).
- Note:** Any 90 series table can be mounted on top of any second 90 series, in order to create X-Y multiple axis configurations. The carriage's threaded stainless steel insert hole pattern DOES NOT exactly match the base mounting hole pattern on each table, therefore machining of the bottom axis carriage plate is required. Please contact **LINTECH**.

W = 6.00 (152,4)	X = 5.00 (127,0)
Y = 4.00 (101,6)	Z = 2.00 (50,8)

Specifications subject to change without notice